

saia



The data used in this Product Overview may be used as a guideline only. Specific operational characteristics of our products may vary according to individual applications. It is strongly recommended that specific operating conditions are clarified with Johnson Electric before application.

Johnson Electric Terms and Conditions of Sale apply.

All data may be subject to change without notice.

Table of Contents

Johnson Electric Group		2
Group		
Looking for a specialized switch solution		4
Table of typical applications & Saia switch types		8
Terminology		9
Microswitches		18
Subminiature	XC, X4, V4N, V4NC	
Miniature	XG, X3, 390, 340, G3	
Table of preferred products		57

The Johnson Electric Group is one of the world's largest providers of motion actuators for automotive and industrial applications

Over the years, we have shipped billions of motors to more than thirty countries in over one hundred different motor applications. Johnson Electric has an annual production capacity of one billion motors.

to meet all of our commitments and to support our customers' success. Product reliability and assurance of supply are our commitment.

At the heart of Johnson Electric's success is our commitment to make our customers successful. Our customers include many of the world's leading industrial, consumer and automotive companies. We begin by understanding our customers' business needs, and the product application requirements of the end user of our customers' products. Then we design and deliver innovative motion solutions that help our customers to differentiate their products in the marketplace. Our goal is to be instrumental in the successful launch of our customers' products in their respective marketplaces.

Our Brand Promise

Johnson Electric is the most reliable partner

Johnson Electric is responsive and flexible; and has the financial stability and organizational integrity

Johnson Electric delivers competitive advantage

Johnson Electric delivers differentiation and innovation through its motion products – subsystems comprising of Stepper Motors, DC Motors, AC Motors, Piezo-electric Motors, Switches, Solenoids, Flexi Circuits, Motion Control, Precision Plastics and Precision Gears.

Our business growth hinges with leading "branded" goods producers to deliver differentiation and innovation through our motion products. The core platform for delivering these solutions is a highly developed production base and focused customer support teams throughout the world. This combines scale advantages in production and procurement with skilled and dedicated motion application experts.

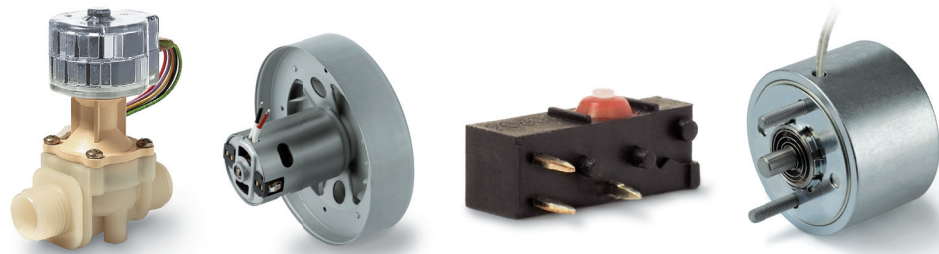

Johnson Electric Holdings Limited is the parent company of the Johnson Electric Group and has been listed on the Stock Exchange of Hong Kong since 1984. The Group structure consists of a number of operating divisions and business units focused on their particular customer application or product segment

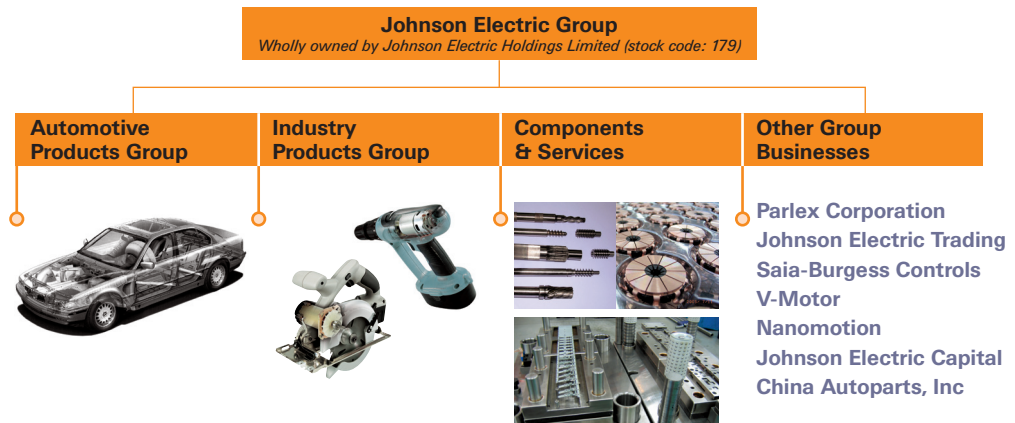

The Group's motion systems, motors and switches businesses are managed through two primary operating divisions: Automotive Products Group and Industry Products Group.

The Automotive Products Group, which consists of Johnson Electric's Automotive Motors Group and the Automotive Division of Saia-Burgess Electronics, is focused on providing customized motion solutions for major automotive application segments that include powertrain, body and chassis.

The Industry Products Group is comprised of business units that provide motion products and solutions for various commercial and industrial application sectors, including home appliances, power tools, business equipment, personal care products, medical equipment and healthcare, building automation and security, audio-visual and other industrial products.

Supporting these two operating divisions is the Group's Components & Services function which produces metal and plastic parts, tooling and production equipment for motor and motion related products. Johnson Electric is a highly vertically integrated business that manufactures an exceptionally wide range of components that form the basis for its final assembled end products. We make magnets, bearings, shafts, housings, laminations, commutators and die cast parts. We also build tools, assembly fixtures, plastic molds as well as armature winding and other production machines.

In addition to motion systems and motors, the Group also consists of a number of complementary manufacturing businesses and other subsidiary companies. These include an innovative provider of flexible printed circuits and interconnect solutions; a successful niche player in the programmable controls industry; and a rapidly growing specialty metals and trading services company.

Looking for a specialized switching solution?

Look no further.

In addition to the wide range of standard products shown in this catalog, we will be happy to working with you to meet your switching needs. If your application requires more than a standard product solution, please consider us early in your design process. Our product development team will be happy to discuss your specification, whether you need a special switch design or a complete value-added assembly. We specialize in developing switches for high-volume applications.

The images shown give some examples of our capabilities.



Saia is a leading global brand for switches for the appliances and consumer products industries

Saia defines precision switching for high volumes.

The Saia brand focuses firmly on miniature and subminiature snap-action switch types, the world's two most commonly used industry standards.

Wide range

Snap-action switches have to fulfill a wide variety of functions. Whether it is signal or power switching, high or low force actuation, there will be a Saia switch for your application – with extensive terminal and lever options to make your selection straightforward.

Environmental protection

The sealed switch is a Saia specialty. In demanding environments - wet, humid or dusty – even the most sensitive signal can be switched reliably with IP67 rated products.

Uncompromising reliability

With many UL, CSA and ENEC approvals, the performance of Saia products is globally recognized. With tens of millions of switches produced each year, this reliability is proven and established.

Precision actuation

Snap-action switches offer high levels of repeat accuracy and switch virtually independently of actuation speed and force. This is the mechanism of choice for pressure sensing, timing and position indicating applications.

Common Saia switch applications

- Washing/drying machines
- Coffee machines
- Gaming machines
- Electric showers
- Power tools and garden equipment

Switches for Locking Mechanisms

Switches are found in numerous applications that require a locking device. Whether it is a medical application, an office automation application or a door lock, switches provide an effective, cost-efficient locking mechanism.

Security Applications

- Hotel room door lock
- Hotel safe lock
- Prison door lock
- Fire safety door opening lock

Medical

- Sterilizer lock
- Centrifuge lock
- Blood analysis machine lock

Consumer

- Oven door lock for self-cleaning function
- Home safe lock

Office Automation

- Disk drive door lock
- Personal computer chassis lock
- Docking station lock
- Locks to hold peripherals in place
- Tape library index lock

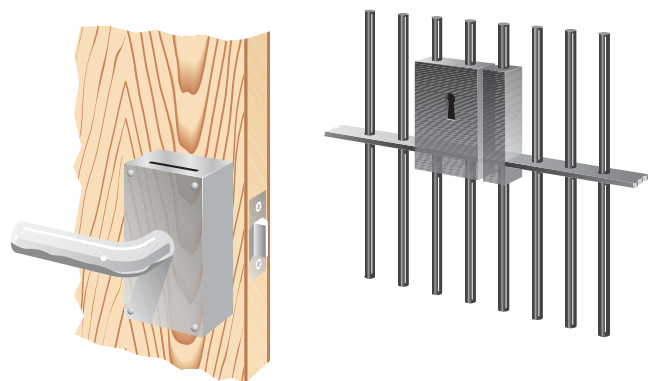

Switches in the Circuit Breaker Industry

Switches can be found in a variety of circuit breaker applications, for both domestic and commercial installations:

Domestic Circuit Breakers

- Most commonly used switches to trip breaker

Industrial Breakers

- Higher rated switches are typically used for industrial applications due to the higher switching loads

Heavy Duty Industrial Breakers

- Used in commercial and industrial applications for switching heavy loads

Molded Case Breakers

- Similar to domestic single and double pole breakers

Reclosers

- Oil or vacuum filled high voltage breakers

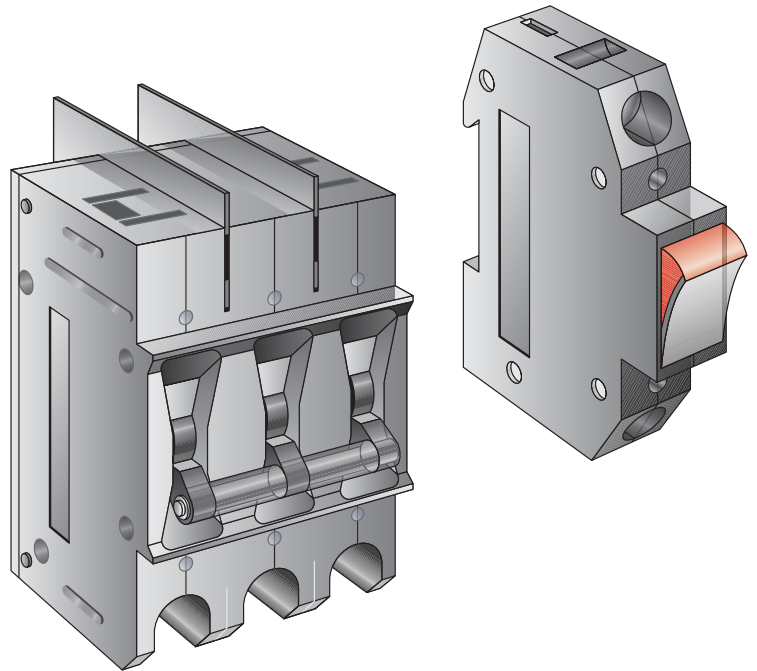

Switches for domestic appliances

Switches are found in numerous applications in the appliance industry.

Saia switches for domestic appliances

Switches used in domestic appliances have:

- a wide range of actuating force options
- reliability throughout the life of the product
- compliance with relevant UL, CSA and ENEC approvals
- the ability to switch power or signal
- environmental protection in wet or dusty applications



Saia switches for power tools and garden equipment

Switches used in power tools and garden equipment must:

- work reliably and safely, time after time
- have appropriate environmental protection to resist dust and moisture

Saia switches for vending and gaming machines

Gaming machines demand:

- dependability and reliability
- a high degree of shock resistance in the mechanism
- good tactile feel

Other application examples:

- Dispensing valves
- Beverage dispensing valves
- Product dispensers on vending machines
- Coin changers on vending machines
- Actuating devices on commercial baking and food processing or packaging equipment

Table of typical applications & Saia switch types

In addition to the products shown in the Product Catalog pages, the Product Mapping table below shows a wide range of switch types for a selection of applications. Also, a switch may be customized to fulfill your specific requirements, please feel free to contact us.

Application & Switch Series	XC	X4	V4N	V4NC	XG	X3	390	340	G3
Cash machine	●		●	●					
Circuit Breaker	●	●	●	●	●	●			
Commercial Equipment	●	●	●	●	●	●	●	●	●
Copier & Printer	●		●	●	●				
Distribution	●	●	●	●	●	●	●	●	●
Doors & gates	●		●	●	●	●	●	●	
Floor cleaning machines			●	●					
Forklifts	●		●	●	●				
Home Appliances	●	●	●	●	●	●	●	●	●
HVAC	●	●	●	●	●	●	●	●	●
Industrial automation	●		●	●	●				
Industry general	●	●	●	●	●	●	●	●	●
Medical	●		●	●	●				
Postal	●		●	●					
Power tools			●	●					●
Safety and Security	●		●	●	●				●
Specialist vehicles	●		●	●	●	●			●
Telecom	●		●	●	●				
Vending / Gaming	●	●	●	●	●	●			●
Waterheaters/Showers	●		●	●	●		●	●	
Page	18	23	28	32	37	42	47	50	54

Terminology: Snap-action switches

Contact Resistance

The contact resistance is the electrical resistance measured at the terminals of the switch when the contacts are closed. The resistance specifications refer to unwired switches in new condition.

Positions – forces – movements

Free position	Position of the actuator, without any influence from an external force.
Operating position	Position of the actuator when contact changeover takes place.
Total travel position	Position of the actuator at the end of the allowed travel.
Release position	Position of the actuator when the switch mechanism resets.
Actuating force	The force required to move the actuator from the free position to the operating position.
Release force	The value to which the applied force must be reduced to allow the mechanism to reset after operation.
Force differential	Difference between actuating force and release force.
Pre-travel	Movement of the switch actuator between free and operating position.
Over-travel	Movement of the switch actuator beyond the operating position.
Total travel	The sum of pre-travel and over-travel.
Movement differential	Distance between operating position and release position.
Release travel	Movement of the switch actuator between release and total travel position.
Post release travel	Movement of the switch actuator between release and free position.

Contact force – movement – diagram

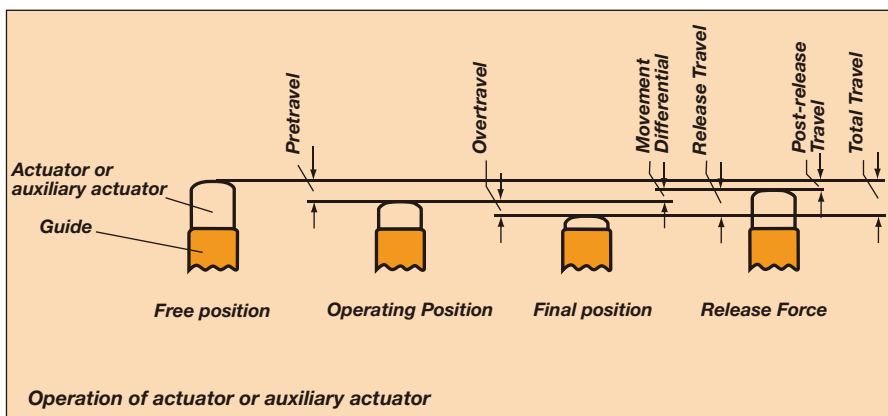

Actuating force – movement – diagram

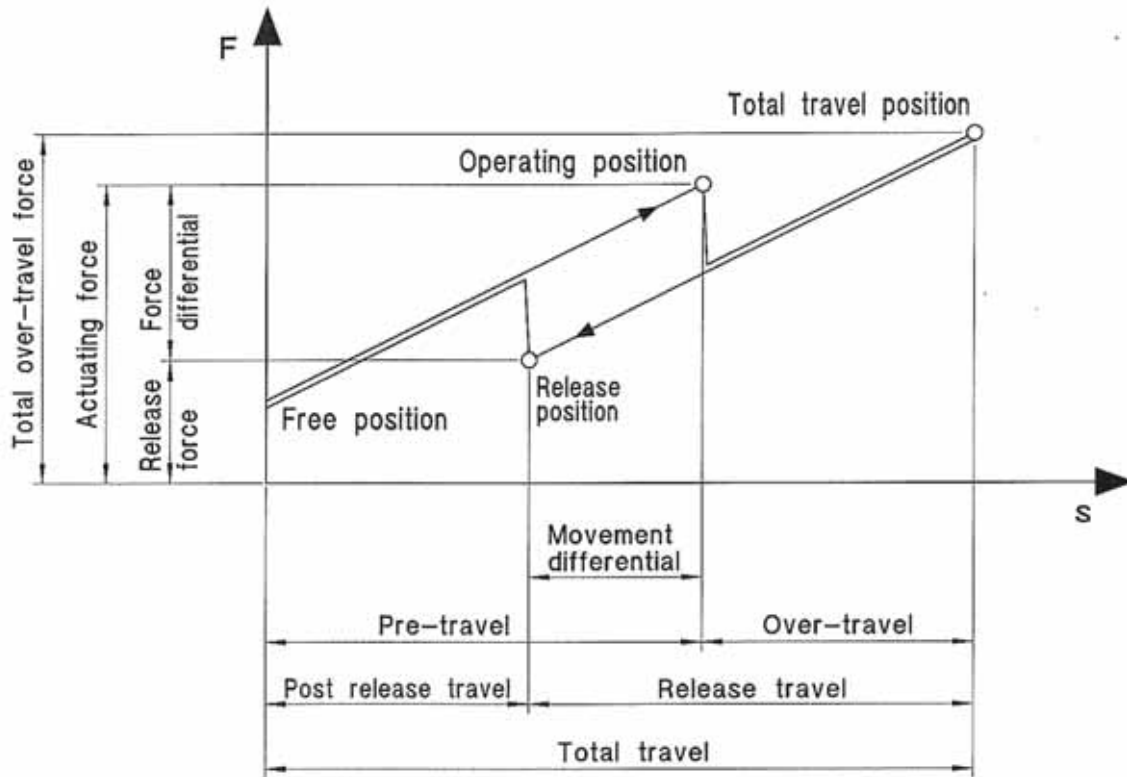

Contact force – movement – diagram

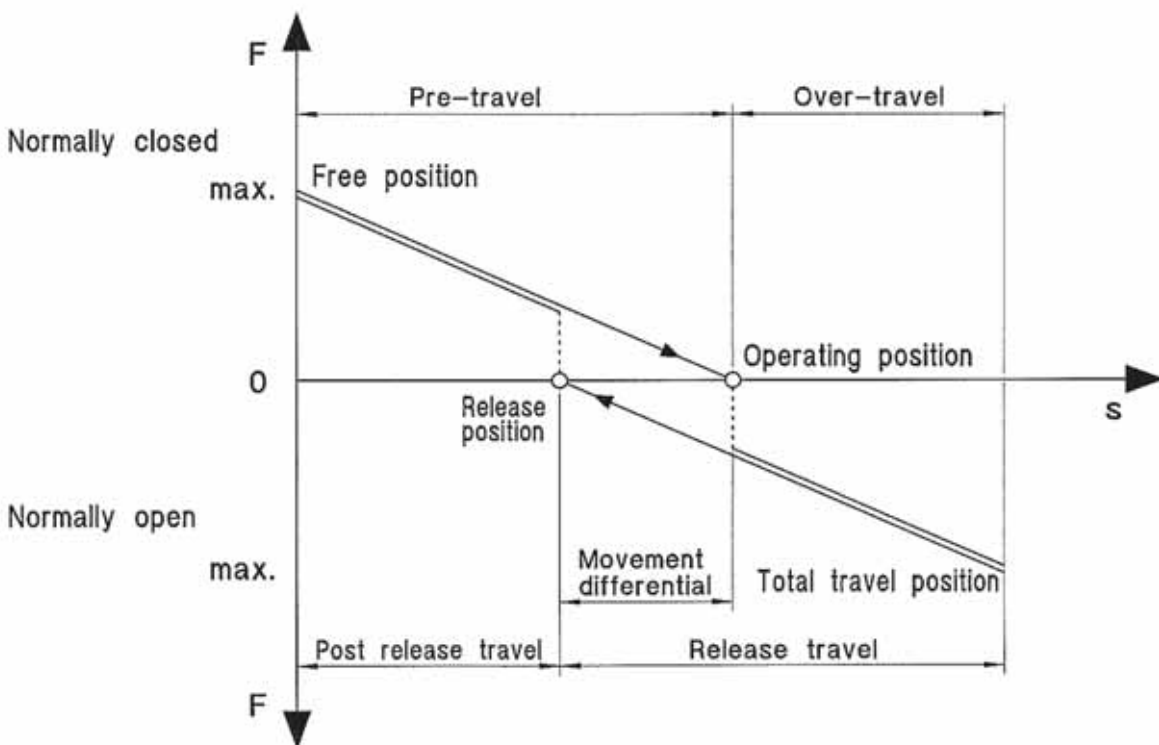

Switch Technology

Clearance Distance – the distance in air between current carrying parts of opposite polarity or between any current carrying part and an earthed-(grounded) metal plate to which the switch is attached.

Creepage Distance – the path along the surface of insulating material between current carrying parts of opposite polarity or between any current carrying part and an earthed (grounded) metal plate to which the switch is attached.

Insulation Resistance – resistance as measured between the normally closed terminals, or between all terminals connected together and a metal plate to which the switch is mounted. In dry conditions the value would be expected to be greater than 5MΩ.

Single Throw – a switch which provided an ON-OFF or OFF-ON function but does not change over from one conductor to another. Such switches are usually referred to as being «normally-closed only» or «normally-open only».

Switching Cycle – one complete switching operating from free position into overtravel and back through release position to free position.

Switch Resistance – a total resistance offered by a switch in a circuit, as measured from terminal through mating contacts, to terminal.

Transit Time – the time taken by the moving contact in a snap-action mechanism to move from one stable position to another.

Electrical Ratings

Electrical ratings given in the catalog are ratings according to UL1054, CSA22.55 or IEC61058-1.

Where these are not available, a general rating is given based upon in-house laboratory testing.

The ratings tables should be considered as safe working maximums for most applications. However, switch performance is influenced by a variety of factors, including:

- Frequency of operation
- Type of load
- Amount of travel used
- Temperature
- Humidity

Please do not hesitate to contact Saia about your specific application.

Approvals



CSA mark. Switch meets CSA's safety standards



UL Recognized Component Mark for Canada and the United States



ENEC Mark. Switch fulfills European EN standards. The two digit number indicates which certification body has issued the ENEC Certificate



CQC Approval (China) is available for certain switches

Switch Life

a. **Electrical Life** – the electrical life data contained in this catalog is based on laboratory controlled tests. In practice, frequency and speed of operation, type of load, suppression, actuator travel used, ambient humidity and temperature and other environmental conditions can have a major effect on switch life.

Individual assessments for specific applications are possible and can be undertaken by Saia on request.

Please ask Saia if you would like an assessment for your specific application.

b. **Mechanical Life** – the figures quoted relate to the number of switching cycles made without an electrical load.

Switch Drawings

All drawings in this catalog are third angle projection.

All dimensions in this catalog are nominal, except where specifically shown.

Application Technology

Shock and Vibration

If switches are likely to be subjected to shock or vibration, select models with the highest available actuating force.

Saia-switches feature low mass mechanisms which are inherently resistant to shock and vibration.

If possible, the switches should be mounted so that the line of acceleration is at right angles to the travel of the plunger. The maximum available overtravel should be used.

Direct Current

Direct current (DC) ratings where shown should not be exceeded if destructive arcing and contact welding are to be avoided.

Some form of arc suppression is recommended when switches are used in DC circuits containing inductive devices wired in series with the switch and the supply.

Lamp Loads

Because of the very high inrush currents associated with incandescent lamps, applications should be subject to individual assessment.

Capacitive Loads (including fluorescent lamps)

These can generate very high peak currents which can cause contact welding. Applications should be subject to individual assessment.

Inductive Loads

The general ratings tables included in this catalog provide data for switches used to control inductive circuits at a power factor of 0.5 (EN 0.6; UL 0,7 means HP-Rating 0,5).

Contact Materials

Silver and silver alloys are the primary contact materials used in Saia-switches.

The ratings tables shown refer to switches with silver/silver alloy contacts.

Gold contacts should be specified when switches are to be used in low voltage control or logic circuits, especially when long periods of inactivity are expected or when atmospheres with a high sulphur content may be encountered.

Gold contacts are generally available in two forms; gold plated silver alloy contacts, which can also be used at higher currents or gold alloy cross-point contacts, which are only suitable for switching low currents.

Gold-plated contacts

Gold-plated contacts (4 μm) are used for low currents of a few mA and voltages below about 20 V (for DC and AC) and for sulphurous atmospheres. They are unsuitable for higher breaking capacities.

Gold

Gold flash, a thinner deposit, is applied to certain switch terminals to ensure good solderability even after prolonged storage.

How to determine the contact material for SAIA

XG/XC-series only

The selection of the appropriate contact material will depend on a number of factors:

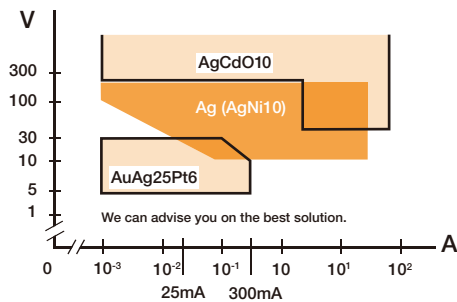

- current and voltage
- resistive or inductive load
- inrush current peak
- frequency of switching operations
- atmospheric conditions
- required switching reliability

Pure silver contacts (standard)

Saia Snap-Action Switches are normally equipped with pure silver contacts (Ag999). These are suitable for most applications and have satisfactory electrical and thermal properties.

Silver-cadmium oxide contacts

Silver-cadmium oxide (AgCdO 90/10) contacts should be used where high inrush current peaks (30 A or more) are switched on as they tend to weld less at high current loads. They can resist peaks of 80 A or more for several ms provided that they are used with a Saia Snap-Action Switch with high operating and contact force (80 cN in the free position and total-travel position).

At high breaking capacities, switches fitted with such contacts have about 50% longer life expectancy than those fitted with pure silver contacts. Normally, silver-cadmium oxide contacts are not suitable for voltages under 50 V.

Please ask Saia if you would like an assessment for your specific application.

Contact Resistance

The contact resistance is the electrical resistance measured at the terminals of the switch when the contacts are closed. The resistance specifications refer to unwired switches in new condition.

Switch Actuation

Direct Operation

Actuating plungers should be operated in the direction of their axis. Where this is not possible the use of actuating levers is recommended. For direct actuation the attack angle should not exceed 30°.

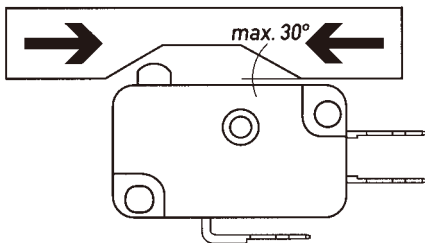

Actuation by sliding cams.

Actuating Levers

Various lever types are available for use with Saia-switches. They are generally stainless steel. If roller or cam-follower levers are approached in the reverse direction, care must be taken to ensure that the angle of approach is small enough not to jam the lever.

Actuation by Cams

Cam-follower levers are particularly well suited for use with plastic actuating cams. Abrupt actuation or release of switch actuators shortens the life of the switches. For this reason cam should preferably provide a continuous movement. Ideally they should be of cycloidal form.

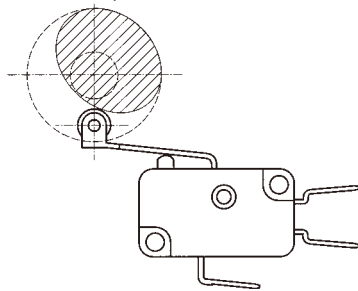

Long roller lever with continuous actuation

Environmental Protection

Protection Classifications

The protection classes of Saia switches are in accordance with IEC 529 and are covered by just four codes.

IP40

Adequate protection against solids such as probing fingers and small wires >1mm. Liquids however can gain access and, unless externally protected, the switches should be mounted in dry or well-sheltered positions.

IP54

Good protection against solid foreign bodies, including dust and water splashing against the enclosure from any direction.

Switches may be used out of doors if sheltered from the worst of the elements or on factory machines subjected to normal washing down procedures.

IP65

Complete protection against solids, including dust, and against low pressure jets of water from all directions.

IP67

Complete protection against solids including dust and against immersion in water at a specific pressure for a specified time.

We reserve this code for switches which are factory sealed and tested.

Switches should not be immersed in any liquid.

Working Temperatures

For details of the working temperatures applicable to individual types, refer to the appropriate specification sheet. Special versions suitable for temperatures outside these ranges may be possible. Please contact us for information.

All quoted temperatures assume stable operation. They do not imply an ability to withstand excessive cycling within the range.

Health & Safety

Saia has ensured, so far as it is reasonably practicable, that their products are as described in this catalog or in other current company publications, or as specified on Saia installation drawings. They have been so designed and constructed as to be safe and without risk to health when installed by

suitably qualified personnel in accordance with relevant legislation, codes of practice, regulations (including IEE Wiring Regulations), the installation recommendations offered by the company and the accepted rules of the art. Their usage should be confined within the ratings limitations and parameters of-application indicated in this catalog and elsewhere.

Please contact us should you need additional information or guidance.

Service Recommendations

Maintenance

Saia switches are not user-maintainable but they should be kept in a reasonably clean, paint-free condition, especially in the actuator area. Regular checks should be made on mounting security and on the actuating medium to switch actuator relationship.

Lubrication or the use of aqueous or chemical cleaning fluids is not recommended.

Installation Recommendations

The following notes are intended merely to stress the most important and general aspects of good switch installation procedure and to provide some helpful additional information. Safety Consideration

Installation should only be carried out by competent personnel.

Switch Positioning and Operation

Pre-loading of the switch actuator must be avoided. The actuating medium must be able to operate the switch through the operating position into overtravel and then to retract far enough to allow the switch to regain its free position.

Saia recommends that the actuating medium should drive the switch into at least 50% of the available overtravel.

All ratings tables shown in this catalog are based on the use of all the available overtravel.

Mounting

Side mounting switches should be mounted on smooth, firm, flat surfaces using the recommended screw size. Avoid over tightening the screws. For added security, they should be locked using epoxy resin. Do not attempt to enlarge switch mounting holes and avoid over stressing the switch. Use insulating material between the switch and metallic plates to increase clearance on switches with open terminals.

Connections

When soldering, overheating of the switch insulation must be avoided. In certain circumstances, it may be advisable to use a heat shunt. For optimum mechanical strength, the conductor should be wrapped round the tip of the terminal taking care to avoid loose strands of wire.

The soldering iron tip should be applied to the end of the terminal while simultaneously applying solder. Remove the iron as soon as the solder has wetted the conductor and terminal end. A-soldering iron tip temperature of 350°C (260°C/5 seconds for PCB Terminals) applied for a maximum of 2-3 seconds should be adequate.

For lead-free solder, is usually needed an iron tip temperature 15% higher.

Installation Recommendations (EN 61058-1)

Mounting Holes and Screw sizes				Mounting Screw Torque
Normal hole Diameter (mm)	(in)	Metric Thread Screw	Unified Screw	For guidance when using mild steel screws:
2.2/2.3	0.067/0.091	M2	#2	M2 or #2 screws 0.15Nm
3.1/3.2	0.122/0.126	M3	#4	M3 or #4 screws 0.5Nm
3.6/3.7	0.142/0.146	M3.5	#6	M3.5 or #6 screws 0.8Nm
5.1/5.2	0.201/0.205	M5	#10	M5 or #10 screws 3.0Nm

Snap-action Microswitches

Subminiature



Type **XC**

X4

V4N

V4NC

Characteristics

- wide range of forces and variants
- long mechanical and electrical life
- solder, PCB and faston terminals
- compliant to glow wire test IEC 60335-1, 4. ed.

- thermoplastic housing
- long mechanical and electrical life
- solder, PCB and faston terminals

- sealed (IP67)
- solder 2.8 mm faston and PCB terminals
- pre-wired option

- wide variety of levers
- peg mounting option
- pre-wired option
- sealed (IP6K7)
- solder and faston terminals
- PCB terminals

Rating

250 VAC, 10 A max.

250 VAC, 12 A max.

250 VAC, 5 A

250 VAC, 5 A

Dimensions (mm)

19.9 × 9.5 × 6.4

19.9 × 9.7 × 6.4

20 × 10.3 × 6.4

20 × 10.3 × 6.4

Actuator

- plunger
- mushroom plunger
- plain levers
- simulated roller lever/ cam follower
- roller levers

- plunger
- plain levers
- cam follower lever
- roller levers

- plunger
- plain levers
- roller levers
- simulated roller lever/ cam follower

- plunger
- plain levers
- roller levers
- simulated roller lever/ cam follower

Approvals

ENEC, UL, cUL, CSA

UL, cUL, CSA, ENEC, CQC

UL, CSA, ENEC

none

Page

18

23

28

32

Miniature



Type **XG**

X3

390

340

G3

Characteristics

- wide range of forces and ratings
- long mechanical and electrical life
- solder, faston and PCB terminals
- compliant to glow wire test IEC 60335-1, 4. ed.

- 8 mm creepage and clearance distance to the actuator
- long mechanical and electrical life
- solder, faston and PCB terminals

- wiping contacts, leaf spring mechanism
- rast 5 terminal option

- wiping contacts, leaf spring mechanism
- 3 mm contact gap option

- low operating force, high current capacity
- < 15 cN operating force option
- > 3 mm contact gap, change-over mechanism option

Rating

250 VAC, 26 A max.

250 VAC, 21 A max.

250 VAC, 25 A max.

250 VAC, 16 A max.

up to 250 VAC, 18 A

Dimensions (mm)

27.8 × 15.9 × 10.3

27.8 × 15.9 × 10.3

28.8 × 15.9 × 10.1

28.8 × 15.9 × 10.1

28 × 15.9 × 10

Actuator

- plunger
- plain levers
- roller levers
- simulated roller levers

- plunger
- straight lever
- simulated roller levers
- roller levers

- plunger
- plain levers
- roller levers
- moulded lever

- plunger
- roller lever
- plain levers
- simulated roller lever
- moulded lever

- plunger
- ramp plunger

Approvals

ENEC, UL, cUL, CSA

UL, cUL, CSA, ENEC, CQC

ENEC, UL, CSA

ENEC

ENEC, UL, CSA

Page

37

42

47

50

54

Thermoset plastic Microswitches



Circuit diagram

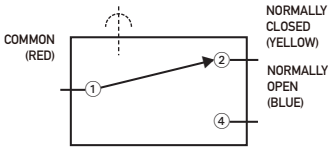

Dimension

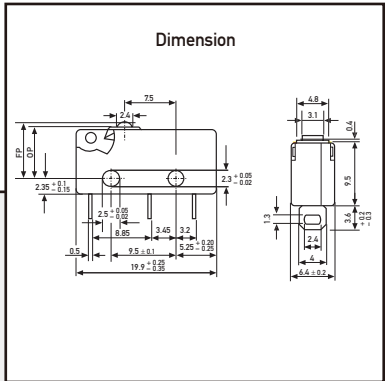

XC

- Characteristics**
- wide range of forces and variants
 - long mechanical and electrical life
 - solder, PCB and faston terminals
 - compliant to glow wire requirements as to IEC 60335-1, 4. ed.

Rating 250 VAC, 10 A max.

Dimensions (mm) 19.9 × 9.5 × 6.4

- Actuator**
- Plunger
 - mushroom plunger
 - plain levers
 - simulated roller lever/cam follower
 - roller levers

Approvals ENEC, UL, cUL, CSA



Preferred Range

Ordering Reference	Actuating Force (N)	Actuating Force (ozf)	Operating pos. (mm)	Operating pos. (in)	Terminal	Circuit	Actuator	Contacts	Electrical rating ENEC	UL/CSA
XCG3Z1	1,7	6,07	8,4	0,33	Solder	CO	Plunger	Ag	6(2) A	5 A
XCG3-J1Z1	0,6	2,14	10,2	0,40	Solder	CO	Plain lever	Ag	6(2) A	5 A
XCG3-S1Z1	0,7	2,49	15,6	0,61	Solder	CO	Roller lever	Ag	6(2) A	5 A
XCG5Z1	1,7	6,07	8,4	0,33	Faston 2.8 × 0.5 mm	CO	Plunger	Ag	6(2) A	5 A
XCG5-J1Z1	0,6	2,14	10,2	0,40	Faston 2.8 × 0.5 mm	CO	Plain lever	Ag	6(2) A	5 A
XCG5-S1Z1	0,7	2,49	15,6	0,61	Faston 2.8 × 0.5 mm	CO	Roller lever	Ag	6(2) A	5 A
XCG8-81Z1	1,7	6,07	8,4	0,33	PCB	CO	Plunger	Au	none	0,1 A / 125 VAC
XCG8-81-J1Z1	0,6	2,14	10,2	0,40	PCB	CO	Plain lever	Au	none	0,1 A / 125 VAC
XCG8-81-S1Z1	0,7	2,49	15,6	0,61	PCB	CO	Roller lever	Au	none	0,1 A / 125 VAC
XCF3Z1	3	10,70	8,4	0,33	Solder	CO	Plunger	Ag	10(3) A	10,1 A
XCF3-J1Z1	1,05	3,74	10,2	0,40	Solder	CO	Plain lever	Ag	10(3) A	10,1 A
XCF3-S1Z1	1,1	3,92	15,6	0,61	Solder	CO	Roller lever	Ag	10(3) A	10,1 A
XCG3-U1Z1	1,7	6,07	9,9	0,39	Solder	CO	Mushroom plunger	Ag	6(2) A	5 A
XCG4-U1Z1	1,7	6,07	9,9	0,39	Faston 2.8 × 0.5 mm	CO	Mushroom plunger	Ag	6(2) A	5 A
XCG8-U1Z1	1,7	6,07	9,9	0,39	PCB	CO	Mushroom plunger	Ag	6(2) A	5 A

Specifications

Housing	Melamine-Formaldehyd, Thermosetting
Plunger	POM for T85, PBT for T125, PPS for T150
Mechanism	Snap-action system with stainless steel tension spring
Functions	Change-over, NO, NC
Contacts	Fine silver (Ag) or 10 µm Gold (Au), microprofile
Terminals	Solder, faston and various PCB terminals (side of housing or side of lid, as well as 1/10" o lin pitch)
Temperature range °C	Between -40°C and +85°C (special version up to 140°C)
Mechanical life	up to 5-10 ⁷ cycles (sinusoidal actuation)
Protection	Enclosure IP40
Mounting	Side mounting through mounting holes
Actuators	Stainless steel, PA66-GF35
Contact Carrier	CuZn or CuSn

Circuit diagram

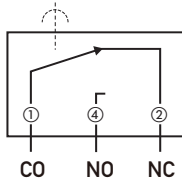

Actuating force/travel

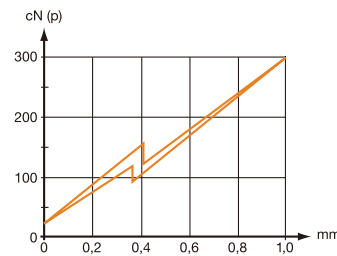

Contact force/travel

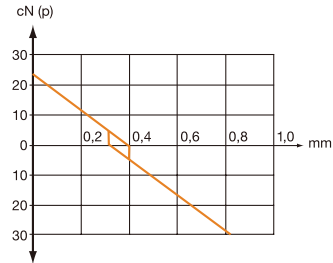

Dimensions

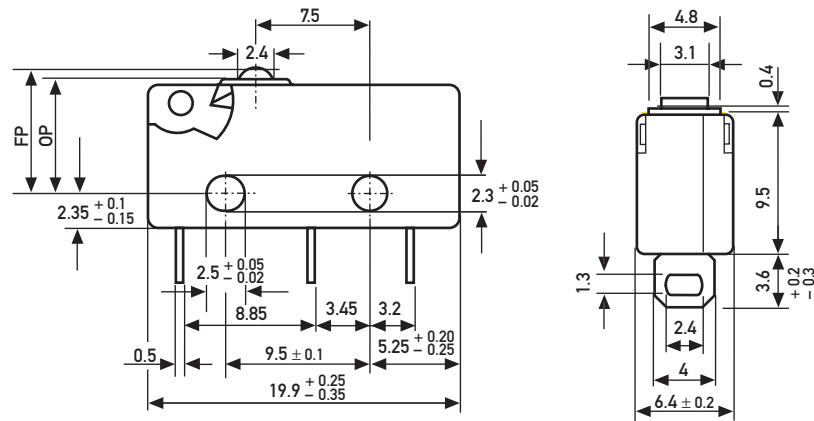

FP = Free Position
OP = Operating Position

Maximum DC rating

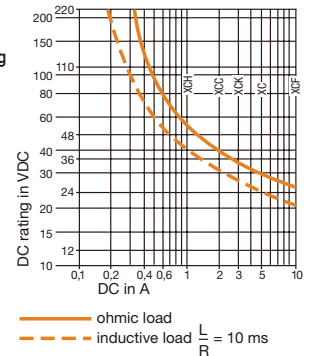

Recommended maximum electrical ratings

Voltage (VAC)	Resistive load (A)	Motor load (A)	Approvals ENEC (A)	(VAC)	Approvals UL (A)	(VAC)	Motor load
XCF 250	10	3	10 (3)	1E4	250	10,1	125/250 ½HP
XCG 250	6	2	6 (2)	5E4	250	5	-
XCK 250	5	3	5 (3)	1E4	250	5	-
XCC 250	3	1	3 (1)	5E4	250	2	-
XCH 250	1,5	0,3	1,5 (0,3)	5E4	250	1	-

Breaking capacities in the tables refer to Ag contacts.

Operating Characteristics

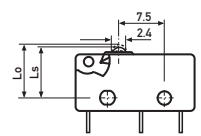
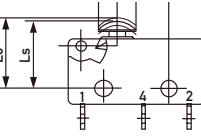
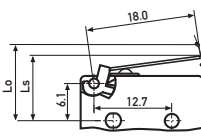
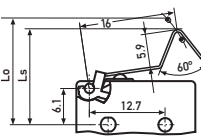
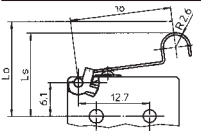
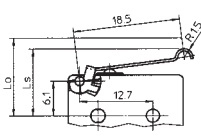
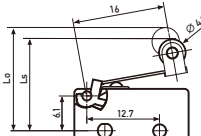
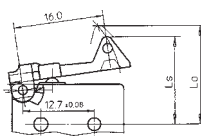
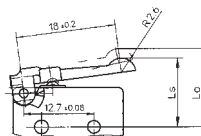
Actuator	Reference	Actuating Force		Release Force		Free Position		Operating Position		Movement Differential		Total travelled position		
		Maximum (N)	(ozf)	Minimum (N)	(ozf)	Maximum (mm)	(in)	(mm)	(in)	Maximum (mm)	(in)	Maximum (mm)	(in)	
	XCF..	3	10.70	0.5	1.78	8.8	0.34	8.4	$\left. \begin{matrix} 0.33 \\ 0.33 \\ 0.33 \\ 0.33 \end{matrix} \right\} \begin{matrix} +0.1 \\ -0.3 \end{matrix}$	$\left. \begin{matrix} 0.33 \\ 0.33 \\ 0.33 \\ 0.33 \end{matrix} \right\} \begin{matrix} +0.003 \\ -0.011 \end{matrix}$	0.1	0.003	7.7	0.303
	XCG..	1.7	6.07	0.3	1.07	8.8	0.34	8.4			0.1	0.003	7.7	0.303
	XCK..	1.2	4.28	0.2	0.71	8.8	0.34	8.4			0.1	0.003	7.7	0.303
	XCC..	0.6	2.14	0.1	0.36	8.8	0.34	8.4			0.1	0.003	7.7	0.303
	XCH..	0.35	1.24	0.07	0.24	8.8	0.34	8.4			0.1	0.003	7.7	0.303
	XCF..-U1	3	10.70	0.5	1.78	10.3	0.41	9.9	$\left. \begin{matrix} 0.39 \\ 0.39 \\ 0.39 \\ 0.39 \end{matrix} \right\} \begin{matrix} +0.1 \\ -0.3 \end{matrix}$	$\left. \begin{matrix} 0.39 \\ 0.39 \\ 0.39 \\ 0.39 \end{matrix} \right\} \begin{matrix} +0.003 \\ -0.011 \end{matrix}$	0.1	0.003	9.2	0.36
	XCG..-U1	1.7	6.07	0.3	1.07	10.3	0.41	9.9			0.1	0.003	9.2	0.36
	XCK..-U1	1.2	4.28	0.2	0.71	10.3	0.41	9.9			0.1	0.003	9.2	0.36
	XCC..-U1	0.6	2.14	0.1	0.36	10.3	0.41	9.9			0.1	0.003	9.2	0.36
	XCH..-U1	0.35	1.24	0.07	0.24	10.3	0.41	9.9			0.1	0.003	9.2	0.36
	XCF..	1.05	3.74	0.16	0.57	12.2	0.48	10.2 ± 1.0	0.401 ± 0.039	0.6	0.023	8.4	0.33	
	XCG..	0.6	2.14	0.08	0.28	12.2	0.48	10.2 ± 0.9	0.401 ± 0.035	0.5	0.019	8.5	0.337	
	XCK..	0.42	1.49	0.056	0.19	12.2	0.48	10.3 ± 0.9	0.405 ± 0.035	0.5	0.019	8.7	0.342	
	XCC..	0.22	0.78	0.025	0.08	12.2	0.48	10.3 ± 0.9	0.404 ± 0.035	0.4	0.015	8.7	0.342	
	XCH..	0.13	0.46	0.02	0.07	12.2	0.48	10.4 ± 0.9	0.409 ± 0.035	0.4	0.015	8.8	0.346	
Width of lever 4.0 mm/0.16 in														
	XCF..	1.1	3.92	0.17	0.6	17.6	0.69	15.6 ± 1.1	0.614 ± 0.043	0.6	0.023	14	0.551	
	XCG..	0.7	2.49	0.09	0.32	17.6	0.69	15.6 ± 1.0	0.614 ± 0.039	0.5	0.019	14.1	0.555	
	XCK..	0.43	1.53	0.058	0.2	17.6	0.69	15.7 ± 1.0	0.618 ± 0.039	0.4	0.015	14.3	0.562	
	XCC..	0.23	0.82	0.026	0.09	17.6	0.69	15.7 ± 1.0	0.618 ± 0.039	0.4	0.015	14.3	0.562	
	XCH..	0.14	0.49	0.021	0.07	17.6	0.69	15.8 ± 1.0	0.622 ± 0.039	0.4	0.015	14.4	0.566	
Width of lever 4.0 mm/0.16 in														
	XCF..	1.05		0.16		17.1		15.1 ± 1.1		0.6		13.3		
	XCG..	0.6		0.08		17.1		15.1 ± 1.0		0.5		13.4		
	XCK..	0.42		0.056		17.1		15.2 ± 1.0		0.5		13.6		
	XCC..	0.22		0.025		17.1		15.2 ± 1.0		0.4		13.6		
	XCH..	0.13		0.02		17.1		15.3 ± 1.0		0.4		13.7		
	XCF..	1.05		0.16		13.7		11.7 ± 1.1		0.6		9.9		
	XCG..	0.6		0.08		13.7		11.7 ± 1.0		0.5		10.0		
	XCK..	0.42		0.056		13.7		11.8 ± 1.0		0.5		10.2		
	XCC..	0.22		0.025		13.7		11.8 ± 1.0		0.4		10.2		
	XCH..	0.13		0.02		13.7		11.9 ± 1.0		0.4		10.3		
	XCF..	1.1	3.92	0.17	0.6	17.6	0.69	15.6 ± 1.2	0.614 ± 0.047	0.6	0.023	14.1	0.555	
	XCG..	0.7	2.49	0.09	0.32	17.6	0.69	15.6 ± 1.1	0.614 ± 0.043	0.5	0.019	14.2	0.559	
	XCK..	0.43	1.53	0.058	0.2	17.6	0.69	15.7 ± 1.1	0.618 ± 0.043	0.4	0.015	14.4	0.566	
	XCC..	0.23	0.82	0.026	0.09	17.6	0.69	15.7 ± 1.1	0.618 ± 0.043	0.4	0.015	14.4	0.566	
	XCH..	0.14	0.49	0.021	0.07	17.6	0.69	15.8 ± 1.1	0.622 ± 0.043	0.4	0.015	14.5	0.57	
Width of roller 4.0 mm/0.16 in. for high temperature use -T1 lever														
	XCF..	1.3	4.62	0.17	0.6	17.6	0.69	15.6 ± 1.1	0.614 ± 0.043	0.6	0.023	14	0.551	
	XCG..	0.75	2.67	0.09	0.32	17.6	0.69	15.6 ± 1.0	0.614 ± 0.039	0.5	0.019	14.1	0.555	
	XCK..	0.6	2.13	0.058	0.2	17.6	0.69	15.7 ± 1.0	0.618 ± 0.039	0.4	0.015	14.3	0.562	
	XCC..	0.31	1.10	0.026	0.09	17.6	0.69	15.7 ± 1.1	0.618 ± 0.043	0.4	0.015	14.3	0.562	
	XCH..	0.22	0.78	0.021	0.07	17.6	0.69	15.8 ± 1.0	0.622 ± 0.039	0.4	0.015	14.4	0.566	
	XCF..	1.05	3.74	0.16	0.57	14.3	0.56	12.5 ± 1.1	0.49 ± 0.043	0.6	0.023	10.6	0.417	
	XCG..	0.6	2.13	0.08	0.28	14.3	0.56	12.5 ± 1.0	0.49 ± 0.039	0.5	0.019	10.7	0.421	
	XCK..	0.42	1.49	0.056	0.21	14.3	0.56	12.6 ± 1.0	0.5 ± 0.039	0.5	0.015	10.8	0.425	
	XCC..	0.22	0.78	0.025	0.11	14.3	0.56	12.6 ± 1.0	0.5 ± 0.039	0.4	0.015	10.8	0.425	
	XCH..	0.13	0.46	0.02	0.07	14.3	0.56	12.7 ± 1.0	0.5 ± 0.039	0.4	0.015	10.9	0.429	

Ordering Reference

Basic type	XCF	3 N	10,7 ozf	Example: XCF	4	3	V	-81	-J1	Z1
	XCG	1,7 N	6,07 ozf							
	XCK	1,2 N	4,28 ozf							
	XCC	0,6 N	2,14 ozf							
	XCH	0,35 N	1,24 ozf							
Circuits		No symbol, change-over								
	4	Normally closed (NC)								
	5	Normally open (NO)								
Terminals	3	Solder								
	4	plug 2.8 × 0.5 mm DIN								
	5	plug 2.8 × 0.5 mm AMP								
	8	PCB, L = 4,5 mm								
	9	PCB, 1/10" pitch, L = 4,5 mm								
	10	PCB, formed to base								
	11	PCB, formed to lid								
	12	PCB, formed to base, 1/10" pitch								
	13	PCB, formed to lid, 1/10" pitch								
	14	PCB, L = 3,5 mm								
	15	PCB, 1/10" pitch, L = 3,5 mm								
Version		No symbol, Housing material MF, Europe up to 85°C, UL up to 90°C								
	V	(High temperature 125°C), Housing material MF / Plunger PBT, Europe up to 125°C, UL up to 130°C								
	W	(High temperature 140°C), Housing material MF / Plunger PPS, Europe up to 140°C, UL up to 150°C								
Contacts		No symbol, Ag (Ag)								
	-81	μ profile Au 10 μm								
Actuators		No symbol, plunger								
	-J1	Plain lever 18,0 mm (0.71 in)								
	-J2	Plain lever 25,0 mm (0.98 in)								
	-J5	Plain lever 40,0 mm (1.57 in)								
	-S1	Roller lever 16,0 mm (0.63 in)								
	-L1	Cam follower 16,0 mm (0.63 in)								
	-L6	Cam follower 18,0 mm (0.71 in)								
	-L9	Cam follower 18,5 mm (0.73 in)								
	-P5	Plastic lever 16,0 mm (0.63 in)								
	-P6	Plastic lever 18,0 mm (0.71 in)								
	-U1	Mushroom plunger								
		Other actuators on special request.								
Approvals		No symbol, ENEC								
	Z1	UL, CSA								

Thermoplastic Microswitches



Circuit diagram

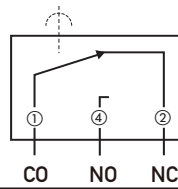

Dimension

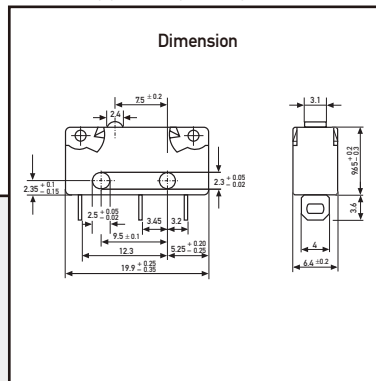

X4

- Characteristics
- thermoplastic housing
 - long mechanical and electrical life
 - solder, PCB and faston terminals

Rating 250 VAC, 12 A max.

Dimensions (mm) 19.9 × 9.7 × 6.4

- Actuator
- plunger
 - plain levers
 - cam follower lever
 - roller levers

Approvals UL, cUL, CSA, ENEC, CQC



Preferred Range

Ordering Reference	Actuating Force		Operating pos. (mm)	Terminal	Circuit	Actuator	Contacts	Electrical rating	
	(N)	(ozf)						ENEC	UL/CSA
X4F303K1AA	3.3	11.869	8.4	Solder	CO	Plunger	Ag	12 (6) A	12 A
X4F305K1AA	3.3	11.869	8.4	Faston	CO	Plunger	Ag	12 (6) A	12 A
X4G303K1BB	2	7.193	8.4	Solder	CO	Plunger	Ag	6 (3) A	6 A
X4G305K1BB	2	7.193	8.4	Faston	CO	Plunger	Ag	6 (3) A	6 A
X4C303K1CC	0.75	2.697	8.4	Solder	CO	Plunger	Ag	3 (2) A	3 A
X4C305K1CC	0.75	2.697	8.4	Faston	CO	Plunger	Ag	3 (2) A	3 A

Specifications

Housing	Thermoplastic
Plunger	Thermoplastic
Mechanism	Snap-action system with stainless steel tension spring
Functions	Change-over, NO, NC,
Contacts	Fine silver (Ag), or 10 µm Gold (Au), microprofile
Terminals	Solder, faston, PCB, side-facing PCB and 'PCB terminals with 0.1" pitch
Temperature range °C	Between -40°C and +85°C
Mechanical life	10 ⁶ cycles minimum
Protection	Enclosure – IP 40
Mounting	Side mounting or PCB
Actuators	Stainless steel, PA66–GF35
Contact carrier	CuZn or CuSn

Circuit diagram

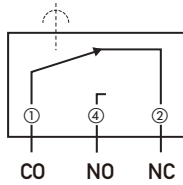

Actuating force/travel

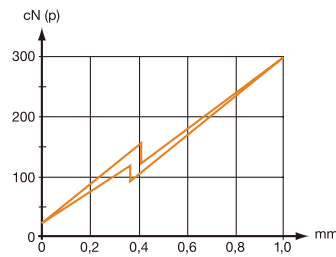

Contact force/travel

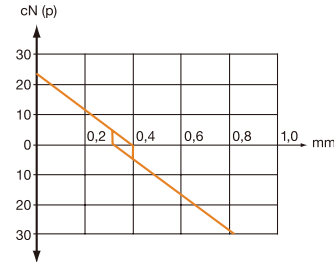

Dimensions

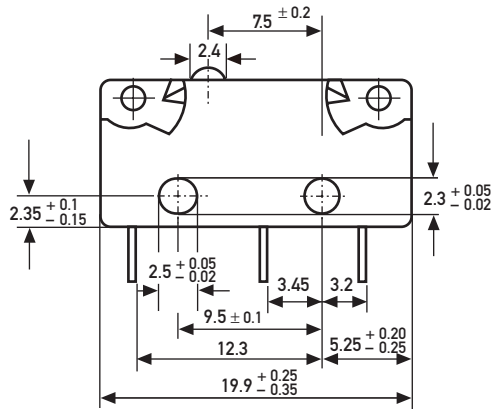

Maximum DC rating

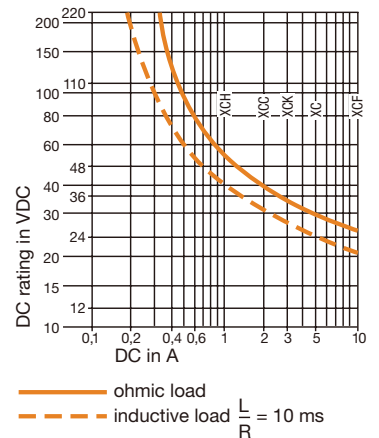

Recommended maximum electrical ratings

	Voltage (VAC)	Resistive load (A)	Motor load (A)	Approvals ENEC (A)		(VAC)	Approvals UL (A)	(VAC)
X4F	250	12	6	12 (6)	1E4	250	12	125/250
X4G	250	6	3	6 (3)	5E4	250	6	125/250
X4C	250	3	2	3 (2)	5E4	250	3	125/250

Breaking capacities in the tables refer to silver contacts

Operating Characteristics

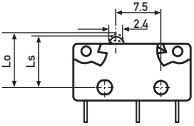
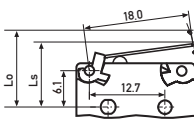
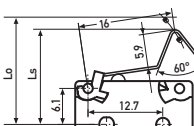
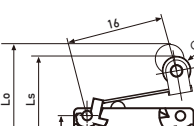
Actuator	Reference	Actuating Force		Release Force		Free Position		Operating Position		Movement Differential		Full Overtravel Position		
		Maximum (N)	(ozf)	Minimum (N)	(ozf)	Maximum (mm)	(in)	Maximum (mm)	(in)	Maximum (mm)	(in)	Maximum (mm)	(in)	
	X4F	3.3	11,869	0.55	1,978	8,8	0,35	8,4	$\left. \begin{array}{l} +0,1 \\ -0,3 \end{array} \right\} 0,33$	$\left. \begin{array}{l} +0,004 \\ -0,01 \end{array} \right\} 0,33$	0,2	0,008	7,7	0,3
	X4G	2.0	7,193	0,35	1,258	8,8	0,35	8,4						
	X4C	0,75	2,697	0,13	0,467	8,8	0,35	8,4						
	X4F	1,16	4,172	0,18	0,647	12,2	0,48	10,2 ±1,0	0,4 ±0,035	0,6	0,024	8,4	0,33	
	X4G	0,7	2,517	0,094	0,338	12,2	0,48	10,2 ±0,9	0,4 ±0,039	0,5	0,02	8,5	0,33	
	X4C	0,28	1,007	0,031	0,107	12,2	0,48	10,3 ±0,9	0,4 ±0,039	0,4	0,016	8,7	0,34	
Width of lever 4.0 mm/0.16 in														
	X4F	1,21	4,352	0,19	0,683	17,6	0,69	15,6 ±1,1	0,61 ±0,043	0,6	0,024	14	0,55	
	X4G	0,82	2,949	0,11	0,395	17,6	0,69	15,6 ±1,0	0,61 ±0,039	0,5	0,02	14,1	0,56	
	X4C	0,29	1,043	0,033	0,118	17,6	0,69	15,7 ±1,0	0,61 ±0,039	0,4	0,016	14,3	0,56	
Width of lever 4.0 mm/0.16 in														
	X4F	1,21	4,352	0,19	0,683	17,6	0,69	15,6 ±1,2	0,61 ±0,047	0,6	0,024	14,1	0,56	
	X4G	0,82	2,949	0,11	0,395	17,6	0,69	15,6 ±1,1	0,61 ±0,043	0,5	0,02	14,2	0,56	
	X4C	0,29	1,043	0,036	0,129	17,6	0,69	15,7 ±1,1	0,62 ±0,043	0,4	0,016	14,4	0,57	
Width of roller 4.0 mm/0.16 in														

Ordering Reference

Basic type	X4	Example: X4	F	3	03	K	1	A	A	J1	1																			
Operating force	F	extra high force	G	high force	C	low force																								
Circuits diagram	3	Change-over (CO)	4	Normally closed (NC)	5	Normally open (NO)	} with X4F and X4G not possible (except gold contacts)																							
Terminals	03	Solder terminal	04	Faston terminal 2.8 × 0.5 mm DIN	05	Faston terminal 2.8 × 0.5 mm	08	PCB-terminal, length 4.5 mm	09	PCB-terminal, length 4.5 mm, (pitch 7.6)	10	PCB-terminal, formed to base	11	PCB-terminal, formed to lid	12	PCB-terminal, formed to base, (pitch 7.6)	13	PCB-terminal, formed to lid, (pitch 7.6)	14	PCB-terminal, length 3.5 mm	15	PCB-terminal, length 3.5 mm, (pitch 7.6)	21	Equidistant PCB-terminals, length 8.15 mm (pitch 7.5)	22	Equidistant PCB-terminals formed to base (pitch 7.5)	23	Equidistant PCB-terminals formed to lid (pitch 7.5)	24	Equidistant faston terminals 2.8 × 0.5 mm DIN (pitch 7.5)
Body	K	Ultradid, for terminal types 03 to 15 only	N	Latamid, compliant to glow wire requirements as to IEC 60335-1, 4. ed., for terminal types 03 to 15 only	M	Ultradid, for equidistant terminal types 21 to 24 only	R	Ultradid, with moulded pegs, for equidistant terminal types 22 and 23 only																						
Contacts material	1	Silver/Silver	8	Gold microprofile (Crosspoint) contacts	9	Gold-plated																								
UL/C-UL ratings	A	12 A, 125/250 VAC	B	6 A, 125/250 VAC	C	3 A, 125/250 VAC	D	0.1 A, 125 VAC	N	no approvals																				
EN/IEC ratings	A	12 (6) A, 250 V~ 1E4 T85 μ approved	B	6 (3) A, 250 V~ 5E4 T85 μ approved	C	3 (2) A, 250 V~ 5E4 T85 μ approved	F	10 (4) A, 250 V~ 1E4 T125 μ approved	L	1 A, 30 V = not approved	M	0.3 A, 30 V~ 1E4 not approved																		
Type of actuators	J1	No symbol, without lever	L1	Plain lever	S1	18.0 mm (0.71 in)	L1	Cam follower	S1	16.0 mm (0.63 in)	S1	Roller lever	S1	16.0 mm (0.63 in)																
Other actuators on special request																														
Actuator position	1	No symbol, without lever	1	Lever above terminal 1	2	Lever above terminal 2																								

Sealed and unsealed Microswitches

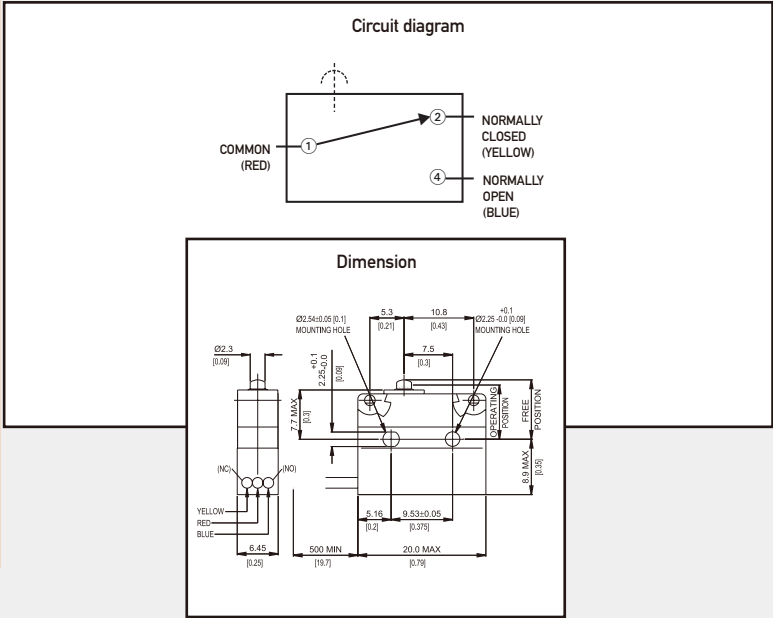

V4N

Characteristics ■ sealed (IP67)
 ■ solder, 2.8 mm faston and PCB terminals
 ■ pre-wired option

Rating 250 VAC, 5 A

Dimensions (mm) 20 × 10.3 × 6.4

Actuator ■ plunger
 ■ plain levers
 ■ roller levers
 ■ simulated roller lever/cam follower

Approvals UL, CSA, ENEC



Preferred Range

Ordering Reference	Actuating Force (N) (ozf)		Sealing	Operating pos. (mm) (in)		Terminal	Circuit	Actuator	Contacts	Electrical rating
V4NT7UL	1,40	5,0	IP40	8,40	0,33	Solder	CO	Plain plunger	Ag	250 VAC, 5 A
V4NST7UL	2,50	9,0	IP67	8,40	0,33	Solder	CO	Plain plunger	Ag	250 VAC, 5 A
V4NSUL	2,50	9,0	IP67	8,40	0,33	Pre-wired	CO	Plain plunger	Ag	250 VAC, 5 A
V4NT7Y1UL	0,50	1,8	IP40	10,7	0,42	Solder	CO	Straight lever	Ag	250 VAC, 5 A
V4NST7Y1UL	0,90	3,2	IP67	10,6	0,42	Solder	CO	Straight lever	Ag	250 VAC, 5 A
V4NSY1UL	0,90	3,2	IP67	10,6	0,42	Pre-wired	CO	Straight lever	Ag	250 VAC, 5 A
V4NT7YRUL	0,50	1,8	IP40	15,7	0,62	Solder	CO	Roller lever	Ag	250 VAC, 5 A
V4NST7YRUL	0,90	3,2	IP67	15,6	0,62	Solder	CO	Roller lever	Ag	250 VAC, 5 A
V4NSYRUL	0,90	3,2	IP67	15,6	0,62	Pre-wired	CO	Roller lever	Ag	250 VAC, 5 A

Specifications

Housing	Flame-retardant glass-fibre reinforced nylon
Plunger	Polyacetal (POM)
Mechanism	Snap-action coil spring mechanism with stainless steel spring
Functions	Change-over, normally closed or normally open
Contacts	Silver
Terminals	Gold flashed
Temperature range °C	-40°C to +85°C
Mechanical life	5 × 10 ⁶ cycles minimum (impact free actuation) for the cowl 3 × 10 ⁶
Protection	IP40 (V4N - enclosure), IP67 (V4NS - enclosure)
Mounting	Side mounting
Actuators	Plain lever, cam follower, Roller lever
Accessories	Insulating sheet - N04619. Clip-on terminal cover - TC102. Long overtravel actuator - QA4

Circuit diagram

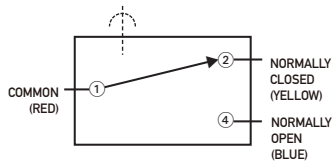

Dimensions

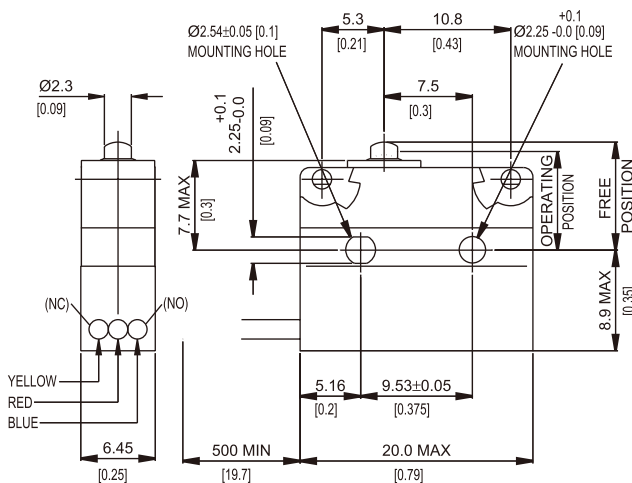

Recommended maximum electrical ratings

	Voltage (max)	Load (A)	Inductive load (A)	Approval
V4NT7UL/ V4NST7UL	250 VAC	5 (0.75 pf)		UL 1054/CSA 22.2 No. 55 - 6,000 operations - 65°C EN61058-1, T85, 10,000 operations
	250 VAC	5	2	
	0 - 15 VDC	5	3	General rating - 50,000 operations (85°C)
	15 - 30 VDC	5	3	General rating - 50,000 operations (85°C)
V4NSUL	250 VAC	3 (0.75 pf)		UL 1054/CSA 22.2 No. 55 - 6,000 operations - 65°C EN61058-1, T85, 10,000 operations
	250 VAC	5	2	
	0 - 15 VDC	3	3	General rating - 50,000 operations (85°C)
	15 - 30 VDC	3	3	General rating - 50,000 operations (85°C)

Operating Characteristics

Actuator	Reference	Actuating Force		Release Force		Free Position		Operating Position		Movement Differential	
		Maximum (N)	(ozf)	Minimum (N)	(ozf)	Maximum (mm)	(in)	(mm)	(in)	Maximum (mm)	(in)
Plunger 	V4NT7UL	1.4	5.00	0.28	1.00	9.2	0.36	8.4 ± 0.3	0.33 ± 0.012	0.1	0.004
	V4NST7UL	2.5	9.00	0.30	1.00	9.2	0.36	8.4 ± 0.3	0.33 ± 0.012	0.1	0.004
	V4NSUL	2.5	9.00	0.3	1.00	9.2	0.36	8.4 ± 0.3	0.33 ± 0.012	0.1	0.004
Y1 lever 	V4NT7Y1UL	0.5	1.80	0.07	0.25	13.2	0.52	10.7 ± 1.0	0.42 ± 0.04	0.4	0.016
	V4NST7Y1UL	0.9	3.20	0.07	0.25	13.2	0.52	10.6 ± 1.2	0.42 ± 0.05	0.4	0.016
	V4NSY1UL	0.9	3.20	0.07	0.25	13.2	0.52	10.6 ± 1.2	0.42 ± 0.05	0.4	0.016
Width of lever 4.0 mm/0.16 in											
YC lever 	V4NT7YCUL	0.5	1.80	0.07	0.25	17.8	0.70	15.7 ± 1.0	0.62 ± 0.04	0.4	0.016
	V4NST7YCUL	0.9	3.20	0.07	0.25	17.8	0.70	15.6 ± 1.2	0.61 ± 0.05	0.4	0.016
	V4NSYCUL	0.9	3.20	0.07	0.25	17.8	0.70	15.6 ± 1.2	0.61 ± 0.05	0.4	0.016
Width of lever 4.0 mm/0.16 in											
YR lever 	V4NT7YRUL	0.5	1.80	0.07	0.25	17.8	0.70	15.7 ± 1.0	0.62 ± 0.04	0.4	0.016
	V4NST7YRUL	0.9	3.20	0.07	0.25	17.8	0.70	15.6 ± 1.2	0.61 ± 0.05	0.4	0.016
	V4NSYRUL	0.9	3.20	0.07	0.25	17.8	0.70	15.6 ± 1.2	0.61 ± 0.05	0.4	0.016
Width of lever 4.0 mm/0.16 in											

Over travel: Plunger can be depressed flush with housing. The housing should not be used as an end stop.

Ordering Reference

Basic type	V4N	Example: V4N	E	T6	C2	Y1	0	G	UL
Type of sealing/ Overtravel	No symbol, unsealed, standard travel								
	E	Unsealed with extended overtravel (0.5 mm)							
	S	Sealed IP67 standard travel							
	B	Sealed IP67 with extended overtravel (0.5 mm)							
Terminals	No symbol, pre-wired 500 mm with cable box K2 (V4NS/B only)								
	T6	Faston 2.03 × 0.5 × 6.6 long							
	T7	Solder 2.95 × 0.5 × 3.6 long							
	T8	PCB 0.8 × 0.5 × 4.0 long							
	T9	Faston 2.8 × 0.5 × 8.1 long							
	T81	Formed PCB 0.8 × 0.5 × 3.8 long							
	T82	Formed PCB 0.8 × 0.5 × 3.8 long							
	T83	Formed PCB 8.8 × 0.5 × Surface mount							
	T84	Short PCB 0.8 × 0.5 × 2.0 long							
	T85	Long PCB 0.8 × 0.5 × 6.85 long							
	T86	PCB 0.8 × 0.5 × 4.0 long (equi-spaced)							
	T11	Solder 2.95 × 0.5 × 3.6 long							
Circuit	No symbol, change-over								
	C2	Normally closed							
	C4	Normally open							
Actuators	No symbol, without lever								
	Y1	Plain lever 18.0 mm							
	Y2	Plain lever 25.0 mm							
	Y3	Plain lever 32.0 mm							
	YC	Cam follower lever 18.5 mm							
	YR	Roller lever 16.0 mm							
	PB	Push Button (see specification PBA4/QA4)							
	QA	Push Button (see specification PBA4/QA4)							
	Other actuators on special request								
Actuator Position	No symbol, without lever, or lever fitted at the end nearest to the Plunger								
	0	With lever fitted at end opposite to plunger							
Contact Material	No symbol, Fine silver								
	G	Gold plate on silver							
	X	Gold alloy on silver palladium crosspoint							
Approvals	No symbol, without approval								
	UL	UL, CSA and ENEC approval							
Special Features	/ <input type="checkbox"/> <input type="checkbox"/> <input type="checkbox"/> <input type="checkbox"/> Saia specialise in customer specific solutions. Additional product variants are available or can be provided. If your requirements cannot be satisfied from the options listed, please contact www.saia-burgess.com or your local SB outlet.								

V4NC

- Characteristics
- wide variety of levers
 - peg mounting option
 - pre-wired option
 - sealed (IP6K7)
 - solder and faston terminals
 - PCB terminals

Rating 250 VAC, 5 A

Dimensions (mm) 20 × 10.3 × 6.4

- Actuator
- plunger
 - plain levers
 - roller levers
 - simulated roller levers

Approvals none



Preferred Range

Ordering Reference	Actuating Force (N)	Actuating Force (ozf)	Sealing	Operating pos. (mm) (in)		Terminal	Circuit	Actuator	Contacts	Electrical rating
V4NCT7	1.7	6.114	No symbol	8.40	0.331	Solder	CO	Plunger	Ag	250 VAC, 5 A
V4NCT7A1	0.8	2.877	No symbol	10.85	0.427	Solder	CO	Plain lever	Ag	250 VAC, 5 A
V4NCT7AR	0.8	2.877	No symbol	16.00	0.630	Solder	CO	Roller lever	Ag	250 VAC, 5 A
V4NCS	2.5	8.992	Sealed IP6K7	8.40	0.331	Cable 500 mm	CO	Plunger	Ag	250 VAC, 5 A
V4NCSA1	0.9	3.237	Sealed IP6K7	10.80	0.425	Cable 500 mm	CO	Plain lever	Ag	250 VAC, 5 A
V4NCSAR	0.9	3.237	Sealed IP6K7	15.90	0.626	Cable 500 mm	CO	Roller lever	Ag	250 VAC, 5 A

Specifications

Housing	Glass fibre reinforced Polyamide (PA 6.6)
Plunger	Polyacetal POM/(PA 4.6)
Mechanism	Snap-action coil spring mechanism with stainless steel spring
Functions	Change-over, normally closed or normally open
Contacts	Fine Silver, Gold plate on silver, Gold alloy on silver palladium (crosspoint)
Terminals	Gold flashed
Temperature range °C	-40°C to +85°C/120°C
Mechanical life	5 × 10 ⁶ cycles minimum (impact free actuation) for the cowl 3 × 10 ⁶
Protection	IP40, IP6K7 (depend on type), Flux-proof terminal entries (for all types)
Mounting	Side mounting (moulded mounting pegs on request)
Actuators	Plain lever, cam follower, roller lever, simulated roller (cam follower) lever
Accessories	Lug mounting frame, clip-on terminals cover, insulating sheet

Circuit diagram

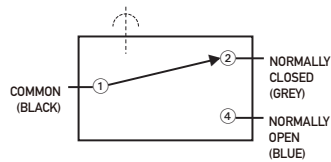

Dimensions

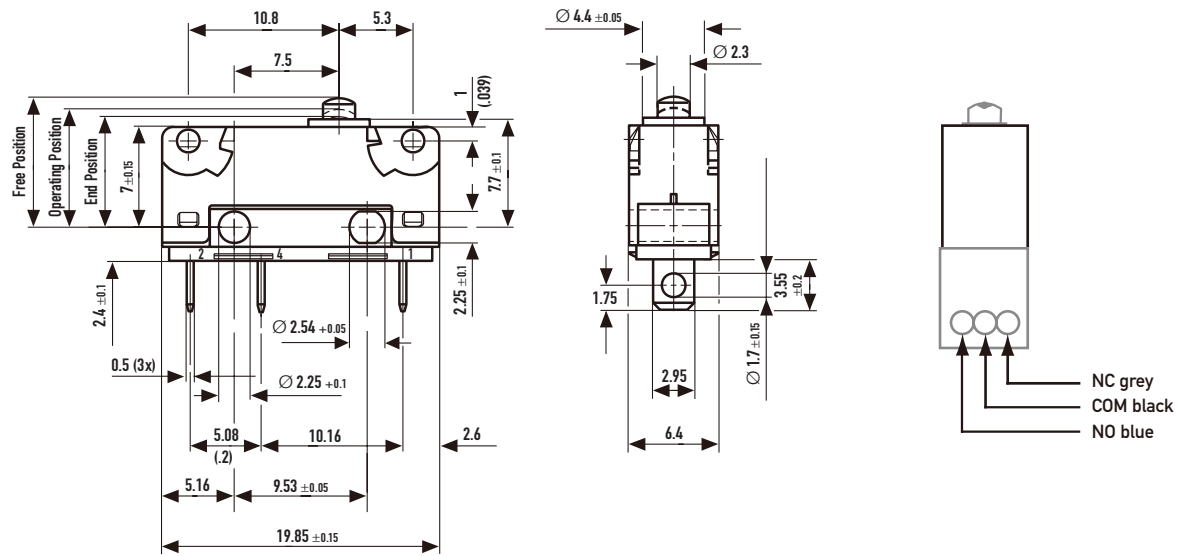

Prewired version with cable box

For type coding key please contact Saia

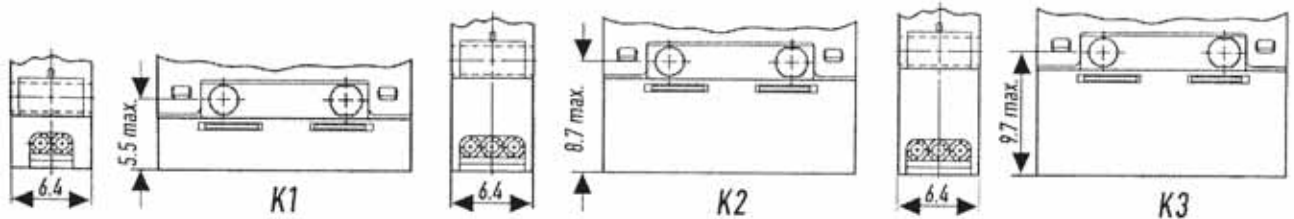

Standard cable FLRY 0.5 mm² with max. outside diameter 1.8 mm
Standard cable box is K2

Operating Characteristics

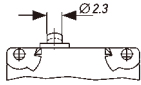
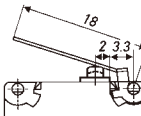
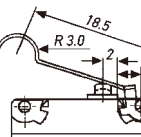
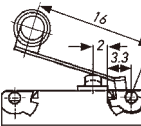
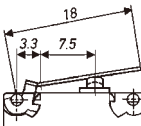
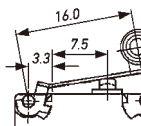
Actuator	Reference	Actuating Force		Release Force		Free Position		Operating Position		Movement Differential	
		Maximum (N)	(ozf)	Minimum (N)	(ozf)	Maximum (mm)	(in)	(mm)	(in)	Maximum (mm)	(in)
	V4NC..	1.7	6,114	0.3	1,079	9.2	0,362	8,4 ± 0.3	0,331 ± 0.012	0.1	0,004
	V4NCE..	1.7	6,114	0.3	1,079	9.7	0,382	8,9 ± 0.3	0,35 ± 0.012	0.1	0,004
	V4NCS..	2.5	8,992	0.5	1,798	9.2	0,362	8,4 ± 0.3	0,331 ± 0.012	0.1	0,004
	V4NCSE..	2.5	8,992	0.5	1,798	9.7	0,382	8,9 ± 0.3	0,35 ± 0.012	0.1	0,004
	V4NC..	0.8	2,877	0.07	0,251	13.4	0,527	10,85 ± 1.3	0,427 ± 0.051	0.4	0,016
	V4NCE..	0.8	2,877	0.07	0,251	14.8	0,582	12,4 ± 1.3	0,488 ± 0.051	0.4	0,016
	V4NCS..	0.9	3,237	0.1	0,359	13.4	0,527	10,8 ± 1.3	0,425 ± 0.051	0.4	0,016
	V4NCSE..	0.9	3,237	0.1	0,359	14.8	0,582	12,4 ± 1.3	0,488 ± 0.051	0.4	0,016
Width of lever 4.0mm/0.16 in											
	V4NC..	0.8	2,877	0.07	0,251	16.1	0,634	13,5 ± 1.3	0,531 ± 0.051	0.4	0,016
	V4NCE..	0.8	2,877	0.07	0,251	17.6	0,693	15,1 ± 1.3	0,594 ± 0.051	0.4	0,016
	V4NCS..	0.9	3,237	0.1	0,359	16.1	0,634	13,4 ± 1.3	0,527 ± 0.051	0.4	0,016
	V4NCSE..	0.9	3,237	0.1	0,359	17.6	0,693	15,1 ± 1.3	0,594 ± 0.051	0.4	0,016
Width of lever 4.0mm/0.16 in											
	V4NC..	0.8	2,877	0.07	0,251	18.1	0,712	16 ± 1.2	0,63 ± 0.047	0.4	0,016
	V4NCE..	0.8	2,877	0.07	0,251	19.2	0,756	17,3 ± 1.2	0,681 ± 0.047	0.4	0,016
	V4NCS..	0.9	3,237	0.1	0,359	18.1	0,712	15,9 ± 1.2	0,626 ± 0.047	0.4	0,016
	V4NCSE..	0.9	3,237	0.1	0,359	19.2	0,756	17,3 ± 1.2	0,681 ± 0.047	0.4	0,016
Width of lever 4.0mm/0.16 in											
	V4NC..	1.3	4,676	0.13	0,467	10.7	0,421	9,4 ± 0.7	0,37 ± 0.027	0.2	0,008
	V4NCE..	1.3	4,676	0.13	0,467	11.5	0,453	10,2 ± 0.7	0,401 ± 0.027	0.2	0,008
	V4NCS..	1.8	6,474	0.2	0,719	10.7	0,421	9,3 ± 0.7	0,366 ± 0.027	0.2	0,008
	V4NCSE..	1.8	6,474	0.2	0,719	11.5	0,453	10,1 ± 0.7	0,397 ± 0.027	0.2	0,008
Width of lever 4.0mm/0.16 in											
	V4NC..	1.3	4,676	0.13	0,467	15.8	0,622	14,7 ± 0.6	0,579 ± 0.023	0.2	0,008
	V4NCE..	1.3	4,676	0.13	0,467	16.5	0,649	15,4 ± 0.6	0,606 ± 0.023	0.2	0,008
	V4NCS..	1.8	6,474	0.2	0,719	15.8	0,622	14,7 ± 0.6	0,579 ± 0.023	0.2	0,008
	V4NCSE..	1.8	6,474	0.2	0,719	16.5	0,649	15,4 ± 0.6	0,606 ± 0.023	0.2	0,008
Width of lever 4.0mm/0.16 in											

Operating characteristics shown above are specified from mounting hole centres.

Over travel: Flush with case. (7.8 mm min) The case should not be used as an end stop.

Ordering Reference

Basic type	V4NC	Example: V4NC	E	T7	C2	A1	0	G
Actuating Force	No symbol, standard force							
Type of sealing	No symbol, unsealed, standard travel							
E	Unsealed with extended overtravel (0.5 mm)							
S	Sealed IP6K7 standard travel							
B	Sealed IP6K7 with extended overtravel (0.5 mm)							
Terminals	No symbol, pre-wired 500 mm with cable box (V4NCS/B only)							
T7	Solder 2.95 × 0.5 × 3.55 long							
T8	PCB 0.8 × 0.5 × 4.0 long							
T9	Faston 2.8 × 0.5 × 9.5 long							
T81	Formed PCB 0.8 × 0.5 × 3.8 long							
T82	Formed PCB 0.8 × 0.5 × 3.8 long							
T84	Short PCB 0.8 × 0.5 × 2.0 long							
T85	Long PCB 0.8 × 0.5 × 6.85 long							
T11	Welding/solder 2.95 × 0.5 × 3.55 long							
Circuit	No symbol, change-over							
C2	Normally closed							
C4	Normally open							
Actuators	No symbol, without lever							
A1	Plain lever 18.0 mm							
A2	Plain lever 25.0 mm							
A3	Plain lever 32.0 mm							
A7	Plain lever 60.0 mm							
AC	Cam follower lever 18.5 mm (AC1)							
AR	Roller lever 16.0 mm (AR1)							
AP	Roller lever 17.9 mm (AR2)							
PB	Push Button (see specification PBA4/QA4)							
QA	Push Button (see specification PBA4/QA4)							
	Other actuators on special request							
Actuator Position	No symbol, without lever, or lever fitted at the end nearest to the Plunger							
0	With lever fitted at end opposite to plunger							
Contact Material	No symbol, Ag							
G	Gold plate on silver (GP)							
X	Gold alloy on silver palladium crosspoint (AUX)							
	Other contact materials on special request							
Special Features	/ <input type="checkbox"/> <input type="checkbox"/> <input type="checkbox"/> <input type="checkbox"/> Saia specialise in customer specific solutions. Additional product variants are available or can be provided. If your requirements cannot be satisfied from the options listed, please contact www.saia-burgess.com or your local SB outlet.							

Thermoset plastic Microswitches



Circuit diagram

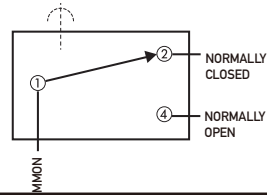

Dimension

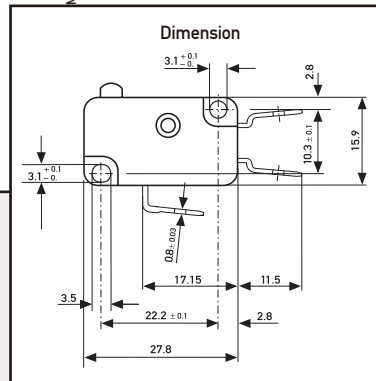

XG

- Characteristics
- wide range of forces and ratings
 - long mechanical and electrical life
 - solder, faston and PCB terminals
 - compliant to IEC 60335-1, 4. ed.

Rating 250 VAC, 26 A max.

Dimensions (mm) 27.8 × 15.9 × 10.3

- Actuator
- plunger
 - plain levers
 - roller levers
 - simulated roller levers

Approvals ENEC, UL, cUL, CSA



Preferred Range

Ordering Reference	Actuating Force		Operating pos.		Terminal	Circuit	Actuator	Contacts	Electrical rating	
	(N)	(ozf)	(mm)	(in)					ENEC	UL/CSA
XGG2-88Z1	3.20	11.43	14.7	0.57	Faston	CO	Plunger	Ag / AgNi10	16(6) A	15 A
XGG2-88-J23Z1	1.40	5.03	14.9	0.59	Faston	CO	Plain lever	Ag / AgNi10	16(6) A	15 A
XGG2-88-J26Z1	0.91	3.27	14.5	0.57	Faston	CO	Plain lever	Ag / AgNi10	16(6) A	15 A
XGG2-88-J27Z1	0.65	2.34	13.7	0.54	Faston	CO	Plain lever	Ag / AgNi10	16(6) A	15 A
XGG2-88-S20Z1	3.20	11.43	20.2	0.79	Faston	CO	Roller lever	Ag / AgNi10	16(6) A	15 A
XGG2-88-S21Z1	1.55	5.57	20.1	0.79	Faston	CO	Roller lever	Ag / AgNi10	16(6) A	15 A
XGG3-88Z1	3.20	11.43	14.7	0.57	Solder	CO	Plunger	Ag / AgNi10	16(6) A	15 A
XGG6-88Z1	3.20	11.43	14.7	0.57	Faston	CO	Plunger	Ag / AgNi10	16(6) A	15 A
XGC2-88Z1	0.80	2.86	14.7	0.57	Faston	CO	Plunger	Ag / AgNi10	12(6) A	10 A
XGC2-88-J23Z1	0.35	1.26	15.0	0.59	Faston	CO	Plain lever	Ag / AgNi10	12(6) A	10 A
XGC2-88-S20Z1	0.80	2.86	20.2	0.79	Faston	CO	Roller lever	Ag / AgNi10	12(6) A	10 A
XGC6-88Z1	0.80	2.86	14.7	0.57	Faston	CO	Plunger	Ag / AgNi10	12(6) A	10 A
XGK2-88Z1	1.50	5.36	14.7	0.57	Faston	CO	Plunger	Ag / AgNi10	12(6) A	12 A
XGK2-88-J26Z1	0.43	1.55	14.7	0.57	Faston	CO	Plain lever	Ag / AgNi10	12(6) A	12 A
XGK2-88-S21Z1	0.71	2.55	20.2	0.80	Faston	CO	Roller lever	Ag / AgNi10	12(6) A	12 A
XGK3-88Z1	1.50	5.36	14.7	0.57	Solder	CO	Plunger	Ag / AgNi10	12(6) A	12 A
XGK6-88Z1	1.50	5.36	14.7	0.57	Faston	CO	Plunger	Ag / AgNi10	12(6) A	12 A
XG02-88Z1	1.20	4.29	14.5	0.57	Faston	CO	Plunger	Ag / AgNi10	16(6) A	15 A
XG02-88-J27Z1	0.25	0.90	13.6	0.54	Faston	CO	Plain lever	Ag / AgNi10	16(6) A	15 A
XG02-88-S20Z1	1.20	4.29	20.1	0.79	Faston	CO	Roller lever	Ag / AgNi10	16(6) A	15 A
XG06-88Z1	1.20	4.29	14.5	0.57	Faston	CO	Plunger	Ag / AgNi10	16(6) A	15 A

Specifications

Housing	Melamine-Formaldehyd. Thermosetting
Plunger	POM, PPS, MF depending on temperature /type
Mechanism	Snap-action, single pole beryllium bronze blade mechanisme with wiping contacts
Functions	Change-over, normally-closed (except XGG and XGK) or normally-open
Contacts	Fine silver (Ag), silver nickel (AgNi10), gold-plated (Au), silver cadmium oxide (AgCdO)
Terminals	Solder, faston, screw, PCB and side mounting PCB terminals. RAST 5 terminals (5.0 mm pitch)
Temperature range °C	-40° C to +150° C
Mechanical life	2,5 · 10 ⁵ cycles minimum, 50 · 10 ⁶ cycles maximum (Actuation: sinusoidal and maximum up to 80% of the overtravel)
Protection	Enclosure IP40
Mounting	Side mounting via mounting holes
Actuators	Stainless steel

Circuit diagram

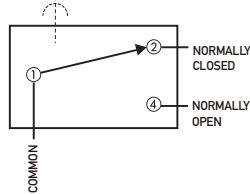

Actuating force/travel

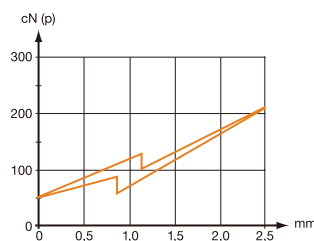

Contact force/travel

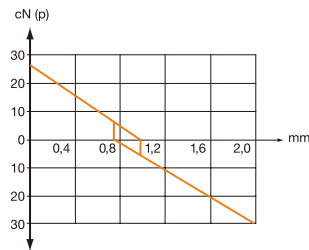

Dimensions

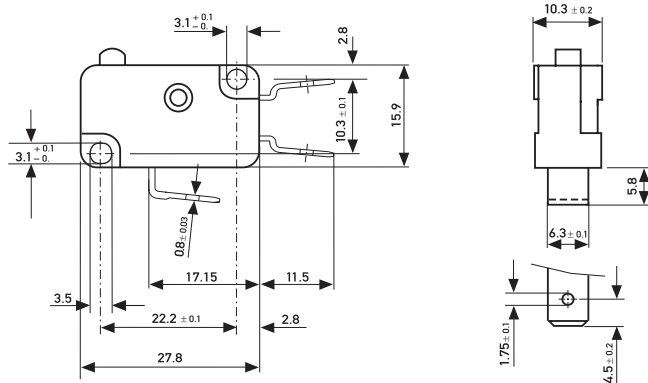

Maximum DC rating

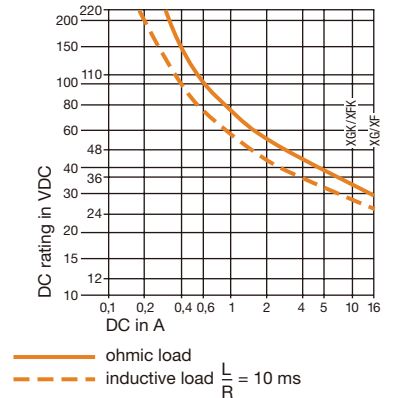

Recommended maximum electrical ratings

	Voltage (VAC)	Approvals ENEC	UL	(VAC)		Voltage (VAC)	Approvals ENEC	UL	(VAC)
XGG...-88	250	16 (6) 5E4	15 A	125/250	XGT...-86	250	26 (10) 25E3	25A	125/250
XGA...-88	250	16 (6) 5E4	15 A	125/250	XGD...-86	250	22 (6) 5E4	21A	125/250
XGM...-88	250	16 (6) 5E4	15 A	125/250	XGA...-86	250	20 (8) 5E4	15A	125/250
XGO...-88	250	16 (6) 5E4	15 A	125/250	XGM...-86	250	20 (8) 5E4	15A	125/250
XGB...-88	250	12 (6) 5E4	12 A	125/250	XGO...-86	250	20 (8) 5E4	15A	125/250
XGC...-88	250	12 (6) 5E4	10 A	125/250	XGA...-86	400	10 (6) 5E4	-	-
XGH...-88	250	12 (6) 5E4	10 A	125/250	XGG...-86	400	10 (6) 5E4	-	-
XGK...-88	250	12 (6) 5E4	12 A	125/250	XGM...-86	400	10 (6) 5E4	-	-
XG...-88	400	3 (2) 5E4	-	-	XGO...-86	400	10 (6) 5E4	-	-

Operating Characteristics

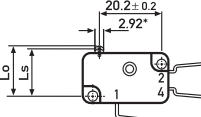
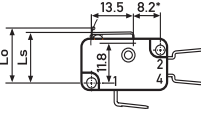
Actuator	Reference	Actuating Force		Release Force		Free Position		Operating Position		Movement Differential		Total travelled position		
		Maximum (N)	(ozf)	Minimum (N)	(ozf)	Maximum (mm)	(in)	(mm)	(in)	Maximum (mm)	(in)	(mm)	(in)	
	XGG..	3,2	11,43	0,4	1,43	15,75	0,62	14,7	0,57	} +0,2 } -0,4 } +0,007 } -0,015	0,35	0,013	13,2	0,519
	XGA..	3,2	11,43	0,6	2,14	15,75	0,62	14,7	0,57		0,15	0,006	13,2	0,519
	XGM..	2	7,14	0,5	1,79	15,6	0,61	14,5	0,57		0,35	0,013	13,7	0,539
	XGO..	1,2	4,29	0,1	0,36	15,6	0,61	14,5	0,57		0,35	0,013	13,7	0,539
	XGK..	1,5	5,36	0,2	0,71	15,75	0,62	14,7	0,57		0,35	0,013	13,2	0,519
	XGB..	1,5	5,36	0,3	1,07	15,75	0,62	14,7	0,57		0,15	0,006	13,2	0,519
	XGC..	0,8	2,86	0,1	0,36	15,75	0,62	14,7	0,57		0,15	0,006	13,2	0,519
	XGH..	0,45	1,61	0,05	0,18	15,6	0,61	14,5	0,57		0,35	0,013	13,7	0,539
	XGT	3,2	11,43	0,6	2,14	15,75	0,62	14,7	0,57		0,15	0,006	13,2	0,519
	XGD..	1,7	6,07	0,15	0,54	15,75	0,62	14,7	0,57		0,15	0,006	13,2	0,519
	XGG..	3,2	11,43	0,36	1,29	16,5	0,64	15,1 ± 0,5	0,59 ± 0,019	0,4	0,015	14	0,551	
	XGA..	3,2	11,43	0,54	1,93	16,5	0,64	15,1 ± 0,5	0,59 ± 0,019	0,2	0,007	14	0,551	
	XGM..	2	7,14	0,45	1,61	16,5	0,64	15 ± 0,5	0,59 ± 0,019	0,4	0,015	14,4	0,566	
	XGO..	1,2	4,29	0,09	0,34	16,5	0,64	15 ± 0,5	0,59 ± 0,019	0,4	0,015	14,4	0,566	
	XGK..	1,5	5,36	0,18	0,64	16,5	0,64	15,1 ± 0,5	0,59 ± 0,019	0,4	0,015	14	0,551	
	XGB..	1,5	5,36	0,27	0,96	16,5	0,64	15,1 ± 0,5	0,59 ± 0,019	0,2	0,007	14	0,551	
	XGC..	0,8	2,86	0,09	0,32	16,5	0,64	15,1 ± 0,5	0,59 ± 0,019	0,2	0,007	14	0,551	
	XGH..	0,45	1,61	0,04	0,14	16,5	0,64	15 ± 0,5	0,59 ± 0,019	0,4	0,015	14,4	0,566	

Width of lever 7 mm/0.28 in – also available with width 4 mm/0.16 in

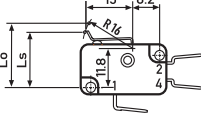
	XGG..	2,6	9,29	0,32	1,14	19,2	0,75	17,5 ± 0,7	0,68 ± 0,027	0,45	0,017	16,4	0,645
	XGA..	2,6	9,29	0,48	1,71	19,2	0,75	17,5 ± 0,7	0,68 ± 0,027	0,2	0,007	16,4	0,645
	XGM..	1,65	5,89	0,4	1,43	19,2	0,75	17,3 ± 0,7	0,68 ± 0,027	0,45	0,017	16,9	0,665
	XGO..	1	3,57	0,08	0,29	19,2	0,75	17,3 ± 0,7	0,68 ± 0,027	0,45	0,017	16,9	0,665
	XGK..	1,25	4,46	0,16	0,57	19,2	0,75	17,5 ± 0,7	0,68 ± 0,027	0,45	0,017	16,4	0,645
	XGB..	1,25	4,46	0,24	0,86	19,2	0,75	17,5 ± 0,7	0,68 ± 0,027	0,2	0,007	16,4	0,645
	XGC..	0,65	2,32	0,08	1,29	19,2	0,75	17,5 ± 0,7	0,68 ± 0,027	0,2	0,007	16,4	0,645
	XGH..	1,37	1,32	0,04	0,14	19,2	0,75	17,3 ± 0,7	0,68 ± 0,027	0,45	0,017	16,9	0,665

Width of lever 7 mm/0.28 in

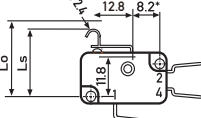
	XGG..	3,2	11,43	0,38	1,36	21,8	0,85	20,5 ± 0,6	0,81 ± 0,023	0,4	0,015	19,5	0,767
	XGA..	3,2	11,43	0,85	3,04	21,8	0,85	20,5 ± 0,6	0,81 ± 0,023	0,2	0,007	19,5	0,767
	XGM..	2	7,14	0,48	1,71	21,8	0,85	20,3 ± 0,6	0,8 ± 0,023	0,4	0,015	19,8	0,779
	XGO..	1,2	4,29	0,09	0,32	21,8	0,85	20,1 ± 0,6	0,79 ± 0,023	0,4	0,015	19,8	0,779
	XGK..	1,5	5,36	0,19	0,68	21,8	0,85	20,5 ± 0,6	0,81 ± 0,023	0,4	0,015	19,5	0,767
	XGB..	1,5	5,36	0,29	1,04	21,8	0,85	20,5 ± 0,6	0,81 ± 0,023	0,2	0,007	19,5	0,767
	XGC..	0,8	2,86	0,09	0,32	21,8	0,85	20,5 ± 0,6	0,81 ± 0,023	0,2	0,007	19,5	0,767
	XGH..	0,45	1,61	0,04	0,14	21,8	0,85	20,3 ± 0,6	0,8 ± 0,023	0,4	0,015	19,8	0,779

Width of lever 7 mm/0.28 in

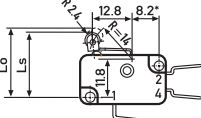
	XGG..	3,2	11,43	0,37	1,32	21,8	0,85	20,2 ± 0,7	0,79 ± 0,027	0,4	0,015	19,3	0,759
	XGA..	3,2	11,43	0,56	2	21,8	0,85	20,2 ± 0,7	0,79 ± 0,027	0,2	0,007	19,3	0,759
	XGM..	2	7,14	0,47	1,68	21,8	0,85	20,1 ± 0,7	0,79 ± 0,027	0,4	0,015	19,7	0,775
	XGO..	1,2	4,29	0,09	0,32	21,8	0,85	20,1 ± 0,7	0,79 ± 0,027	0,4	0,015	19,7	0,775
	XGK..	1,5	5,36	0,18	0,64	21,8	0,85	20,2 ± 0,7	0,79 ± 0,027	0,4	0,015	19,3	0,759
	XGB..	1,5	5,36	0,28	1	21,8	0,85	20,2 ± 0,7	0,79 ± 0,027	0,2	0,007	19,3	0,759
	XGC..	0,8	2,86	0,09	0,32	21,8	0,85	20,2 ± 0,7	0,79 ± 0,027	0,2	0,007	19,3	0,759
	XGH..	0,45	1,61	0,04	0,14	21,8	0,85	20,1 ± 0,7	0,79 ± 0,027	0,4	0,015	19,7	0,775

Width of roller 6.6 mm/0.26 in

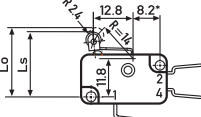
	XGG..	3,2	11,43	0,37	1,32	21,8	0,85	20,2 ± 0,7	0,79 ± 0,027	0,4	0,015	19,3	0,759
	XGA..	3,2	11,43	0,56	2	21,8	0,85	20,2 ± 0,7	0,79 ± 0,027	0,2	0,007	19,3	0,759
	XGM..	2	7,14	0,05	1,68	21,8	0,85	20,1 ± 0,7	0,79 ± 0,027	0,4	0,015	19,7	0,775
	XGO..	1,2	4,29	0,09	0,32	21,8	0,85	20,1 ± 0,7	0,79 ± 0,027	0,4	0,015	19,7	0,775
	XGK..	1,5	5,36	0,18	0,64	21,8	0,85	20,2 ± 0,7	0,79 ± 0,027	0,4	0,015	19,3	0,759
	XGB..	1,5	5,36	0,28	1	21,8	0,85	20,2 ± 0,7	0,79 ± 0,027	0,2	0,007	19,3	0,759
	XGC..	0,8	2,86	0,09	0,32	21,8	0,85	20,2 ± 0,7	0,79 ± 0,027	0,2	0,007	19,3	0,759
	XGH..	0,45	1,61	0,04	0,14	21,8	0,85	20,1 ± 0,7	0,79 ± 0,027	0,4	0,015	19,7	0,775

Width of roller 6.6 mm/0.26 in

1) Lever distance 8.2 (0.32) for lever position –20, lever position (-J20, L20, S20, M20)
Lever distance 14.0 (0.55) for lever position –40, lever position (-J40, L40, S40, M40)

* For high temperature T125° C/T 150° C (ENEC, UL)

Ordering Reference

Basic type	XGG..	3,2 N	11,43 ozf	Example: XG	4	2	A	-88	J20	Z1
	XGA..	3,2 N	11,43 ozf							
	XGM..	2,0 N	7,14 ozf							
	XGO..	1,2 N	4,29 ozf							
	XGK..	1,5 N	5,36 ozf							
	XGB..	1,5 N	5,36 ozf							
	XGC..	0,8 N	2,86 ozf							
	XGH..	0,45 N	1,61 ozf							
	XGD..	1,7 N	6,07 ozf							
	XGT..	3,2 N	11,43 ozf							

Circuit	No symbol, change-over
4	Normally closed (NC)
5	Normally open (NO)

Terminals	2	Faston	6,3 × 0,8
	3	Solder	1,7 × 3,2
	4	Faston	1 × 2,8 × 0,5 DIN
	5	Faston	1 × 2,8 × 0,5
	6	Faston	4,8 × 0,5
	7	Screw	
	8	Faston	1 × 2,8 × 0,8 DIN
	9	Faston	1 × 2,8 × 0,8
	10	Faston	4,8 × 0,8
	11	Faston	2 × 2,8 × 0,8
	12	Short solder	∅ 2,3
	13	Print bent (lid)	
	14	Print bent (base)	
	15	Rast 5	6,3 × 0,8
	19	Short solder	∅ 1,7

Other types of terminals are available on request

Version	ENEC	UL	Number of operations at rated load	
			Europe	UL
	No symbol, T85	T90	50.000	6.000
A	T85	T90	50.000	100.000
W	T150	T150	50.000	6.000
AW	T150	T150	50.000	100.000
B	T85	T90	10.000	6.000
V	T125	T130	50.000	6.000
AV	T125	T130	50.000	100.000
C	T85	T90	25.000	6.000

Contacts	-88	Ag / AgNi10
	-81	Gold-plated 4 µm (Au) on Ag
	-86	Ag / Ag CdO

Actuators	No symbol, plunger		
	J20 ¹⁾	J40 ²⁾	Plain lever 13,5 mm
	J22 ¹⁾	J42 ²⁾	Plain lever 24,0 mm
	J23 ¹⁾	J43 ²⁾	Plain lever 27,8 mm
	J27 ¹⁾	J47 ²⁾	Plain lever 60,0 mm
	M20 ¹⁾	M40 ²⁾	Plain lever formed 14,7 mm
	L20 ¹⁾	L40 ²⁾	Cam follower 12,8 mm
	L21 ¹⁾	L41 ²⁾	Cam follower 26,2 mm
	S20 ¹⁾	S40 ²⁾	Roller lever 12,8 mm
	T20 ¹⁾	T40 ²⁾	Roller lever, 150°C version 12,8 mm

Other actuators available on request

- ¹⁾ Lever distance 8.2 (0.32) for lever position –20, lever position (–J20, L20, S20, M20)
²⁾ Lever distance 14.0 (0.55) for lever position –40, lever position (–J40, L40, S40, M40)

Approvals	No symbol, ENEC
Z1	UL, CSA

Thermoplastic Microswitches



Circuit diagram

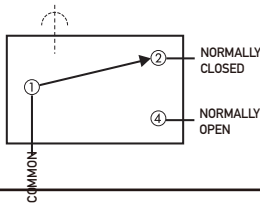

Dimension

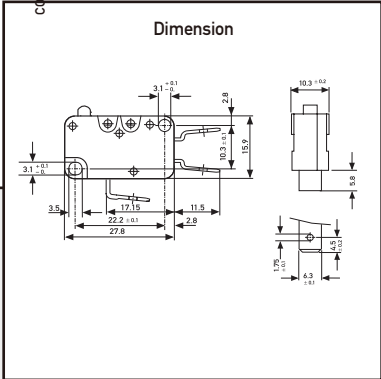

innovating motion

X3

X3

Characteristics	<ul style="list-style-type: none"> ■ 8 mm creepage and clearance distance to the actuator ■ long mechanical and electrical life ■ solder, faston and PCB terminal
Rating	250 VAC, 21 A max.
Dimensions (mm)	27,8 × 15,9 × 10,3
Actuator	<ul style="list-style-type: none"> ■ plunger ■ straight lever ■ simulated roller levers ■ roller levers
Approvals	UL, cUL, CSA, ENEC, CQC



Preferred Range

Ordering Reference	Actuating Force (N)	(ozf)	Operating pos. (mm)	Terminal	Circuit	Actuator	Contacts	Electrical rating ENEC	UL/CSA
X3M302K2KA	1,60	5,72	14,7 +0.2/-0.4	Faston	C0	Plunger	Ag/AgNi10	16 (6) A	20.5 A
X3M302K2KAJ32	0,88	3,15	15 ± 1,0	Faston	C0	Plain lever	Ag/AgNi10	16 (6) A	20.5 A
X3M302K2KAJ62	0,57	2,04	14,8 ± 1,5	Faston	C0	Plain lever	Ag/AgNi10	16 (6) A	20.5 A
X3M302K2KAT02	2,00	7,15	20,2 ± 0,7	Faston	C0	Roller lever	Ag/AgNi10	16 (6) A	20.5 A
X3M303K2KA	1,60	5,72	14,7 +0.2/-0.4	Solder	C0	Plunger	Ag/AgNi10	16 (6) A	20.5 A
X3M306K2KA	1,60	5,72	14,7 +0.2/-0.4	Faston	C0	Plunger	Ag/AgNi10	16 (6) A	20.5 A
X3C302K2LB	0,80	2,86	14,7 +0.2/-0.4	Faston	C0	Plunger	Ag/AgNi10	10 (3) A	12 A
X3C302K2LBJ32	0,35	1,25	15 ± 1,0	Faston	C0	Plain lever	Ag/AgNi10	10 (3) A	12 A
X3C303K2LB	0,80	2,86	14,7 +0.2/-0.4	Solder	C0	Plunger	Ag/AgNi10	10 (3) A	12 A
X3C306K2LB	0,80	2,86	14,7 +0.2/-0.4	Faston	C0	Plunger	Ag/AgNi10	10 (3) A	12 A
X3L302K6DD	1,50	5,36	14,7 +0.2/-0.4	Faston	C0	Plunger	Ag/AgCdO	21 (8) A	21 A
X3L303K6DD	1,50	5,36	14,7 +0.2/-0.4	Solder	C0	Plunger	Ag/AgCdO	21 (8) A	21 A

Specifications

Housing	Thermoplastic
Plunger	Thermoplastic
Mechanism	Snap-action, single pole beryllium bronze blade mechanism with wiping contacts
Contact carrier	Brass
Contacts	Fine silver (Ag), silver nickel (AgNi10), gold-plated (Au), silver cadmium oxide (AgCd0)
Terminals	Solder, Faston and RAST 5 terminals
Temperature range °C	Between -40°C and +125°C
Mechanical life	minimum cycles X3L: 10 ⁵ /X3M: 10 ⁴ /X3C: 2 · 10 ⁶ (Actuation: sinusoidal and maximum up to 80% of the overtravel)
Protection	Enclosure IP40
Mounting	Side mounting via mounting holes
Actuators	Stainless steel (lever)

Circuit diagram

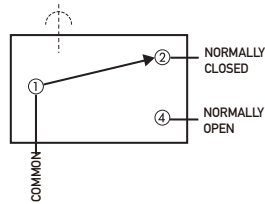

Actuating force/travel

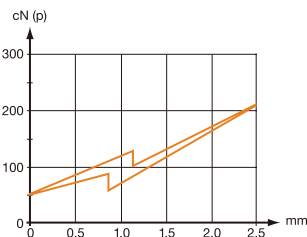

Contact force/travel

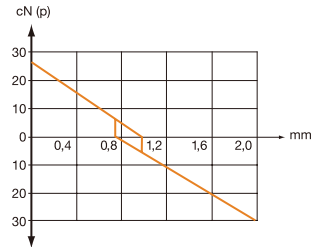

Dimensions

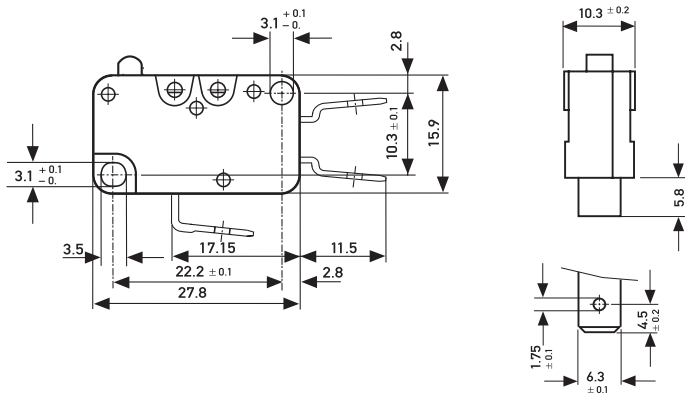

Maximum DC rating

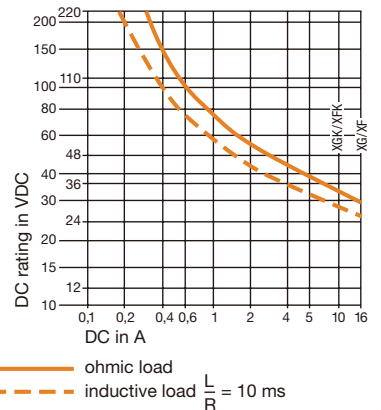

Recommended maximum electrical ratings

	Voltage (VAC)	Resistive load (A)	Motor load (A)	Approvals ENEC (A)	(VAC)	Approvals UL (A)	(VAC)	Motor load
X3M	250	16	6	16 (6)	5E4	20,5	250	1½ HP
X3C	250	10	3	10 (3)	5E4	12	250	½ HP
X3L	250	21	8	21 (8)	1E4	21	250	2 HP
						21	125	1 HP

Current breaking capacities in the tables refer to Ag/AgNi10 contacts with the exception of X3L Ag/AgCd0

Operating Characteristics

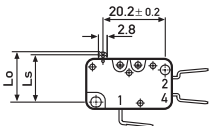
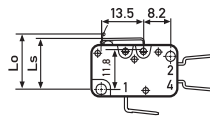
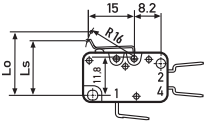
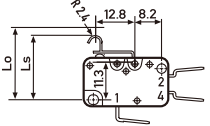
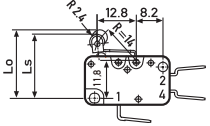
Actuator	Reference	Actuating Force		Release Force		Free Position		Operating Position		Movement Differential		Full overtravel position			
		(N)	(ozf)	(N)	(ozf)	(mm)	(in)	(mm)	(in)	(mm)	(in)	(mm)	(in)		
Plunger 	X3C3	0.8	2.877	0.05	0.179	15.75	0.62	14.7	+0.2	0.578	+0.008	0.25	0.009	13.2	0.52
	X3M3	1.6	5.755	0.2	0.719	15.75	0.62	14.7	-0.4	0.578	-0.006	0.25	0.009	13.2	0.52
J02 Lever 	X3C3 ..	0.8	2.877	0.045	0.161	16.5	0.649	15.1 ± 0.5	0.59 ± 0.02	0.35	0.014	14	0.55		
	X3M3..	2	7.193	0.18	0.647	16.5	0.649	15.1 ± 0.5	0.59 ± 0.02	0.35	0.014	14	0.55		
Width of lever 7.0 mm / 0.28 in – also available with width 4 mm / 0.16 in															
M02 Lever 	X3C3 ..	0.5	1.798	0.04	0.143	19.2	0.755	17.5 ± 0.7	0.69 ± 0.028	0.35	0.014	16.4	0.65		
	X3M3..	1.65	5.934	0.16	0.575	19.2	0.755	17.5 ± 0.7	0.69 ± 0.028	0.35	0.014	16.4	0.65		
Width of lever 7.0 mm / 0.28 in															
L02 Lever 	X3C3 ..	0.8	2.877	0.045	0.161	21.8	0.858	20.5 ± 0.6	0.81 ± 0.024	0.35	0.014	19.5	0.76		
	X3M3..	2	7.193	0.19	0.683	21.8	0.858	20.5 ± 0.6	0.81 ± 0.024	0.3	0.011	19.5	0.76		
Width of lever 7.0 mm / 0.28 in															
T02 Lever 	X3C3 ..	0.8	2.877	0.045	0.161	21.8	0.858	20.2 ± 0.7	0.79 ± 0.028	0.35	0.014	19.3	0.76		
	X3M3..	2	7.193	0.19	0.683	21.8	0.858	20.2 ± 0.7	0.79 ± 0.028	0.35	0.014	19.3	0.76		
Width of roller 6.6 mm / 0.26 in															

Ordering Reference

Basic type	X3	Microswitch according to DIN 41635, Design A	Example: X3	M	3	02	K	2	A	A	J0	2	AA
Operating force	M	Standard force 1											
	L	Standard force 2											
	C	Low force											
Circuit diagram	3	Change-over											
	4	Normally closed (NC)											
	5	Normally open (NO)											
Terminals	02	Plug terminal 6.3 × 0.8 mm	13	PCB-terminal, Formed to lid									
	03	Solder terminal	14	PCB-terminal, Formed to base									
	06	Plug terminal 4.8 × 0.5 mm	15	Plug terminal RAST 5 6.3 × 0.8 mm									
	10	Plug terminal 4.8 × 0.8 mm	16	Plug terminal RAST 5 4.8 × 0.8 mm									
	12	Solder terminal, short											
Body	K	PA66 GF25											
	N	Compliant to glow wire requirements as to IEC 60335-1, 4. ed.											
Contacts materials	2	Silver/AgNi10											
	6	AgCd0											
	8	Gold plated											
UL/C-UL ratings	A	20.5 A, 125/250 VAC 15 A, 125/250 VAC, 100'000 cy. 1½ HP, 250 VAC, ½ HP, 125 VAC	M	6 A, 125/250 VAC ½ HP, 250 VAC, ½ HP, 125 VAC									
	D	21 A, 125/250 VAC 2 HP, 250 VAC, 1 HP, 125 VAC	N	No approvals									
	E	21 A, 125/250 VAC 15 A, 125/250 VAC, 100'000 cy. 2 HP, 250 VAC, 1 HP, 125 VAC	P	20.5 A, 125/250 VAC 1½ HP, 250 VAC, ½ HP, 125 VAC ¼ HP, 250 VDC, ½ HP, 125 VDC									
	K	20.5 A, 125/250 VAC 1½ HP, 250 VAC, ½ HP, 125 VAC	Q	12 A, 125/250 VAC ½ HP, 250 VAC, ½ HP, 125 VAC ¼ A, 250 VDC, ½ A, 125 VDC									
	L	12 A, 125/250 VAC ½ HP, 250 VAC, ½ HP, 125 VAC	R	6 A, 125/250 VAC ½ HP, 250 VAC, ½ HP, 125 VAC ¼ A, 250 VDC, ½ A, 125 VDC									
EN/IEC ratings	A	16 (6) A, 250 V~ 5E4 T125 µ approved											
	B	10 (3) A, 250 V~ 5E4 T125 µ approved											
	C	6 (3) A, 250 V~ 5E4 T125 µ approved											
	D	21 (8) A, 250 V~ 1E4 T105 µ approved											
Type of actuator		No symbol, without lever											
	J0 to J9	Straight lever (width 7 mm)											
	L0 to L9	Simulated roller lever											
	M0 to M9	Customer specified lever (KV)											
	P0 to P9	Straight lever (width 4 mm)											
	T0 to T9	Roller lever											
	U0 to U9	Outside mounted lever											
Actuator position		No symbol, without lever											
	2	Rear lever											
	4	Front lever											
Customer version		No symbol, standard type											
	AA to YY	Specials for customers											

High rating and 3 mm contact gap Microswitches



Circuit diagram

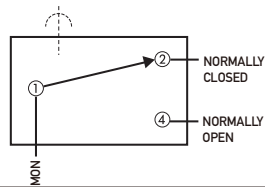

Dimension

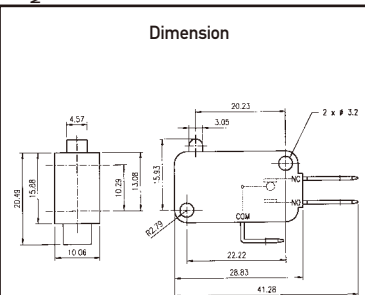

390

Characteristics ■ wiping contacts, leaf spring mechanism
 ■ Rast 5 terminal option

Rating 250 VAC, 25 A max.

Dimensions 28.8 × 20.4 × 10.1

Actuator ■ plunger
 ■ plain levers
 ■ roller levers
 ■ moulded lever

Approvals ENEC, UL, CSA



Popular Products

Ordering Reference	Actuating Force (g)	Operating pos. (mm)	Terminal	Contact Gap (mm)	Actuator	Contacts	Electrical rating ENEC	UL
393/40/120	120	14,4–15,17	6.35 × 0.8	1	Plunger	Ag	22 (4) A 250 VAC	22 A 1HP 125/250VAC
393/40/350	350	14,4–15,17	6.35 × 0.8	1	Plunger	Ag	20 (4) A 250 VAC	20 A 1HP 125/250 VAC

Specifications

Housing	Glass-filled flame retardant Nylon 6.6
Plunger	Glass-filled flame retardant Nylon 6.6
Mechanism	Snap action, single pole leaf spring mechanism
Functions	Change over, Normally open, Normally closed
Contacts	Silver
Terminals	Solder, Faston and Rast 5 terminals
Temperature range	-10°C to +85°C
Mechanical life	10 ⁷ cycles minimum (impact-free actuation)
Protection	IP40 (enclosure)
Mounting	Side mounting
Actuators	Plunger, plain lever, roller lever

Circuit diagram

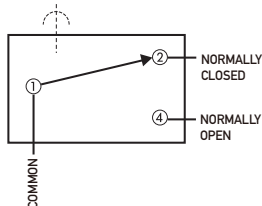

Dimensions

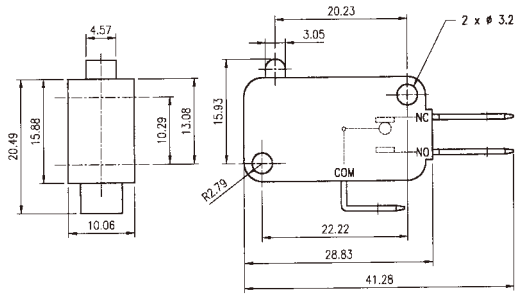

392
Solder

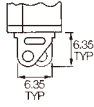

398
Rast 5
Fast on

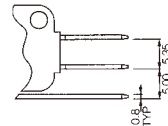
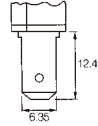

393
6.35 x 0.8
Fast on

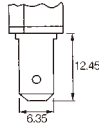

Recommended maximum electrical ratings A3 shown below

Versions	ENEC	UL
120 g (only for NO/NC)	22 (4) A, 250 VAC, 50E3, T85	22 A 1HP 125/250 VAC T85
350 g (only for NO/NC)	25 (4) A, 250 VAC, 50E3, T85	22 A 1HP 125/250 VAC T85
CO	20 (4) A, 250 VAC, 10E3, T85	20A, 1HP 125/250 VAC

Operating Characteristics

Actuator	Reference	Actuating Force Maximum (g)	Release Force Minimum (g)	Free Position Maximum (mm)	Operating Position	Length (mm)	Movement Differential Maximum (mm)	Overtravel Minimum (mm)
Plunger	39-/40/120	120	40	15.93	14,4-15,17		0,25	1,32
	39-/120/350	350	100	15.93	14,4-15,17		0,25	1,32
Plain lever (Back position)	ZD0			16,99		22,56		
	ZD1			18,61		33,9		
	ZD2			25,8		84,43		
Roller lever	ZDS0			22,15		19,67		
	ZDS1			23,86		31,7		

Ordering Reference

Basic type	39	Example: 39				2/	40/	120	NO	ZD0
Terminal type	2	Solder								
	3	6,35 × 0,8 fast-on								
	8	6,35 × 0,8 Rast 5								
Contact gap	40	1 mm standard								
Operating force	120	120 g								
	350	350 g								
Circuit	No symbol, change-over									
	NO	Normally open								
	NC	Normally closed								
Actuator	No symbol, plunger									
	ZD0	Plain lever	22,5 mm							
	ZD1	Plain lever	33,9 mm							
	ZD2	Plain lever	84,4 mm							
	ZDS0	Roller lever	19,67 mm							
	ZDS1	Roller lever	31,7 mm							

340

Characteristics ■ wiping contacts, leaf spring mechanism
 ■ 3 mm contact gap option

Rating 250 VAC, 16 A max.

Dimensions 28.8 × 20.4 × 10.1

Actuator ■ plunger
 ■ roller lever
 ■ plain levers
 ■ simulated roller lever
 ■ moulded lever

Approvals ENEC



Popular Products

Ordering Reference	Actuating Force (g)	Operating pos. (mm)	Terminal	Contact Gap (mm)	Actuator	Contacts	Electrical rating ENEC	UL/CSA
343/40/75	75	14,4–15,17	6,35 × 0,8	1	Plunger	AgCd0	16,1 A, 250 VAC	10 A

Specifications

Housing	Glass-filled flame retardant Nylon 6,6
Plunger	Glass-filled flame retardant Nylon 6,6
Mechanism	Snap action, single pole leaf spring mechanism
Functions	Change-over, Normally open, Normally closed
Contacts	Silver
Terminals	Solder, Faston and Rast 5 terminals
Temperature range	-10°C to +85°C
Mechanical life	10 ⁷ cycles minimum (3 mm gap 10 ⁶) (impact-free actuation)
Protection	IP40 (enclosure)
Mounting	Side mounting
Actuators	Plunger, plain lever, roller lever

Circuit diagram

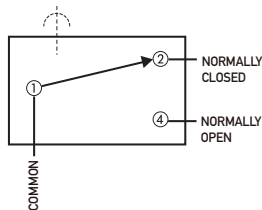

Dimensions

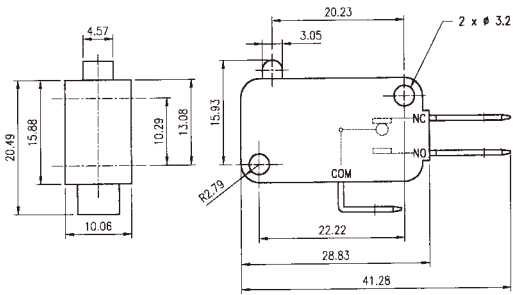

342
Solder

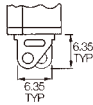

345
4,75 × 0,5
Fast on

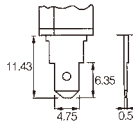

348
Rast 5
Fast on

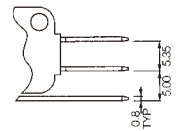
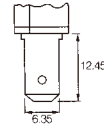

343
6,35 × 0,8
Fast on

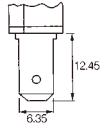

346
4,75 × 0,8
Fast on

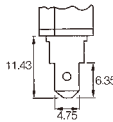

Recommended maximum electrical ratings A3 sirown below

Versions	ENEC	UL / CSA	Motor load
75 g	* 16,1 A, 250 VAC, 10 E3, T85	10 A 125/250 VAC	¼ HP
3 mm Wide gap	16(3) A, 250 VAC, 50 E3, T85	N/a	

* only for special versions
345 and 346 terminals 10 (4) A ENEC

Operating Characteristics

Actuator	Reference	Actuating Force Maximum (g)	Release Force Minimum (g)	Free Position Maximum (mm)	Operating Position	Length (mm)	Movement Differential Maximum (mm)	Overtravel Minimum (mm)
Plunger	34-/40/75	75	25	15.93	14.4-15.17		0.25	1.32
	34-/120/350	420	120	15.93	14.15-14.91		0.76	1.06
Plain lever (Back position)	ZD0			16.99		22.56		
	ZD1			18.61		33.9		
	ZD2			25.8		84.43		
Roller lever	ZDS0			22.15		19.67		
	ZDS1			23.86		31.7		

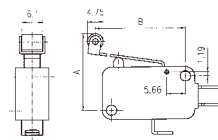
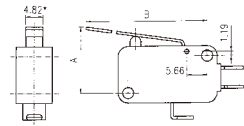

Ordering Reference

Basic type	34	Example: 34				2/	40/	75	NO	ZD0
Terminal type	2	solder								
	3	6.35 × 0.8 fast-on								
	5	4.75 × 0.5 fast-on								
	6	4.75 × 0.8 fast-on								
	8	6.35 × 0.8 Rast 5†								
Contact gap	40	1 mm standard								
	120	3 mm								
Operating force	75	75 g								
	350	420 g (3 mm gap)								
Circuit		No symbol, change-over								
	NO	Normally open								
	NC	Normally closed								
Actuator		No symbol, plunger								
	ZD0	Plain lever	22.5 mm							
	ZD1	Plain lever	33.9 mm							
	ZD2	Plain lever	84.4 mm							
	ZDS0	Roller lever	19.67 mm							
	ZDS1	Roller lever	31.7 mm							

Low operating force Microswitches



Circuit diagram

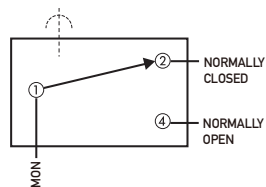

Dimension

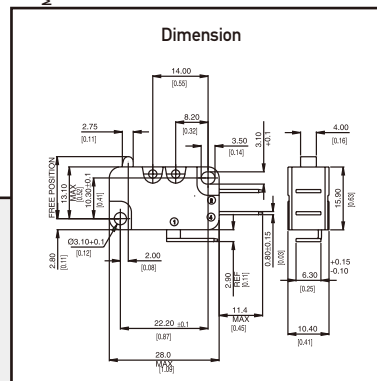

Miniature



innovating motion

G3

Characteristics	<ul style="list-style-type: none"> ■ low operating force, high current capacity ■ < 15 cn operating force option ■ > 3 mm contact gap, change-over mechanism option
Rating	Up to 250 VAC, 18 A
Dimensions (mm)	28 × 16 × 10
Actuator	<ul style="list-style-type: none"> ■ plunger ■ ramp plunger
Approvals	ENEC, UL, CSA



Preferred Range

Ordering Reference	Actuating Force (N)	Force (ozf)	Sealing	Operating pos. (mm)	Operating pos. (in)	Terminal	Circuit	Actuator	Contacts	Electrical rating
G3M1T1RULAU	0,15	0,54	IP40	14,7	0,57	Faston 6.3 × 0.8	CO	Ramp plunger	Gold plated	Up to 250 VAC, 7 A
G3M1T1PULAU	0,15	0,54	IP40	14,7	0,57	Faston 6.3 × 0.8	CO	Plain plunger	Gold plated	Up to 250 VAC, 7 A
G3M1T1RU-L	0,15	0,54	IP40	14,7	0,57	Faston 6.3 × 0.8	CO	Ramp plunger	Ag	Up to 250 VAC, 7 A
G3M1T1PUL	0,15	0,54	IP40	14,7	0,57	Faston 6.3 × 0.8	CO	Plain plunger	Ag	Up to 250 VAC, 7 A
G3M1T2RUL	0,15	0,54	IP40	14,7	0,57	Faston 4.8 × 0.8	CO	Ramp plunger	Ag	Up to 250 VAC, 7 A
G3M1T2PUL	0,15	0,54	IP40	14,7	0,57	Faston 4.8 × 0.8	CO	Plain plunger	Ag	Up to 250 VAC, 7 A
G3M1T3RUL	0,15	0,54	IP40	14,7	0,57	Faston 4.8 × 0.5	CO	Ramp plunger	Ag	Up to 250 VAC, 7 A
G3M1T3PUL	0,15	0,54	IP40	14,7	0,57	Faston 4.8 × 0.5	CO	Plain plunger	Ag	Up to 250 VAC, 7 A
G3M1T4RUL	0,15	0,54	IP40	14,7	0,57	Solder	CO	Ramp plunger	Ag	Up to 250 VAC, 7 A
G3M1T4PUL	0,15	0,54	IP40	14,7	0,57	Solder	CO	Plain plunger	Ag	Up to 250 VAC, 7 A
G3G4T1RUL	2,70	7,20	IP40	14,5	0,57	Faston 6.3 × 0.8	CO	Ramp plunger	> 3mm gap	Up to 250 VAC, 10 A
G3G4T1PUL	2,70	7,20	IP40	14,5	0,57	Faston 6.3 × 0.8	CO	Plain plunger	> 3mm gap	Up to 250 VAC, 10 A

Specifications

Housing	Flame retardant glass-filled nylon
Plunger	Flame retardant glass-filled nylon
Mechanism	Snap-action, single pole - beryllium copper trident spring
Functions	Change-over, Normally open, Normally closed
Contacts	Fixed - Silver cadmium oxide or gold plate on silver cadmium oxide, Moving - Silver or gold plate on silver
Terminals	6.3 mm (0.25 in), 4.8 mm (0.19 in) faston: NC (2), NO (4) - Brass, Common (1) - Brass, silver-plated
Temperature range °C	-40°C to + 85°C
Mechanical life	10 ⁶ to 10 ⁷ cycles minimum (impact free actuation) - dependent on operating force
Protection	IP 40 (enclosure)
Mounting	Side mounting
Actuators	Plain plunger, Ramp plunger

Circuit diagram

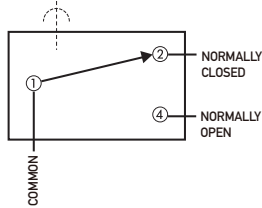

Dimensions G3M

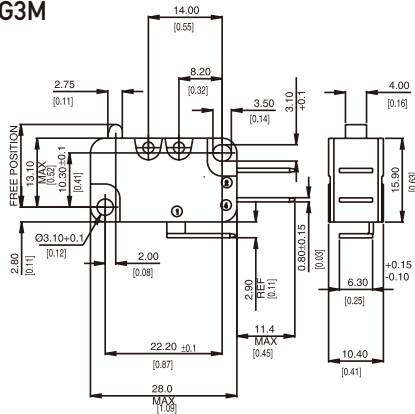

Dimensions G3G

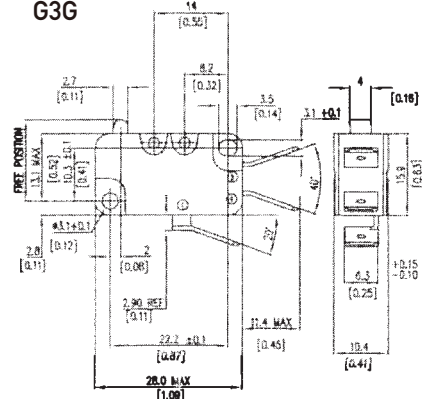

Recommended maximum electrical ratings

	Voltage (max)	Load (A)	Inductive load (A)	Approval
G3M1	250 VAC	7 (0.75 pf)		UL 1054/CSA 22.2 No. 55 - 6,000 operations
	250 VAC	6	2	EN61058-1, T85, 50,000 operations
G3M2	250 VAC	10.1 (0.75 pf)		UL 1054/CSA 22.2 No. 55 - 6,000 operations
	250 VAC	10	3	EN61058-1, T85, 50,000 operations
G3M3	250 VAC	15 (0.75 pf)		UL 1054/CSA 22.2 No. 55 - 6,000 operations
	250 VAC	16	4	EN61058-1, T85, 10,000 operations
G3M4	250 VAC	18 (0.75 pf)		UL 1054/CSA 22.2 No. 55 - 6,000 operations
	250 VAC	18	4	EN61058-1, T85, 10,000 operations
G3G4	250 VAC	10.1 (0.75 pf)		UL 1054/CSA 22.2 No. 55 - 6,000 operations
	250 VAC	10	3	EN61058-1, T85, 10,000 operations

Operating Characteristics

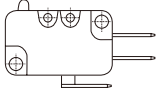
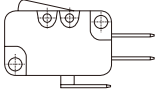
Actuator	Reference	Actuating Force		Release Force		Free Position		Operating Position		Movement Differential		Over travel Maximum	
		Maximum (N)	(ozf)	Minimum (N)	(ozf)	Maximum (mm)	(in)	(mm)	(in)	(mm)	(in)		
 Plain plunger	G3M1..P	0,15	0,54	0,005	0,02	15,9	0,625	14,7 ± 0,3	0,57	$\left. \begin{array}{l} +0,01 \\ -0,001 \end{array} \right\}$	0,2	0,008	*
	G3M2..P	0,70	2,52	0,200	0,72	15,9	0,625	14,7 ± 0,3	0,57		0,2	0,008	
	G3M3..P	1,10	3,96	0,300	1,08	15,9	0,625	14,7 ± 0,3	0,57		0,2	0,008	
	G3M4..P	1,70	6,11	0,500	1,80	15,9	0,625	14,7 ± 0,3	0,57		0,2	0,008	
	G3G4..P	2,70	7,20	0,200	0,72	15,9	0,625	14,5 ± 0,3	0,57		0,5	0,020	
 Ramp plunger	G3M1..R	0,15	0,54	0,005	0,02	15,9	0,625	14,7 ± 0,3	0,57	$\left. \begin{array}{l} +0,01 \\ -0,001 \end{array} \right\}$	0,2	0,008	*
	G3M2..R	0,70	2,52	0,200	0,72	15,9	0,625	14,7 ± 0,3	0,57		0,2	0,008	
	G3M3..R	1,10	3,96	0,300	1,08	15,9	0,625	14,7 ± 0,3	0,57		0,2	0,008	
	G3M4..R	1,70	6,11	0,500	1,80	15,9	0,625	14,7 ± 0,3	0,57		0,2	0,008	
	G3G4..R	2,70	7,20	0,200	0,72	15,9	0,625	14,5 ± 0,3	0,57		0,5	0,020	

* Plunger can be depressed flush with housing. The housing should not be used as an end stop.

Ordering Reference

Basic type	G3	Example: G3 M 1 T1 P C2 UL AU										
Contact gap	M	Microgap										
	G	> 3 mm gap										
Actuating Characteristic	1	0,15										
	2	0,70										
	3	1,10										
	4	1,70	Microgap 2.70	> 3 mm gap								
Terminals	T1	Faston 6.3 × 0.8										
	T2	Faston 4.8 × 0.8										
	T3	Faston 4.8 × 0.5 (microgap only)										
	T4	Solder										
Note:		Microgap - parallel terminals;	> 3 mm gap - flared terminals									
Actuators	P	Plain plunger										
	R	Ramp plunger										
Circuit		No symbol, change-over										
	C2	Normally closed										
	C4	Normally open										
Approvals		No symbol, ENEC										
	UL	UL and CSA										
Contacts		No symbol, silver, silver cadmium oxide										
	AU	Gold plated silver, gold plated silver cadmium oxide										

Table of preferred products

Snap-action Microswitches	Type	Preferred Products	Preferred Products	Page
Subminiature	XC	XCG3Z1 XCG3-J1Z1 XCG3-S1Z1 XCG5Z1 XCG5-J1Z1 XCG5-S1Z1 XCG8Z1 XCG8-81Z1	XCG8-81-J1Z1 XCG8-81-S1Z1 XCF3Z1 XCF3-J1Z1 XCF3-S1Z1 XCG3-U1Z1 XCG4-U1Z1 XCG8-U1Z1	18
	X4	X4F303K1AA X4F305K1AA X4G303K1BB	X4G305K1BB X4C303K1CC X4C305K1CC	23
	V4N	V4NT7UL V4NST7UL V4NSUL V4NT7Y1UL V4NST7Y1UL	V4NSY1UL V4NT7YRUL V4NST7YRUL V4NSYRUL	28
	V4NC	V4NCT7 V4NCT7A1 V4NCT7AR	V4NCS V4NCSA1 V4NCSAR	32
Miniature	XG	XGG2-88Z1 XGG2-88-J23Z1 XGG2-88-J26Z1 XGG2-88-J27Z1 XGG2-88-S20Z1 XGG2-88-S21Z1 XGG3-88Z1 XGG6-88Z1 XGC2-88Z1 XGC2-88-J23Z1 XGC2-88-S20Z1 XGC6-88Z1	XGK2-88Z1 XGK2-88-J26Z1 XGK2-88-S21Z1 XGK3-88Z1 XGK6-88Z1 XG02-88Z1 XG02-88-J27Z1 XG02-88-S20Z1 XG06-88Z1	37
	X3	X3M302K2KA X3M302K2KAJ32 X3M302K2KAJ62 X3M302K2KAT02 X3M303K2KA X3M306K2KA	X3C302K2LB X3C302K2LBJ32 X3C303K2LB X3C306K2LB X3L302K6DD X3L303K6DD	42
	390	393/40/120 393/40/350		47
	340	343/40/75 343/120/350		50
	G3	G3M1T1RULAU G3M1T1PULAU G3M1T1RUL G3M1T1PUL G3M1T2RUL G3M1T2PUL	G3M1T3RUL G3M1T3PUL G3M1T4RUL G3M1T4PUL G3G4T1RUL G3G4T1PUL	54

Headquarters

Johnson Electric Holdings Limited
Johnson Building, 6-22 Dai Shun St, Tai Po Industrial
Estate, New Territories

Hong Kong

Tel: +852 2663 6688

Fax: +852 2897 2054

e-mail: salessupport@johnsonelectric.com

Sales Offices

Asia

Shanghai, China

12/F, Hua Rong Tower
1289 Pudong Road South

Shanghai

200122 China

T +86 21 5882 2880

F +86 21 5882 2800

Tokyo, Japan

Keihin Higashi-Ohi Bldg.
10/F, 2-13-8 Higashi-Ohi

Shinagawa-ku

Tokyo 140-0011 Japan

T +81 3 5762 1031

F +81 3 5762 1032

Seoul, Korea

Misung Bldg B127, 115-7

Nonhyun-Dong, Kangnam-Gu,

Seoul, Korea 135-010

T +82 2 518 8347/8341

F +82 2 518 8342

Singapore

50 Raffles Place #24-02,

Singapore Land Tower

Singapore 048623

T +65 6224 7570

F +65 6224 4538

Europe

Austria

Slovenia, Slovakia, Hungary,

Czech Republic

Linzer Bundesstrasse 101

A-5023 **Salzburg**

T +43 662 88 4910

F +43 662 88 4910 11

France

10 Bld. Louise Michel

F-92230 **Gennevilliers**

T +33 1 46 88 07 70

F +33 1 46 88 07 99

78 Boulevard du 11 Novembre

69003 **Villeurbanne**

T +33 4 37 48 84 60

F +33 4 72 43 90 11

Germany

Sweden, Denmark,

Norway, Finland

Weissenpferd 9

D-58553 **Halver**

T +49 2353 911 0

F +49 2353 911 230

Italy

Via Cadamosto 3

I-20094 Corsico, **Milano**

T +39 02 4869 21

F +39 02 4860 0692

1, Via Vittime di Piazza Fontana

I-10024 **Moncalieri**

T +39 011 68 05 401

F +39 011 68 05 411

Switzerland

Poland, Spain, Turkey, Portugal

Bahnhofstrasse 18

CH-3280 **Murten**

T +41 26 672 71 11

F +41 26 670 19 83

The Netherlands/Belgium

Hanzeweg 12c

NL-2803 **MC Gouda**

T +31 1825 43 154

F +31 1825 43 151

United Kingdom/Ireland

Dukesway

Team Valley Trading Estate

Gateshead

Tyne & Wear NE11 0UB

United Kingdom

T +44 191 401 61 00

F +44 191 401 63 05

Americas

Connecticut

10 Progress Drive, **Shelton**,
CT 06484, USA

T +1 203 447 5362

F +1 203 447 5383

Illinois

3115 N. Wilke Road - Suite C

Arlington Heights,

IL 60004

T +1 847 368 2146

F +1 847 368 2152

Ohio

801 Scholz Drive

Vandalia, OH 45377

T +1 937 454 2345

F +1 937 898 8624

Ontario, Canada

70 Ironside Crescent Unit 7

Scarborough, **Ontario**

M1X 1G4 Canada

T +1 416 299 0852

F +1 416 299 6756

Sao Paulo, Brazil

Av. Papa Joao Paulo I - 1256

CEP 07170-350

Guarulhos **Sao Paulo**, Brazil

T (55) 11-643 156 00

F (55) 11-643 247 11

Johnson Electric Group

Johnson Building, 6-22 Dai Shun Street
Tai Po Industrial Estate, N.T., Hong Kong

Tel: (852) 2663 6688

Fax: (852) 2663 6110

Web Site: www.johnsonelectric.com