

# JOHNSON MOTOR



The data used in this Product Overview may be used as a guideline only. Specific operational characteristics of our products may vary according to individual applications. It is strongly recommended that specific operating conditions are clarified with Johnson Electric before application.

Johnson Electric Terms and Conditions of Sale apply.

All data may be subject to change without notice.

## Johnson Electric Group

---

About Johnson Electric	2
About Johnson Motor	4
Motor Coding System	5
Applications of Johnson Motor	6

## Permanent Magnet DC Motor

---

AG & AT Series	10
HC & HF Series	44
MO Starter Motor Series	132
NC & NF Series	142
PC & SC Series	160
TC Series	176

## High Voltage DC Motor

---

DC Series	180
DF Series	206

## Resource Information

---

Motor Basic	222
Motor Range Characteristics	225
Understanding the Performance Curves	227

## The Johnson Electric Group is one of the world's largest providers of motion actuators for automotive and industrial applications

Over the years, we have shipped billions of motors to more than thirty countries in over one hundred different motor applications. Johnson Electric has an annual production capacity of one billion motors.

to meet all of our commitments and to support our customers' success. Product reliability and assurance of supply are our commitment.

At the heart of Johnson Electric's success is our commitment to make our customers successful. Our customers include many of the world's leading industrial, consumer and automotive companies. We begin by understanding our customers' business needs, and the product application requirements of the end user of our customers' products. Then we design and deliver innovative motion solutions that help our customers to differentiate their products in the marketplace. Our goal is to be instrumental in the successful launch of our customers' products in their respective marketplaces.

### Our Brand Promise

#### Johnson Electric is the most reliable partner

Johnson Electric is responsive and flexible; and has the financial stability and organizational integrity

### Johnson Electric delivers competitive advantage

Johnson Electric delivers differentiation and innovation through its motion products – subsystems comprising of Stepper Motors, DC Motors, AC Motors, Piezo-electric Motors, Switches, Solenoids, Flexi Circuits, Motion Control, Precision Plastics and Precision Gears.

Our business growth hinges with leading "branded" goods producers to deliver differentiation and innovation through our motion products. The core platform for delivering these solutions is a highly developed production base and focused customer support teams throughout the world. This combines scale advantages in production and procurement with skilled and dedicated motion application experts.





**Johnson Electric Holdings Limited is the parent company of the Johnson Electric Group and has been listed on the Stock Exchange of Hong Kong since 1984. The Group structure consists of a number of operating divisions and business units focused on their particular customer application or product segment**

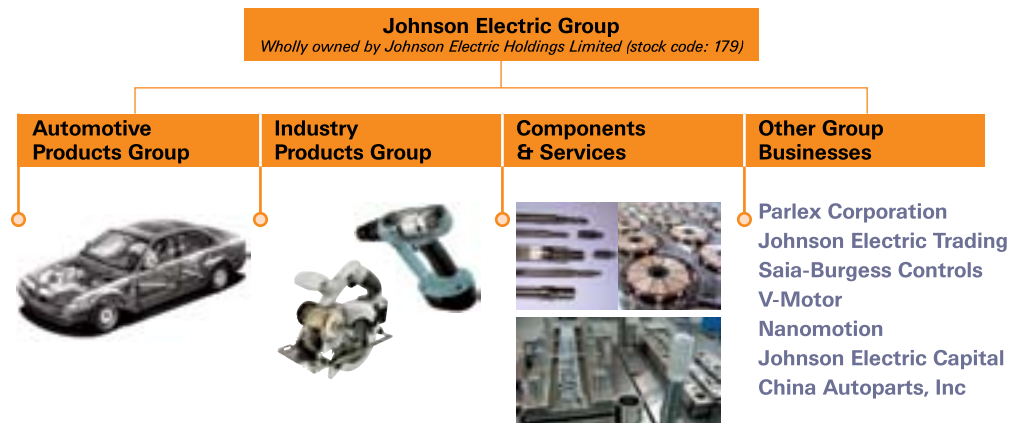

**The Group's motion systems, motors and switches businesses are managed through two primary operating divisions: Automotive Products Group and Industry Products Group.**

The Automotive Products Group, which consists of Johnson Electric's Automotive Motors Group and the Automotive Division of Saia-Burgess Electronics, is focused on providing customized motion solutions for major automotive application segments that include powertrain, body and chassis.

The Industry Products Group is comprised of business units that provide motion products and solutions for various commercial and industrial application sectors, including home appliances, power tools, business equipment, personal care products, medical equipment and healthcare, building automation and security, audio-visual and other industrial products.

Supporting these two operating divisions is the Group's Components & Services function which produces metal and plastic parts, tooling and production equipment for motor and motion related products. Johnson Electric is a highly vertically integrated business that manufactures an exceptionally wide range of components that form the basis for its final assembled end products. We make magnets, bearings, shafts, housings, laminations, commutators and die cast parts. We also build tools, assembly fixtures, plastic molds as well as armature winding and other production machines.

In addition to motion systems and motors, the Group also consists of a number of complementary manufacturing businesses and other subsidiary companies. These include an innovative provider of flexible printed circuits and interconnect solutions; a successful niche player in the programmable controls industry; and a rapidly growing specialty metals and trading services company.

# Johnson Motor

---

With a capacity of 3 million motors a day, Johnson Motor is the #1 motor brand for DC and AC motors used in automotive, power tools, home appliances, business equipment, personal care and audio-visual markets.

Johnson Motor combines motor and component technology with application expertise, scale and production efficiency.



Value-added assemblies eliminate added cost to maintain multiple vendors, added manufacturing resources and additional inventory. Whether it's as simple as adding a special connector or a modifying a shaft, or as complex as fabricating a complete assembly of motors or solenoids, gears, switches and electronic controls; Johnson Electric is capable and willing to work with our customers' design teams to come up with cost effective motion solutions.

We appreciate the opportunity to collaboratively work with our customers' design teams early on the development cycle of the applications. We can respond to requirements quickly by networking our know-how across the global Johnson Electric organization and at the same time providing local support to increase efficiency, reduce costs and to streamline application development cycles.

## PMDC Motor Code (Marking)

### 1 - Special Feature (Series):

- D - High Voltage
- H - Heavy Duty
- K - Spade Terminal 90°
- P - Plastic Magnet
- Q - High Energies Magnet
- S - Low Noise

### 2 - Motor Shape:

- C - Round Motor
- F - Flat sided

### 3 - Motor Frame Size:

from 0...9 & B - 000, 1000-1000 series

### 4 - Brush Configuration:

- 0 - Metal finger leaf
- 1 - Carbon leaf
- 2 - Flip-Flop Carbon Leaf (side terminal)
- 3 - Flip-Flop Carbon Leaf
- 4 - Plug-In female

### 4 - Brush Configuration:

- 5 - Brush Cage (inside)
- 6 - Brush Cage (outside)
- 7 - Brush Cage in die-cast metal endcap
- 8 - Carbon leaf in die-cast metal endcap

### 5 - Armature No. of Poles/bars:

3 / 5 / 7 / 8 / 1(2)

### 6 - Motor & Magnet Length:

- no letter - standard version
- M - Medium length
- L - Long version
- S - short
- XL - Extra Long

### 7- Magnet Length Code

### 8 - Lamination Material

- no letter - cold rolled steel
- G - Electrical Steel

**1 2 3 4 5 6 7 8**  
**D C 7 8 1 L S G**

**Motor Series No.**

**MO 30 SM**  
**1 2 3**

### 1 - Product Type

- MO : Motor
- SH : Shaft
- AT : Armature
- BR : Brushes Motor

### 2 - Diameter (Unit in Inches)

- 20 : 2.0"
- 25 : 2.5"
- 28 : 2.8"
- 30 : 3.0"

### 3 - Typical Application

- SM : Starter Motor
- WF/WJ : Wiper Motor
- MM : Miscellaneous Motor

Typical Applications & Motor Series	Permanet Magnet Direct Curret (PMDC) Motor																															
	AG-M04	AT-M06	AT-M07	AT-M08	AT-M10	AT-M12	AT-M14	AT-M21	AT-M28	HC203DG	HC213LG	HC313G	HC313MG	HC315G	HC315MG	HC315MSG	HC385G	HC385MG	HC385XLG	HC485G	HC485XLLG	HC610G	HC613G	HC615G	HC615SG	HC683G	HC683LG	HC683LP	HC683XLLG	HC685LG	HC785LP	
<b>Medical Equipment &amp; Healthcare</b>																																
Blood Pressure Pump					●	●	●																									
<b>Building Automation &amp; Security</b>																																
Surveillance Camera					●	●																										
Motorised Blinds																							●									
<b>Business Machines</b>																																
Card Reader					●	●		●																								
Printer								●									●	●	●	●											●	
Projector								●																								
Optical Disk Drive			●	●		●																										
Scanner																				●												
<b>Leisure &amp; Fitness</b>																																
All Terrain Vehicle																																
Jet Ski																																
Outboard Marine																																
Ride-on Car																											●	●				
Snow Mobile																																
Toys	●	●	●	●	●	●																										
<b>Power &amp; Garden Tools</b>																																
Circular Saw																																
Drill																											●		●			
Hedge Trimmer																																
Impact Driver																																
Lawn Mower																																
Reciprocal Saw																																
Rotary Tool																																
Screwdriver													●	●																		●
<b>Consumer Electronics</b>																																
Camcorder																																
Camera	●	●	●	●	●	●	●	●																								
Car CD/DVD					●	●																										
CD/DVD Player			●	●		●				●																						
Game Controller																																
MD Player																																
Portable MD Player	●		●																													
Portable CD/DVD Player																																
Joystick																									●							●
<b>Home Appliances</b>																																
Coffee Machine																																
Sewing Machine																																
Stand Mixer																																
<b>White Goods</b>																																
Dishwasher																																
Refrigerator																																
<b>Personal Care</b>																																
Bathroom Accessories									●																							
Foot Bath																																
Hair Clipper																																
Hair Curler												●																				
Hair Dryer																											●					
Hair Trimmer																																
Stick Massager													●																			
Toilet Lid Opener								●																								
Toothbrush																																
<b>Floor Care</b>																																
Brush Roll																																
Hand Vacuum																																
Power Brush																																
<b>Distribution</b>	●	●	●	●	●	●	●	●				●		●	●																	●
<b>Page Number</b>	10	12	14	18	24	32	36	40	44	46	48	50	52	58	66	68	74	80	86	88	90	94	96	98	100	104	106	108	110	116		





# PMDC Motors

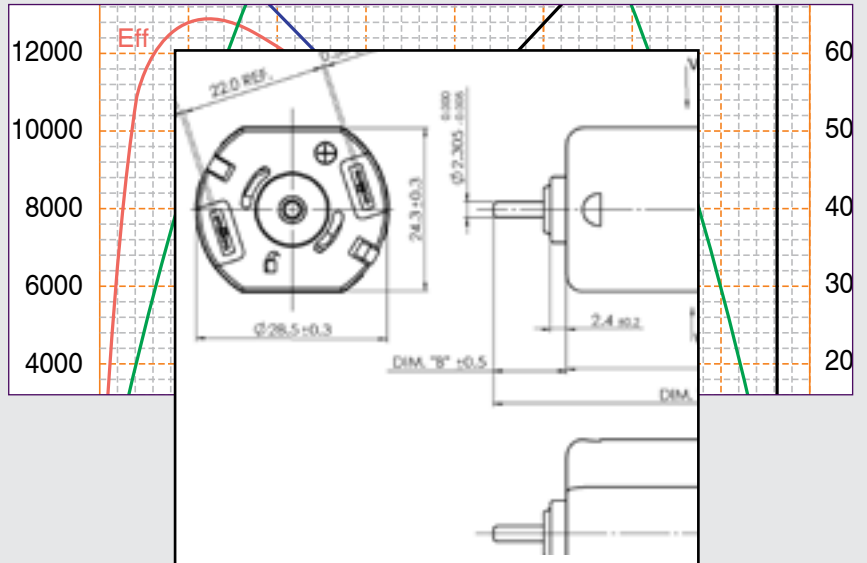

## Market

Consumer Electronics, Leisure & Fitness

## Application:

Portable MD Player , Camera,



This compact motor can be used in portable MD player lift, camera auto focus, and various optical, audio equipment and toys

## Motor Characteristics:

Diameter	: 4.6 mm
Length	: 12.5 mm
Flat	: 3.4 mm
Shaft Diameter	: 0.6 mm
Weight	: 0.6 g
Nominal Voltage	: 1.5 V
Torque Constant	: 0.251 m-Nm/A
Dynamic Resistance	: 7.87 Ohms
Motor Regulations	: 629167 Rpm/m-Nm
Pole Number	: 3

## Standard Data:

Operating Temperature	: -10 — 50°C
Storage Temperature	: -20 — 100°C
Mounting	: Any position
Electrical Connection	: Terminal
Standards	: RoHS

## Electrical Performance:

	No Load	Stall	Max Eff
Speed (Rpm)	30220		20100
Current (A)	0.052	0.191	0.098
Torque (mNm)		0.05	0.016
Efficiency (%)			22.87



Drawing:

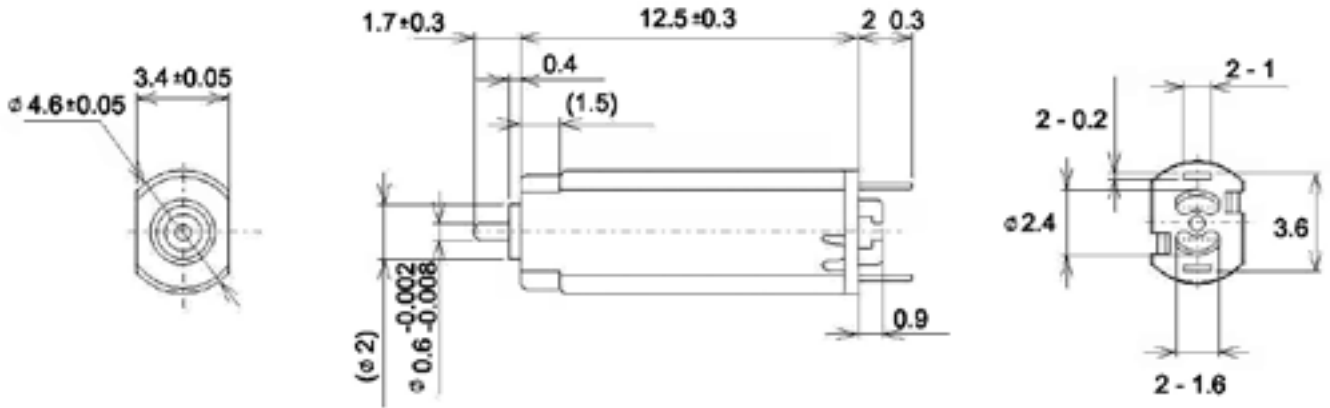

Unit in mm

Performance Data:

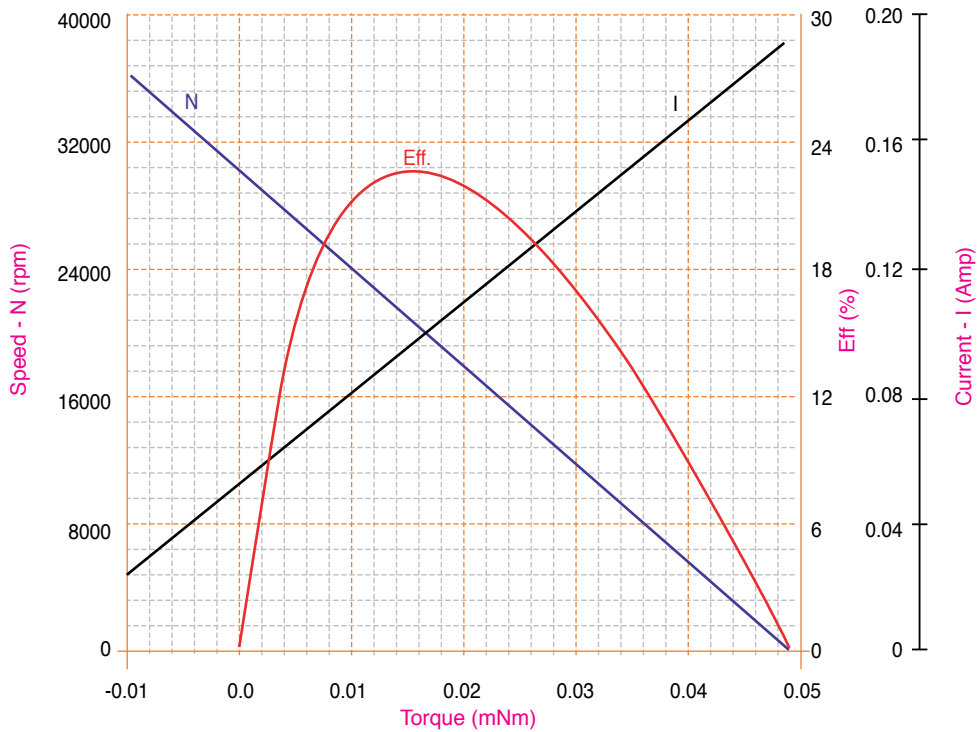

## Market

Consumer Electronics, Leisure & Fitness

## Application:

Camera,



This compact motor can be used in camera auto focus and various optical equipment and toys

## Motor Characteristics:

Diameter	: 6 mm
Length	: 9 mm
Flat	: 5 mm
Shaft Diameter	: 0.8 mm
Weight	: 0.8 g
Nominal Voltage	: 1.8 V
Torque Constant	: 0.307 m-Nm/A
Dynamic Resistance	: 3.18 Ohms
Motor Regulations	: 243678 Rpm/m-Nm
Pole Number	: 3

## Standard Data:

Operating Temperature	: -10 — 50°C
Storage Temperature	: -20 — 100°C
Mounting	: Any position
Electrical Connection	: Terminal
Standards	: RoHS

## Electrical Performance:

	No Load	Stall	Max Eff	Max Power
Speed (Rpm)	42400		31350	21170
Current (A)	0.072	0.566	0.20	0.319
Torque (mNm)		0.17	0.045	0.087
Efficiency (%)			41.40	
Power (W)				0.193

## Drawing:

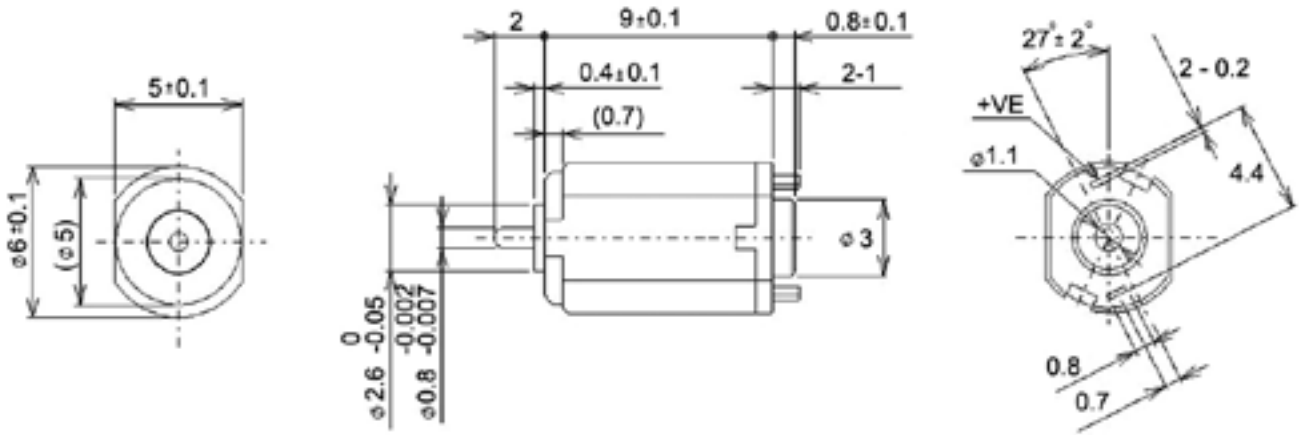

Unit in mm

## Performance Data:

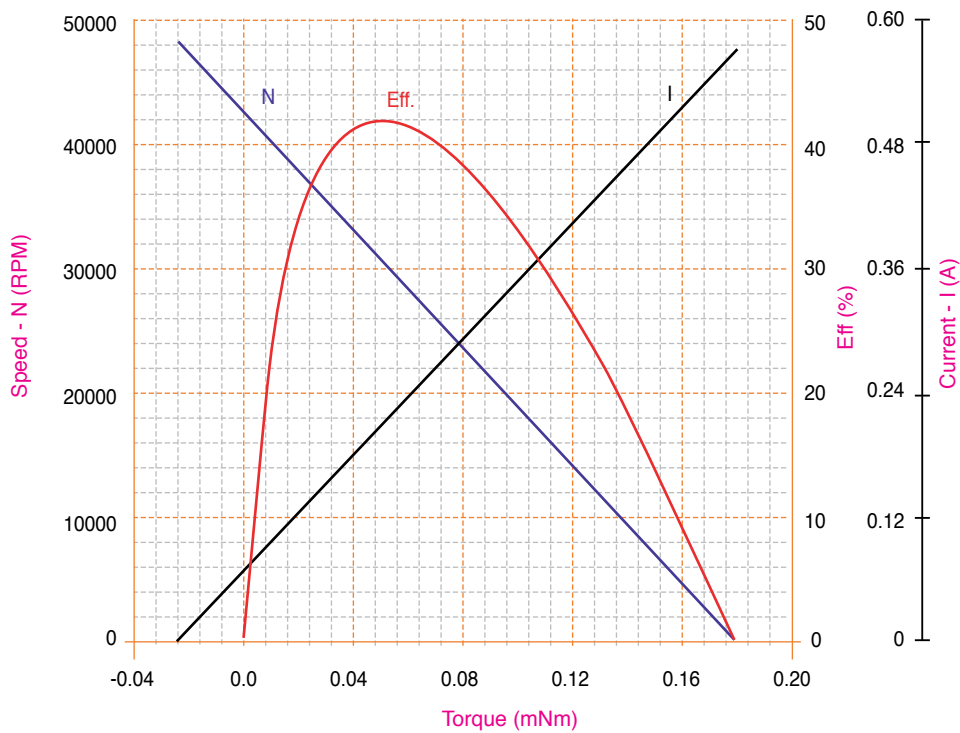

## Market

Consumer Electronics, Business Machines,  
Leisure & Fitness

## Application:

Portable MD Player, Optical Disk Drive, Camera,



This compact motor can be used in portable MD player lift, optical disk drive loading, camera auto focus, and various audio, optical equipment and toys

## Motor Characteristics:

Diameter	: 6.8 mm
Length	: 10 mm
Flat	: 4.5 mm
Shaft Diameter	: 0.8 mm
Weight	: 1.0 g
Nominal Voltage	: 2.5 V
Torque Constant	: 0.518 m-Nm/A
Dynamic Resistance	: 17.73 Ohms
Motor Regulations	: 301136 Rpm/m-Nm
Pole Number	: 3

## Standard Data:

Operating Temperature	: -10 — 50°C
Storage Temperature	: -20 — 100°C
Mounting	: Any position
Electrical Connection	: Terminal
Standards	: RoHS

## Electrical Performance:

	No Load	Stall	Max Eff
Speed (Rpm)	26500		17590
Current (A)	0.041	0.17	0.084
Torque (mNm)		0.09	0.29
Efficiency (%)			25.9

## Drawing:

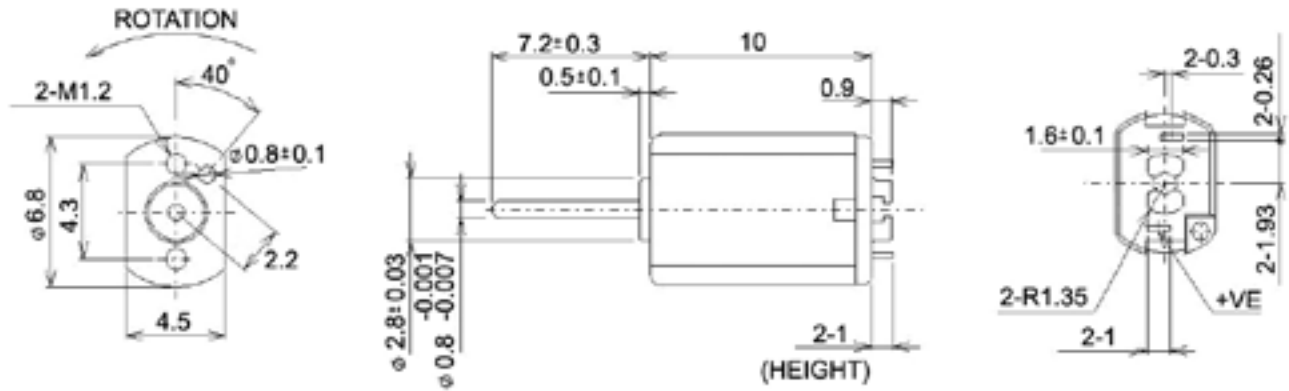

Unit in mm

## Performance Data:

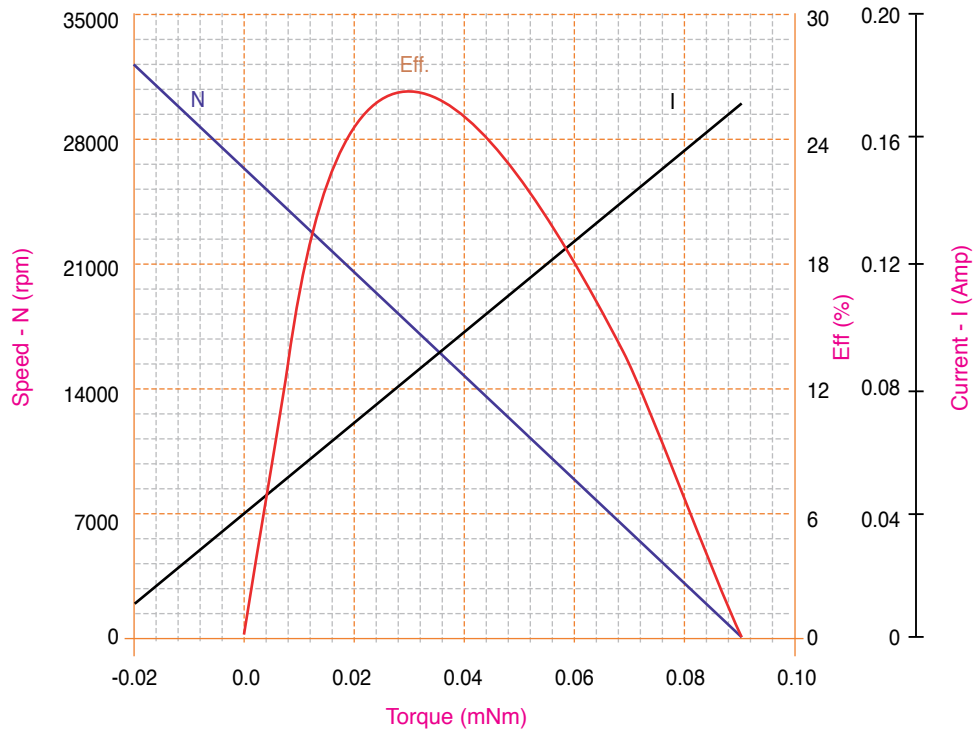

## Market

Consumer Electronics, Business Machines,  
Leisure & Fitness

## Application:

CD & DVD Player, Toys, Optical Disk



This compact motor can be used in CD & DVD player feed, optical disk drive feed, and various audio, optical equipment and toys

## Motor Characteristics:

Diameter	: 7 mm
Length	: 20 mm
Flat	: 4.7 mm
Shaft Diameter	: 0.8 mm
Weight	: 2.6 g
Nominal Voltage	: 3 V
Torque Constant	: 0.887 m-Nm/A
Dynamic Resistance	: 6.5 Ohms
Motor Regulations	: 60976 Rpm/m-Nm
Pole Number	: 3

## Standard Data:

Operating Temperature	: -10 — 50°C
Storage Temperature	: -20 — 100°C
Mounting	: Any position
Electrical Connection	: Terminal
Standards	: RoHS

## Electrical Performance:

	No Load	Stall	Max Eff	Max Power
Speed (Rpm)	25000		18570	12820
Current (A)	0.055	0.462	0.159	0.253
Torque (mNm)		0.41	0.105	0.205
Efficiency (%)			42.89	
Power (W)				0.275

## Drawing:

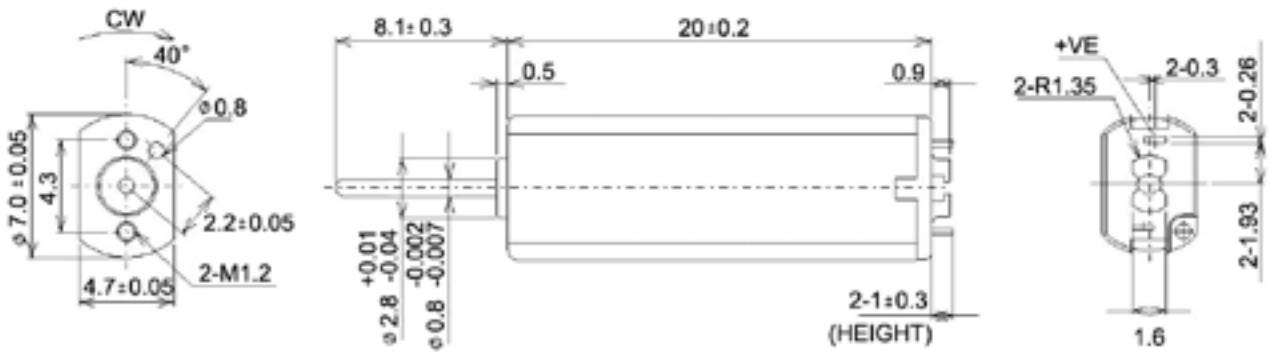

Unit in mm

## Performance Data:

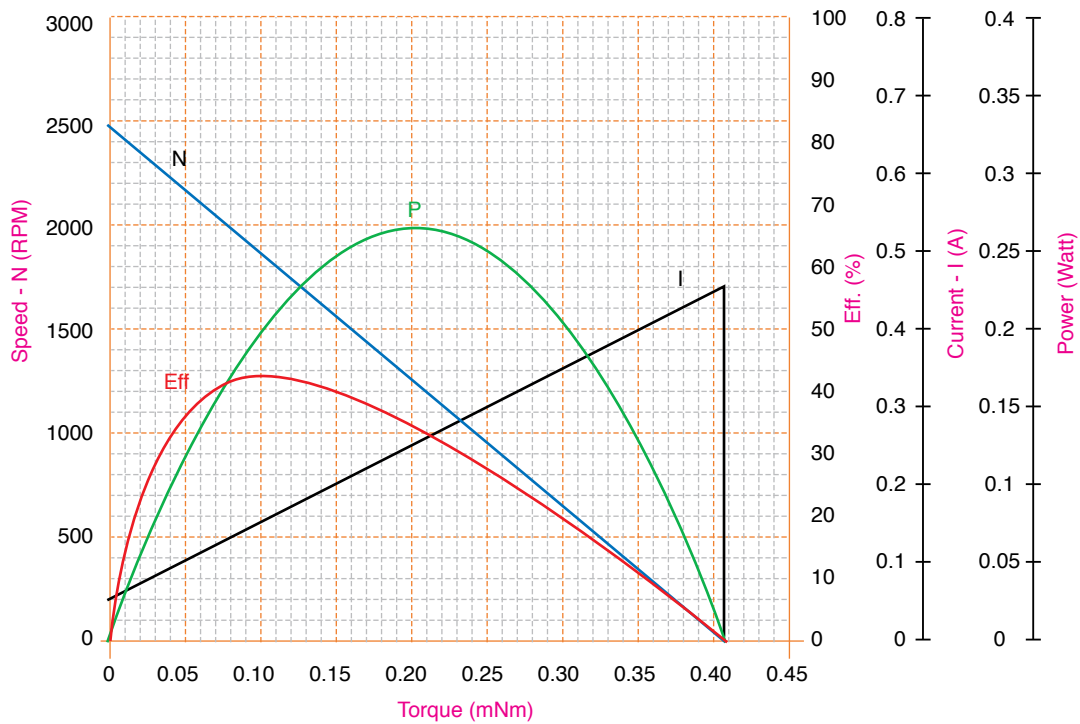

## Market

Consumer Electronics, Business Machines,  
Leisure & Fitness

## Application:

Optical Disk Drive, Camera,



This compact motor can be used in optical disk drive loading, camera lens barrier, and various optical equipment and toys

## Motor Characteristics:

Diameter	: 8 mm
Length	: 10 mm
Flat	: 6 mm
Shaft Diameter	: 1 mm
Weight	: 1.4 g
Nominal Voltage	: 5 V
Torque Constant	: 1.241 m-Nm/A
Dynamic Resistance	: 28.69 Ohms
Motor Regulations	: 112500 Rpm/m-Nm
Pole Number	: 3

## Standard Data:

Operating Temperature	: -10 — 50°C
Storage Temperature	: -20 — 100°C
Mounting	: Any position
Electrical Connection	: Terminal
Standards	: RoHS

## Electrical Performance:

	No Load	Stall	Max Eff	Max Power
Speed (Rpm)	24300		16860	12240
Current (A)	0.036	0.174	0.078	0.104
Torque (mNm)		0.22	0.065	0.108
Efficiency (%)			29.71	
Power (W)				0.138



Drawing:

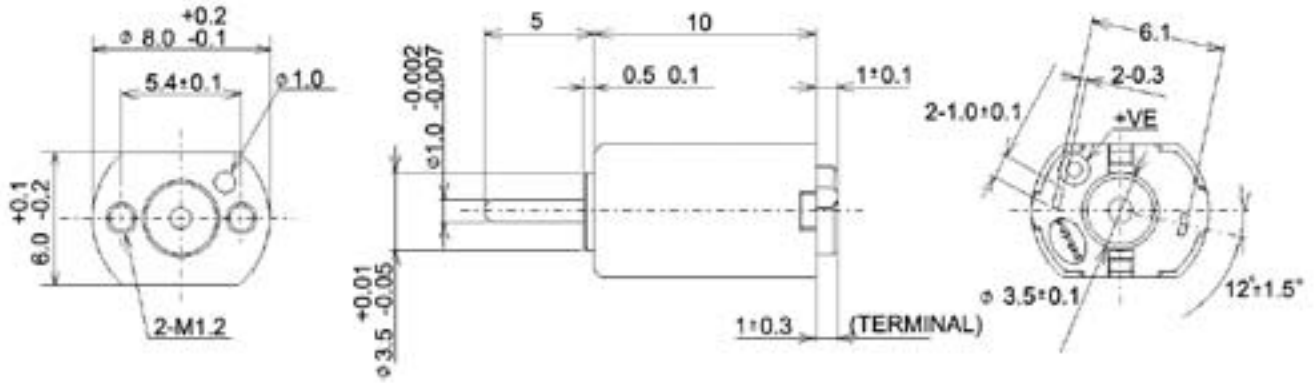

Unit in mm

Performance Data:

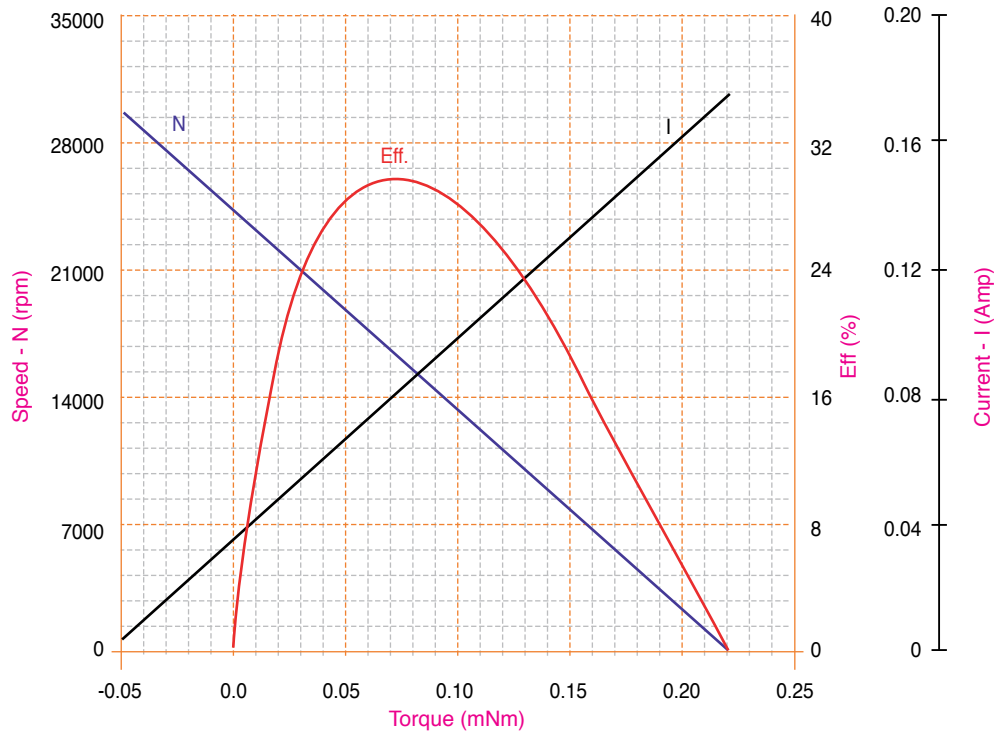

## Market

Consumer Electronics, Business Machines

## Application:

Optical Disk Drive, CD & DVD Player,  
DVD & CD-ROM



This compact motor can be used for sled function of various optical and audio-visual equipment

## Motor Characteristics:

Diameter	: 8 mm
Length	: 20 mm
Flat	: 6 mm
Shaft Diameter	: 1 mm
Weight	: 3.6 g
Nominal Voltage	: 3 V
Torque Constant	: 1.683 m-Nm/A
Dynamic Resistance	: 7.73 Ohms
Motor Regulations	: 21440 Rpm/m-Nm
Pole Number	: 3

## Standard Data:

Operating Temperature	: -10 — 50°C
Storage Temperature	: -20 — 100°C
Mounting	: Any position
Electrical Connection	: Terminal
Standards	: RoHS

## Electrical Performance:

	No Load	Stall	Max Eff
Speed (Rpm)	14000		10800
Current (A)	0.036	0.388	0.117
Torque (mNm)		0.653	0.150
Efficiency (%)			48.35

## Drawing:

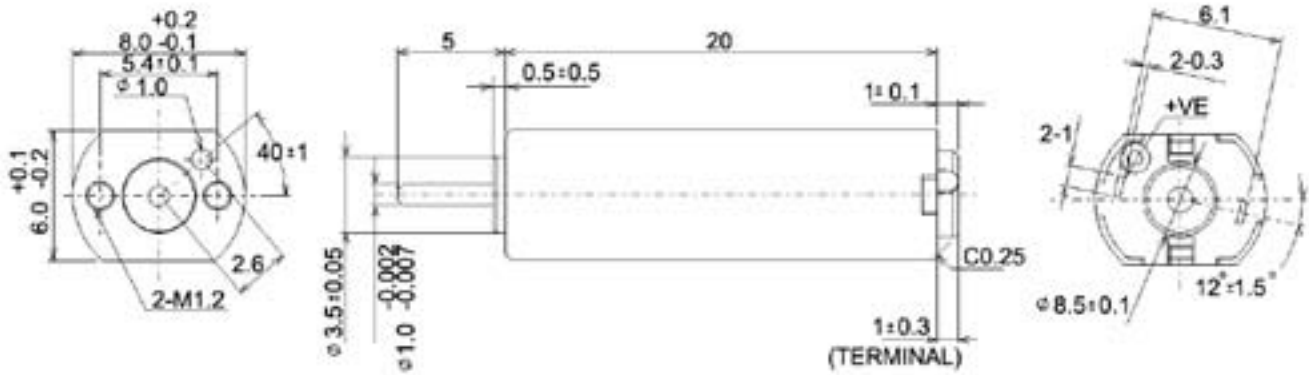

Unit in mm

## Performance Data:

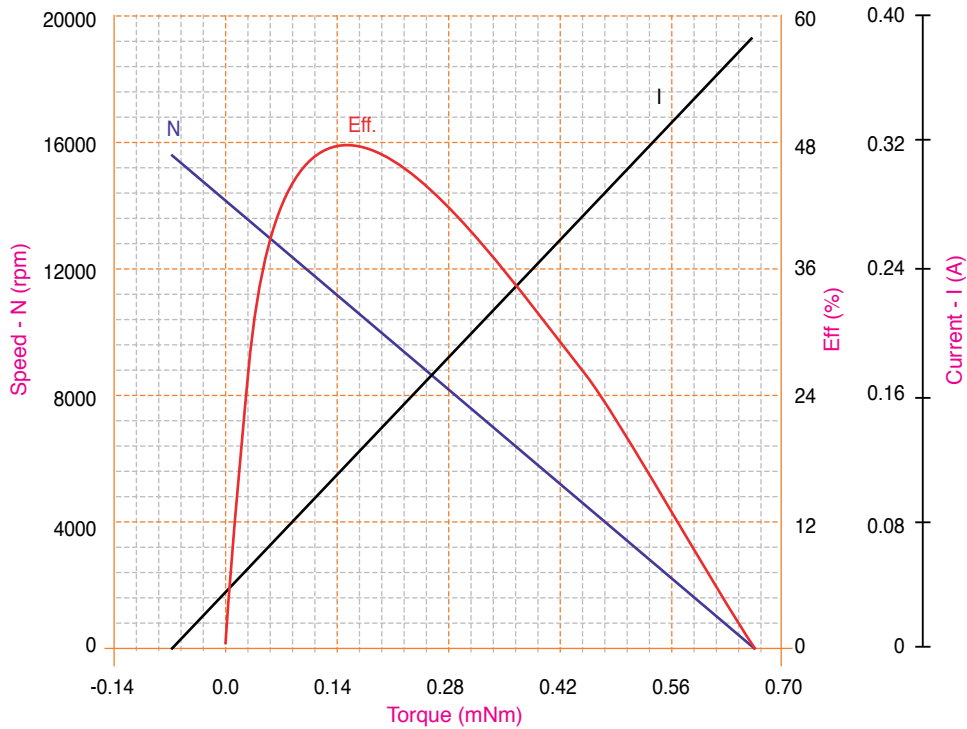

## Market

Consumer Electronics, Business Machines

## Application:

Optical Disk Drive, CD & DVD Player,  
DVD & CD-ROM



This compact motor can be used in the sled application of various optical and audio equipment.

## Motor Characteristics:

Diameter	: 8 mm
Length	: 14.5 mm
Flat	: 6 mm
Shaft Diameter	: 0.8 mm
Weight	: 2.4 g
Nominal Voltage	: 4.5 V
Torque Constant	: 1.778 m-Nm/A
Dynamic Resistance	: 10.287 Ohms
Motor Regulations	: 31047.619 Rpm/m-Nm
Pole Number	: 3

## Standard Data:

Operating Temperature	: -10 — 50°C
Storage Temperature	: -20 — 100°C
Mounting	: Any position
Electrical Connection	: Terminal
Standards	: RoHS

## Electrical Performance:

	No Load	Stall	Max Eff	Max Power
Speed (Rpm)	22480		17809	11240
Current (A)	0.030	0.437	0.115	0.234
Torque (mNm)		0.724	0.150	0.362
Efficiency (%)			54.36	
Power (W)			0.281	0.426

## Drawing:

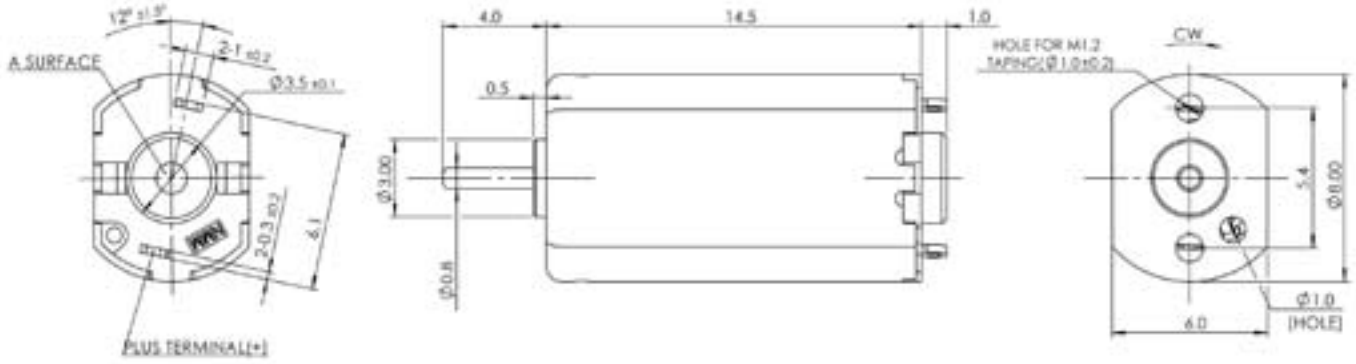

Unit in mm

## Performance Data:

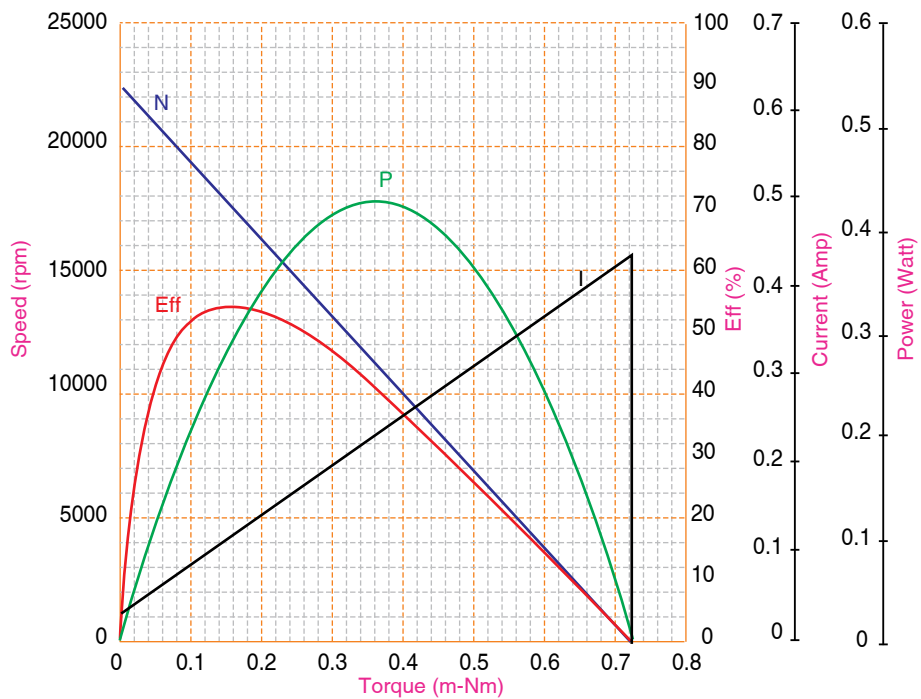

## Market

Consumer Electronics, Healthcare & Medical  
Equipment, Leisure & Fitness, Building Automation & Security

## Application:

Toys, Blood Pressure Pump, Card Reader, Surveillance Camera,  
Interchangeable Lens, Camera



This compact motor can be used in camera strobe & zoom, and various optical and personal equipment.

## Motor Characteristics:

Diameter	: 10 mm
Length	: 11 mm
Flat	: 8 mm
Shaft Diameter	: 1 mm
Weight	: 2.6 g
Nominal Voltage	: 3 V
Torque Constant	: 0.831 m-Nm/A
Dynamic Resistance	: 5.18 Ohms
Motor Regulations	: 56133 Rpm/m-Nm
Pole Number	: 3

## Standard Data:

Operating Temperature	: -10 — 50°C
Storage Temperature	: -20 — 100°C
Mounting	: Any position
Electrical Connection	: Terminal
Standards	: RoHS

## Electrical Performance:

	No Load	Stall	Max Eff	Max Power
Speed (Rpm)	27000		20140	13660
Current (A)	0.067	0.579	0.197	0.320
Torque (mNm)		0.48	0.122	0.24
Efficiency (%)			43.54	
Power (W)				0.343

## Drawing:

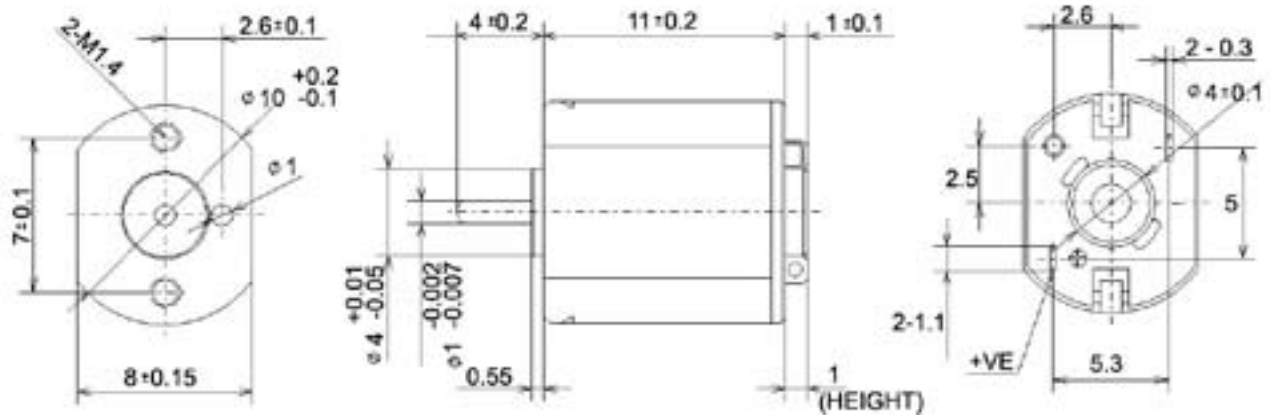

Unit in mm

## Performance Data:

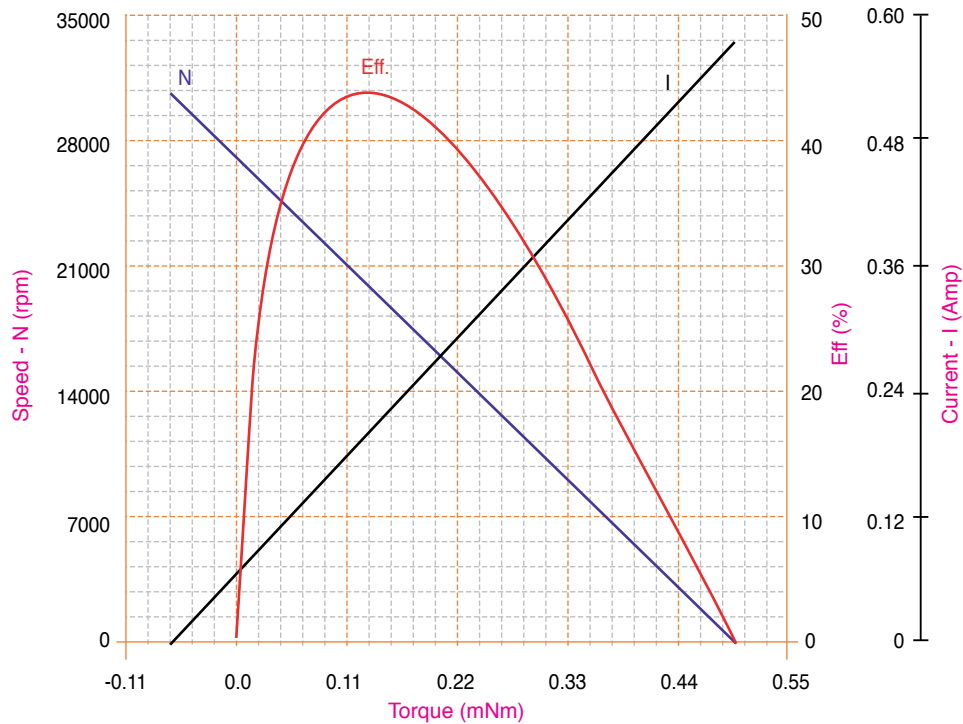

## Market

Consumer Electronics, Healthcare & Medical  
Equipment, Leisure & Fitness, Building Automation & Security

## Application:

Surveillance Camera, Blood Pressure Pump,  
Toys, Camera



This compact motor can be used in camera zoom and various optical and personal equipment.

## Motor Characteristics:

Diameter	: 10 mm
Length	: 12.5 mm
Flat	: 8 mm
Shaft Diameter	: 1.0 mm
Weight	: 3.2 g
Nominal Voltage	: 2.8 V
Torque Constant	: 1.952 m-Nm/A
Dynamic Resistance	: 12.352 Ohms
Motor Regulations	: 30897.959 Rpm/m-Nm
Pole Number	: 3

## Standard Data:

Operating Temperature	: -10 — 50°C
Storage Temperature	: -20 — 100°C
Mounting	: Any position
Electrical Connection	: Terminal
Standards	: RoHS

## Electrical Performance:

	No Load	Stall	Max Eff	Max Power
Speed (Rpm)	12033		8937	6017
Current (A)	0.027	0.227	0.079	0.127
Torque (mNm)		0.389	0.100	0.195
Efficiency (%)			42.67	
Power (W)			0.09	0.123



## Drawing:

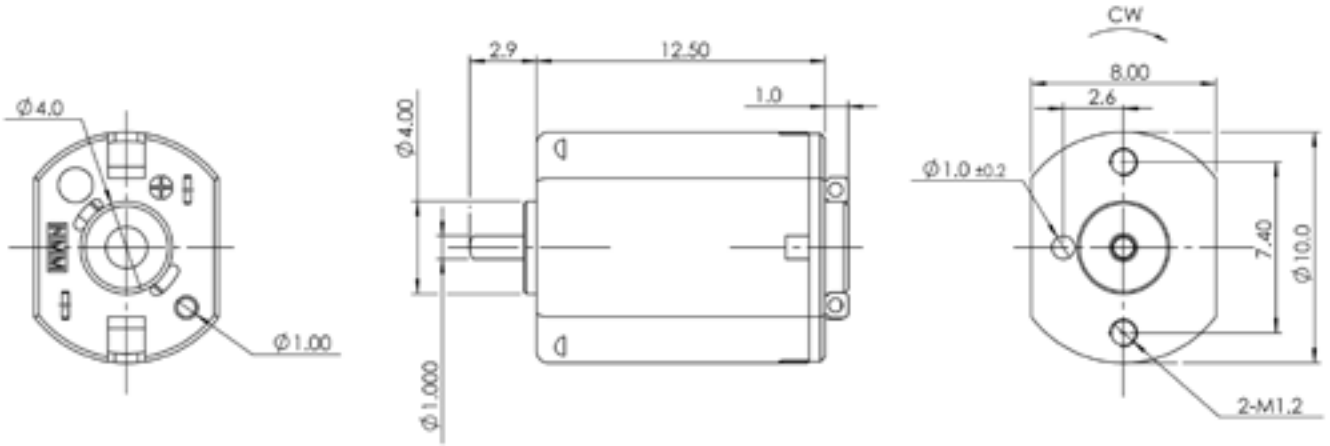

Unit in mm

## Performance Data:

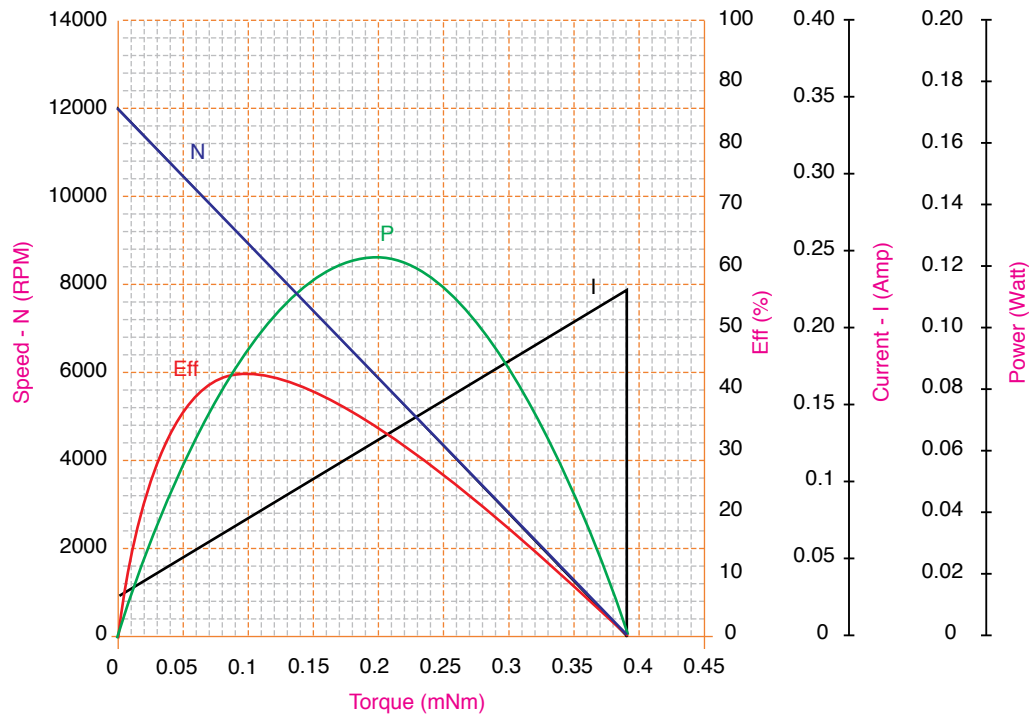

## Market

Consumer Electronics, Building Automation & Security, Healthcare & Medical Equipment

## Application:

Camera Zoom, Surveillance Camera, Car CD Feed, Blood Pressure Pump



This compact motor can be used in camera zoom, car CD feed, and various optical and personal equipment.

## Motor Characteristics:

Diameter	: 10 mm
Length	: 20 mm
Flat	: 8 mm
Shaft Diameter	: 1 mm
Weight	: 5.6 g
Nominal Voltage	: 2.5 V
Torque Constant	: 1.516 m-Nm/A
Dynamic Resistance	: 2.66 Ohms
Motor Regulations	: 9684 Rpm/m-Nm
Pole Number	: 3

## Standard Data:

Operating Temperature	: -10 — 50°C
Storage Temperature	: -20 — 100°C
Mounting	: Any position
Electrical Connection	: Terminal
Standards	: RoHS

## Electrical Performance:

	No Load	Stall	Max Eff	Max Power
Speed (Rpm)	13800		11060	7060
Current (A)	0.059	0.94	0.234	0.489
Torque (mNm)		1.425	0.283	0.713
Efficiency (%)			56.20	
Power (W)				0.527



## Market

Consumer Electronics

## Application:

CD/DVD Player



Designed for audio loading application

## Motor Characteristics:

Diameter	: 10 mm
Length	: 15 mm
Flat	: 8 mm
Shaft Diameter	: 1 mm
Weight	: 3.8 g
Nominal Voltage	: 2 V
Torque Constant	: 1.806 m-Nm/A
Dynamic Resistance	: 5.531 Ohms
Motor Regulations	: 16173.469 Rpm/m-Nm
Pole Number	: 3

## Standard Data:

Operating Temperature	: -10 — 50°C
Storage Temperature	: -20 — 100°C
Mounting	: Any position
Electrical Connection	: Terminal
Standards	: RoHS

## Electrical Performance:

	No Load	Stall	Max Eff	Max Power
Speed (Rpm)	9600		7373	4800
Current (A)	0.06	0.45	0.109	0.197
Torque (mNm)		0.47	0.138	0.297
Efficiency (%)			48.69	
Power (W)			0.106	0.149



## Market

Healthcare & Medical Equipment, Leisure & Fitness, Building Automation & Security, Consumer Electronics, Business Machines

## Application:

Blood Pressure Pump, Toys, Card Reader, DVD & Car CD Player, Optical Disk Drive, Surveillance Camera



This versatile & compact motor can be used in DVD and car CD player loading, optical disk drive sled, and various audio-visual, personal equipment and toys

## Motor Characteristics:

Diameter	: 12 mm
Length	: 15 mm
Flat	: 10 mm
Shaft Diameter	: 1 mm
Weight	: 5.2 g
Nominal Voltage	: 3 V
Torque Constant	: 2.562 m-Nm/A
Dynamic Resistance	: 9.74 Ohms
Motor Regulations	: 11660 Rpm/m-Nm
Pole Number	: 3

## Standard Data:

Operating Temperature	: -10 — 50°C
Storage Temperature	: -20 — 100°C
Mounting	: Any position
Electrical Connection	: Terminal
Standards	: RoHS

## Electrical Performance:

	No Load	Stall	Max Eff	Max Power
Speed (Rpm)	9200		7050	4650
Current (A)	0.029	0.308	0.094	0.167
Torque (mNm)		0.79	0.184	0.395
Efficiency (%)			48.05	
Power (W)				0.192

## Drawing:

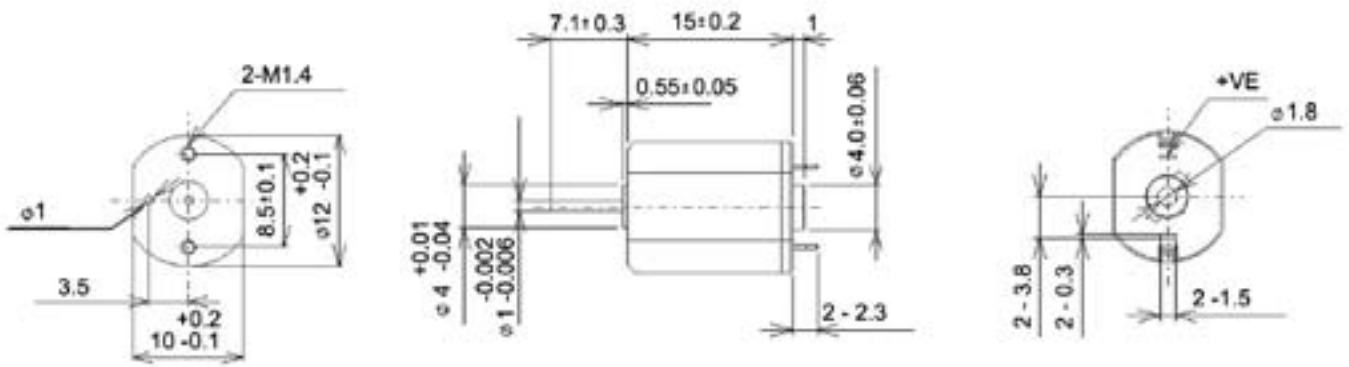

Unit in mm

## Performance Data:

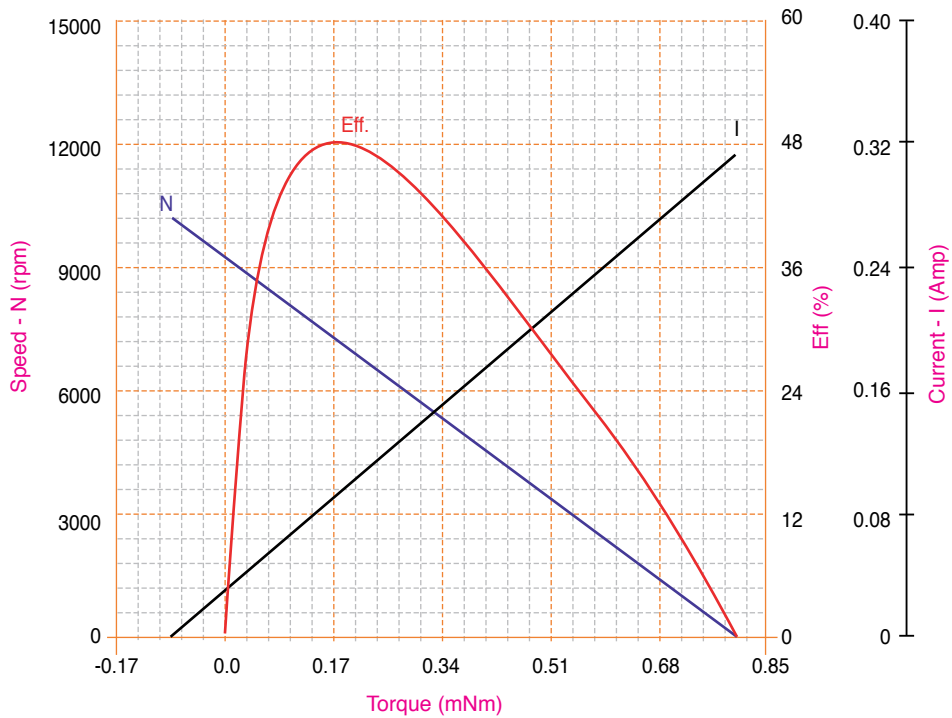

## Market

Consumer Electronics, Leisure & Fitness

## Application:

Camera, Toys, Car CD Player



This compact motor can be used in camera zoom, car CD player, loading/sled functions, and various optical, audio-visual equipment and toys

## Motor Characteristics:

Diameter	: 12 mm
Length	: 20 mm
Flat	: 10 mm
Shaft Diameter	: 1 mm
Weight	: 7.6 g
Nominal Voltage	: 5 V
Torque Constant	: 2.691 m-Nm/A
Dynamic Resistance	: 4.9 Ohms
Motor Regulations	: 5974 Rpm/m-Nm
Pole Number	: 3

## Standard Data:

Operating Temperature	: -10 — 50°C
Storage Temperature	: -20 — 100°C
Mounting	: Any position
Electrical Connection	: Terminal
Standards	: RoHS

## Electrical Performance:

	No Load	Stall	Max Eff	Max Power
Speed (Rpm)	16400		13680	8270
Current (A)	0.039	2.75	0.202	0.526
Torque (mNm)		1.020	0.454	1.373
Efficiency (%)			64.32	
Power (W)				1.189



## Drawing:

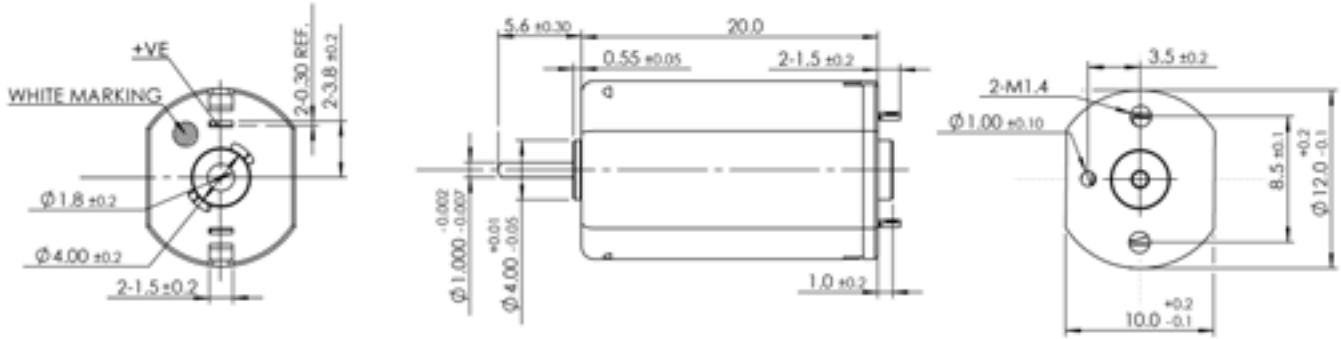

Unit in mm

## Performance Data:

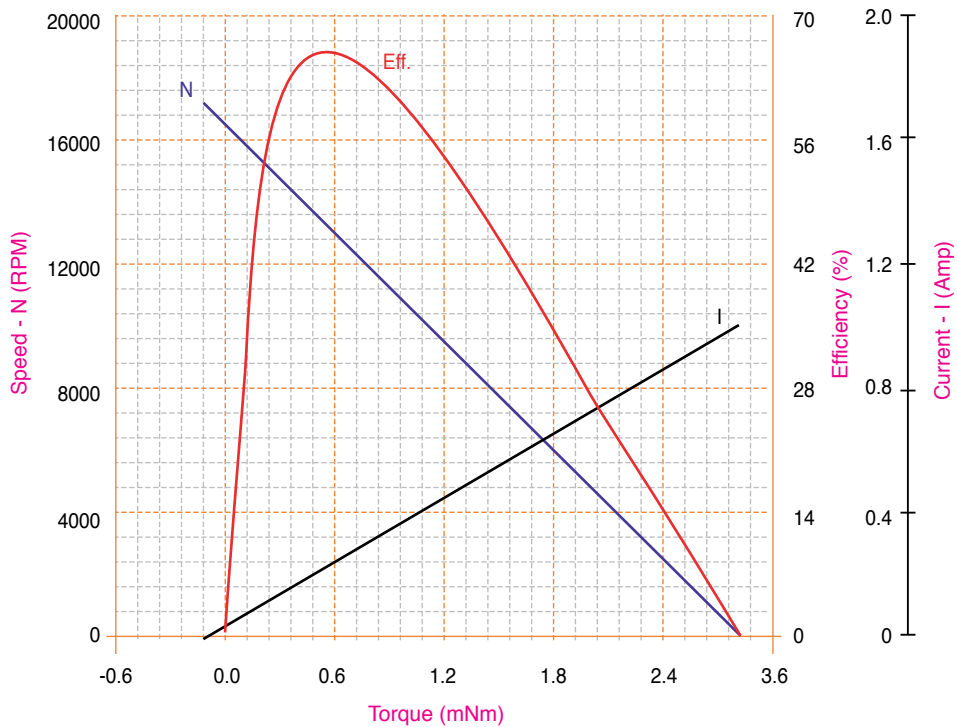

## Market

Consumer Electronics, Healthcare & Medical Equipment

## Application:

Camera, Blood Pressure Pump



This compact motor can be used in various optical and healthcare devices

## Motor Characteristics:

Diameter	: 14 mm
Length	: 20 mm
Flat	: 12 mm
Shaft Diameter	: 1.5 mm
Weight	: 9.8 g
Nominal Voltage	: 3 V
Torque Constant	: 2.935 m-Nm/A
Dynamic Resistance	: 4.98 Ohms
Motor Regulations	: 4810 Rpm/m-Nm
Pole Number	: 3

## Standard Data:

Operating Temperature	: -10 — 50°C
Storage Temperature	: -20 — 100°C
Mounting	: Any position
Electrical Connection	: Terminal
Standards	: RoHS

## Electrical Performance:

	No Load	Stall	Max Eff	Max Power
Speed (Rpm)	8500		6750	4290
Current (A)	0.04	0.602	0.155	0.318
Torque (mNm)		1.77	0.363	0.884
Efficiency (%)			55.09	
Power (W)				0.397

## Drawing:

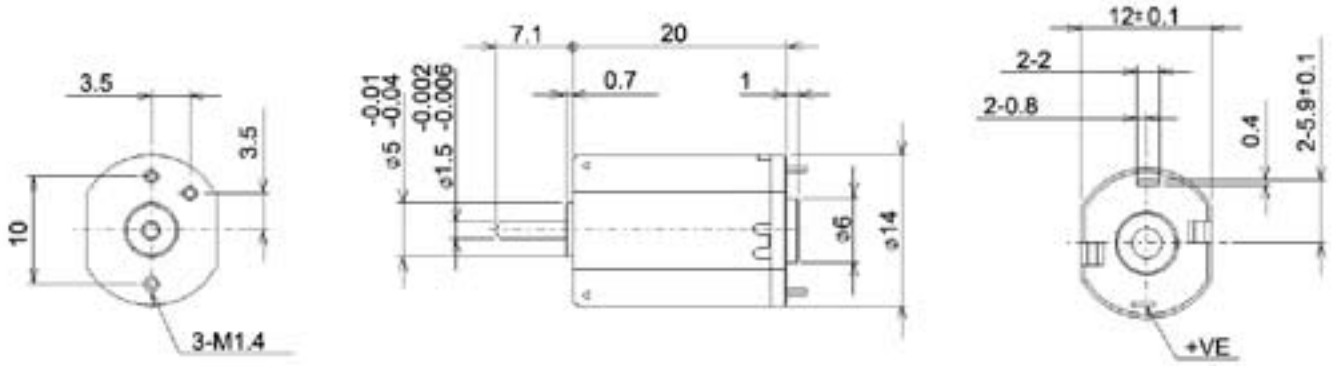

Unit in mm

## Performance Data:

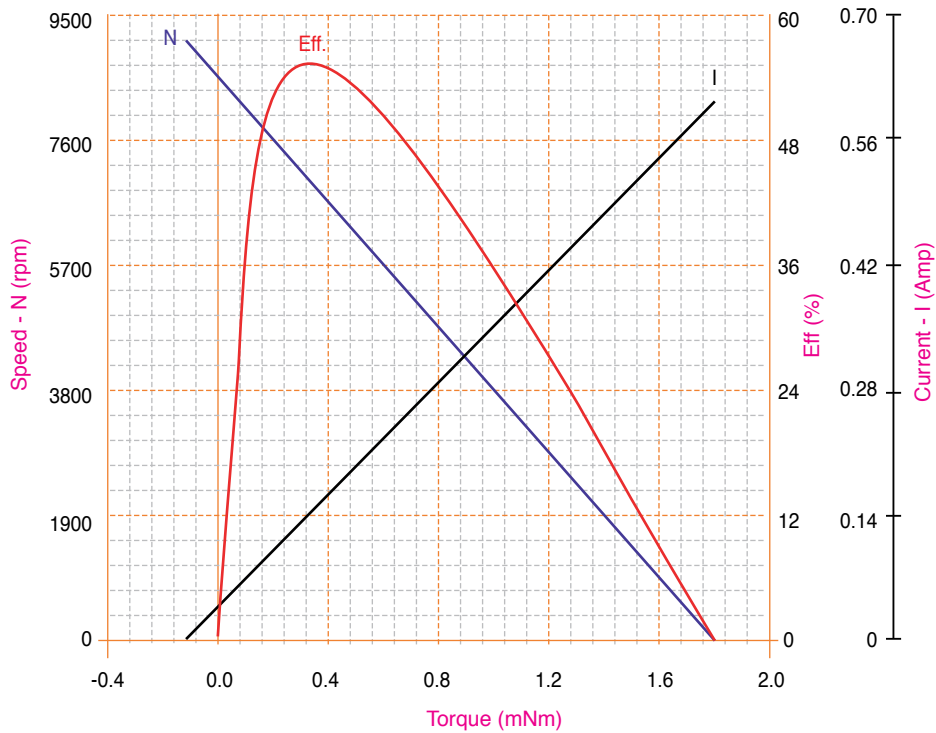

## Market

Business Machines, Consumer Electronics,  
Personal Care

## Application:

Projector, Interchangeable Lens, Card Reader, Toilet Seat



This compact motor can be used in various optical equipment as well as toilet lid openers

## Motor Characteristics:

Diameter	: 21 mm
Length	: 24 mm
Flat	: 16.6 mm
Shaft Diameter	: 1.2 mm
Weight	: 26 g
Nominal Voltage	: 22.8 V
Torque Constant	: 16.204 m-Nm/A
Dynamic Resistance	: 34.76 Ohms
Motor Regulations	: 1129 Rpm/m-Nm
Pole Number	: 3

## Standard Data:

Operating Temperature	: -10 — 50°C
Storage Temperature	: -20 — 100°C
Mounting	: Any position
Electrical Connection	: Terminal
Standards	: RoHS

## Electrical Performance:

	No Load	Stall	Max Eff	Max Power
Speed (Rpm)	12000		9850	6100
Current (A)	0.031	0.656	0.143	0.336
Torque (mNm)		10.63	1.933	5.315
Efficiency (%)			61.25	
Power (W)				3.395

## Drawing:

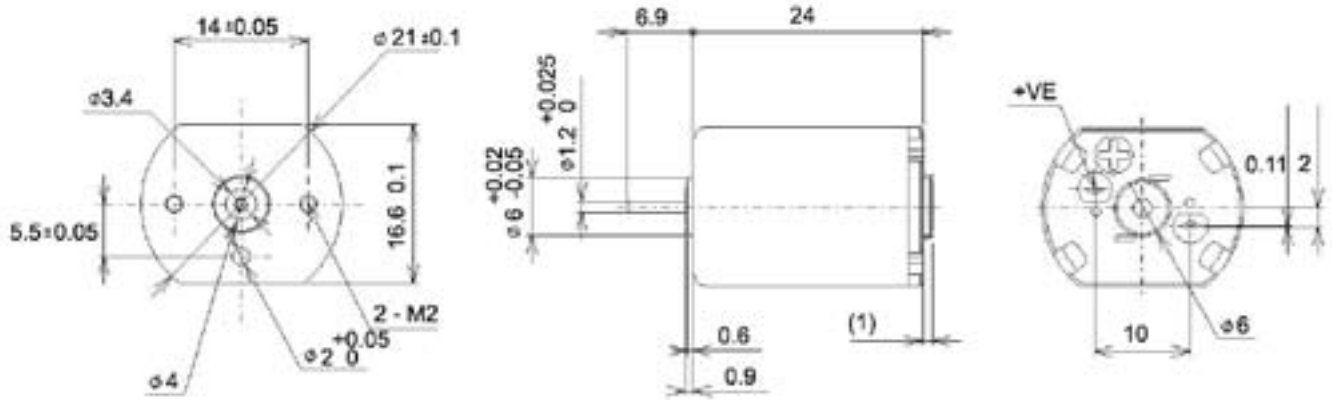

Unit in mm

## Performance Data:

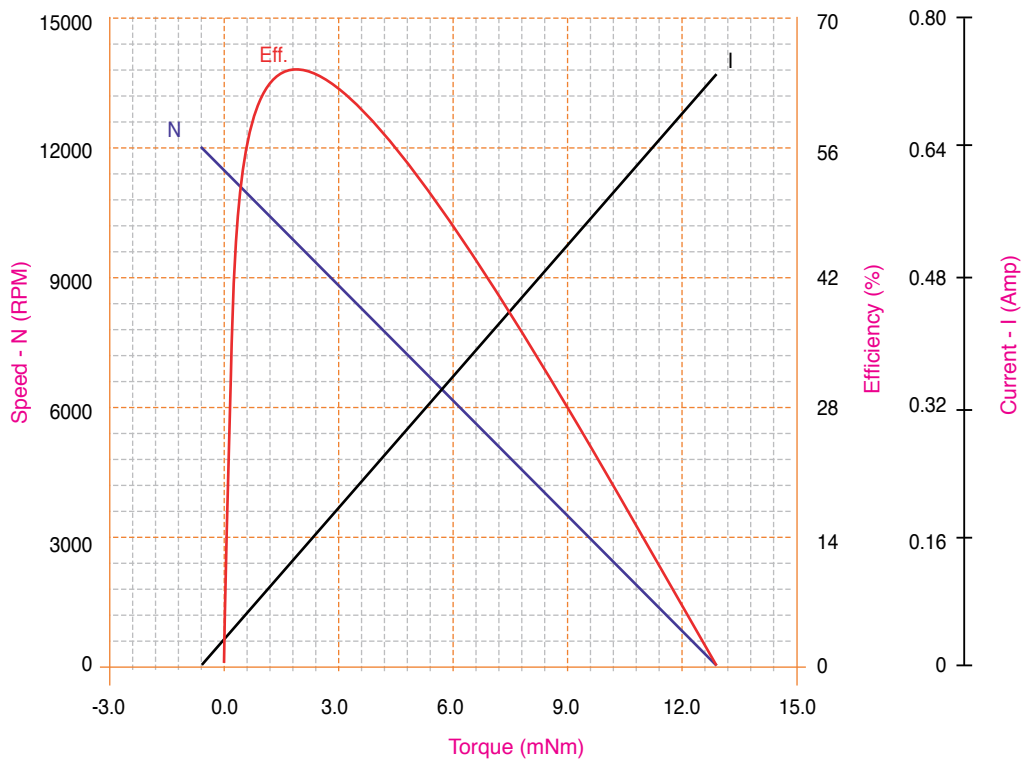

## Market

Personal Care

## Application:

Bathroom Accessories



## Motor Characteristics:

Diameter	: 28 mm
Length	: 45 mm
Flat	: 25 mm
Shaft Diameter	: 2 mm
Weight	: 103.6 g
Nominal Voltage	: 22.8 V
Torque Constant	: 38.058 m-Nm/A
Dynamic Resistance	: 23.672 Ohms
Motor Regulations	: 150.765 Rpm/m-Nm
Pole Number	: 5

## Standard Data:

Operating Temperature	: -10 — 50°C
Storage Temperature	: -20 — 100°C
Mounting	: Any position
Electrical Connection	: Female Terminal
Standards	: RoHS

## Electrical Performance:

	No Load	Stall	Max Eff	Max Power
Speed (Rpm)	5360		4567	2680
Current (A)	0.029	0.963	0.167	0.496
Torque (mNm)		35.552	5.257	17.776
Efficiency (%)			66.01	
Power (W)			2.515	4.991

## Drawing:

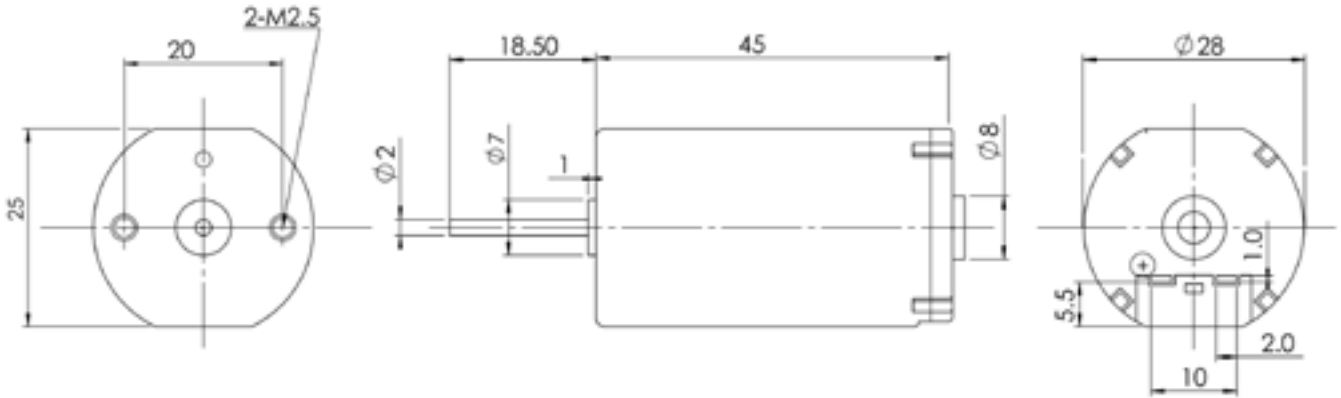

Unit in mm

## Performance Data:



## Market

Personal Care

## Application:

Bathroom Accessories



## Motor Characteristics:

Diameter	: 28 mm
Length	: 40 mm
Flat	: 25 mm
Shaft Diameter	: 2 mm
Weight	: 88 g
Nominal Voltage	: 22.8 V
Torque Constant	: 40 m-Nm/A
Dynamic Resistance	: 28.099 Ohms
Motor Regulations	: 175.765 Rpm/m-Nm
Pole Number	: 5

## Standard Data:

Operating Temperature	: -10 — 50°C
Storage Temperature	: -20 — 100°C
Mounting	: Any position
Electrical Connection	: Female Terminal
Standards	: RoHS

## Electrical Performance:

	No Load	Stall	Max Eff	Max Power
Speed (Rpm)	5536		4724	2768
Current (A)	0.024	0.811	0.140	0.418
Torque (mNm)		31.497	4.622	15.748
Efficiency (%)			71.89	
Power (W)			2.287	4.567



## Drawing:

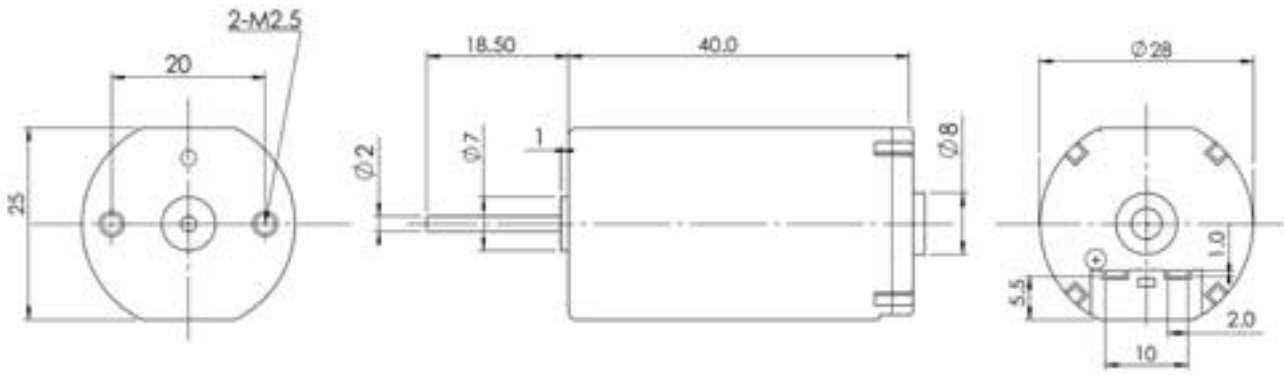

Unit in mm

## Performance Data:

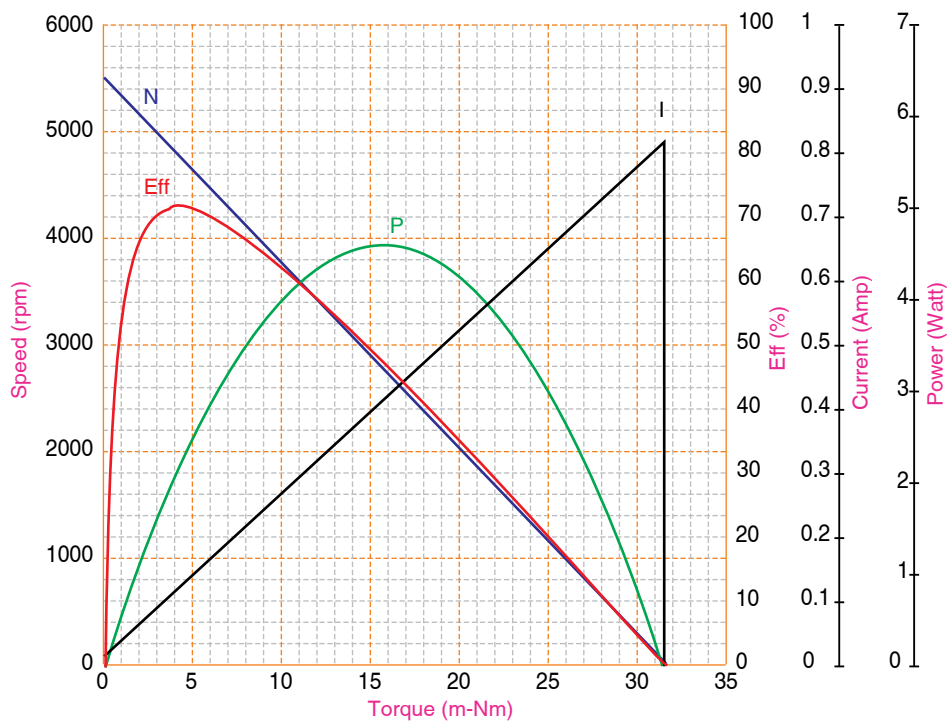

## Market

Consumer Electronics

## Application:

CD / VCD / DVD Player



This motor can be used in DVD, VCD and CD Player. It allows DVD spindle application to have a higher torque, smooth cogging to achieve a shorter spin up/down time. Turntables are supplied to equip the motors with total spindle solution.

## Motor Characteristics:

Diameter	: 24.4 mm
Length	: 12.3 mm
Shaft Diameter	: 2 mm
Weight	: 23.6 g
Nominal Voltage	: 3 V
Torque Constant	: 7.745 m-Nm/A
Dynamic Resistance	: 7.713 Ohms
Motor Regulations	: 1224.143 Rpm/m-Nm
Pole Number	: 3

## Standard Data:

Operating Temperature	: -10 — 50°C
Storage Temperature	: -20 — 100°C
Mounting	: Any position
Electrical Connection	: Connector
Standards	: RoHS

## Electrical Performance:

	No Load	Stall	Max Eff	Max Power
Speed (Rpm)	3527		2917	1764
Current (A)	0.017	0.389	0.081	0.203
Torque (mNm)		2.881	0.498	1.441
Efficiency (%)			62.56	
Power (W)			0.152	0.266

## Drawing:

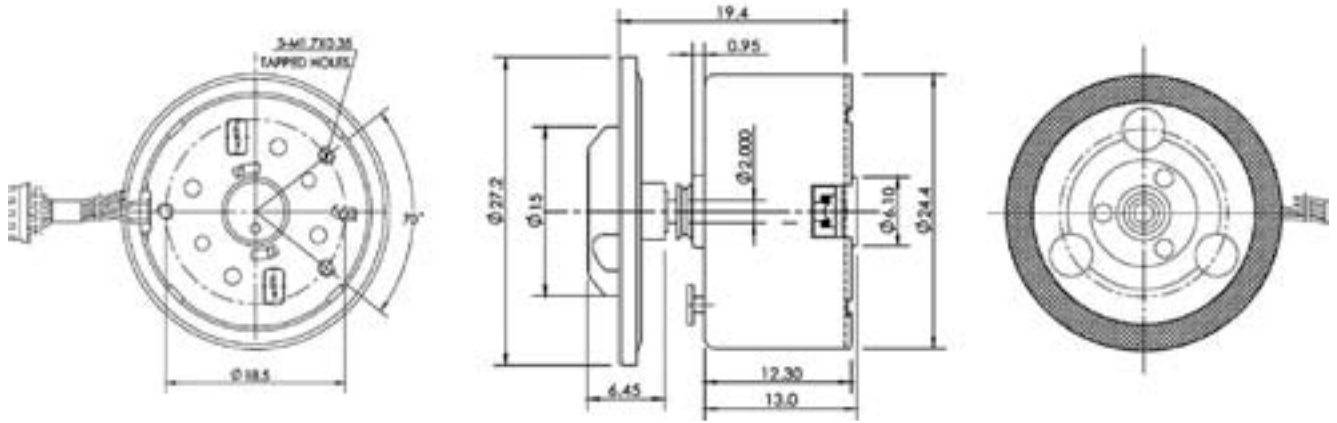

Unit in mm

PMDC

## Performance Data:

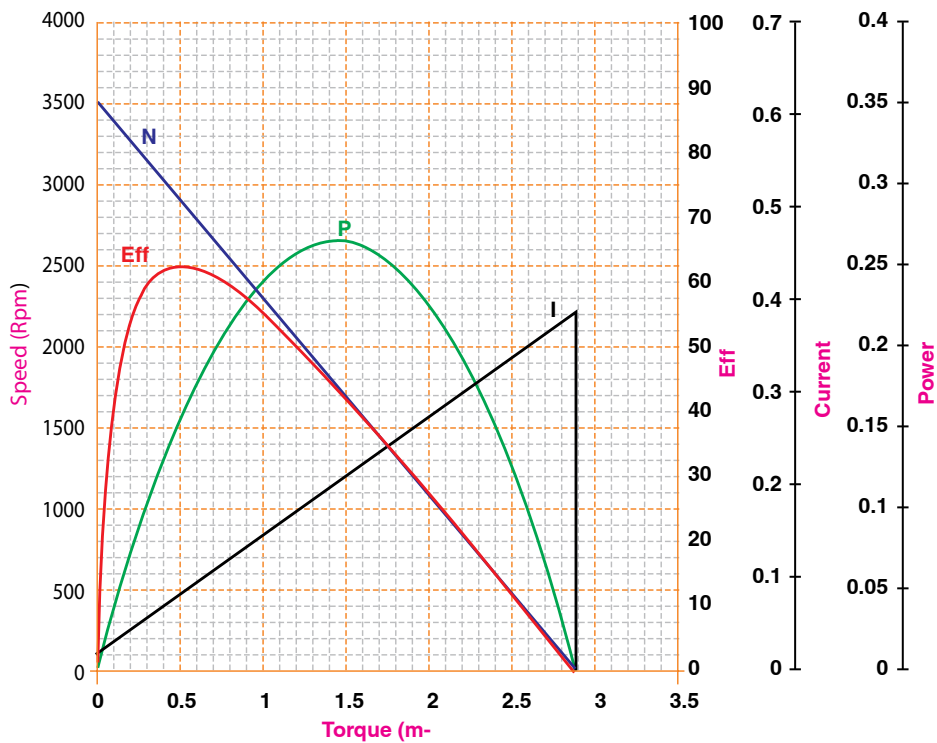

## Market

Personal Care

## Application:

Hair Curler

## Motor Characteristics:

Diameter	: 24.2 mm
Length	: 30.5 mm
Shaft Diameter	: 2 mm
Weight	: 45.4 g
Nominal Voltage	: 21 V
Torque Constant	: 5.105 m-Nm/A
Dynamic Resistance	: 2.43 Ohms
Motor Regulations	: 781.463 Rpm/m-Nm
Pole Number	: 3



Specially designed motor for high power hair curler

## Standard Data:

Operation Temperature	: -10 — 50°C
Storage Temperature	: -20 — 100°C
Mounting	: Any position
Electrical Connection	: Terminal
Winding Temperature (Tmax)	: 180 °C
Direction of Rotation	: CCW
Standards	: UL, CSA
Remarks	: Varistor

## Electrical Performance:

	No Load	Stall	Max Eff	Max Power
Speed (Rpm)	31090		25824	15545
Current (A)	0.32	7.67	1.56	4.00
Torque (mNm)		44.11	7.47	22.05
Efficiency (%)			61.51	
Power (W)			20.20	35.90



## Market

Personal Care

## Application:

Stick Massager

## Motor Characteristics:

Diameter	: 27.5 mm
Length	: 32.5 mm
Shaft Diameter	: 2.305 mm
Weight	: 50.6 g
Nominal Voltage	: 24 V
Torque Constant	: 32.279 m-Nm/A
Dynamic Resistance	: 32.185 Ohms
Motor Regulations	: 304.857 Rpm/m-Nm
Pole Number	: 3



The most widely-used motor for stick massagers

## Standard Data:

Operation Temperature	: -10 — 50°C
Storage Temperature	: -20 — 100°C
Mounting	: Any position
Electrical Connection	: Terminal
Winding Temperature (Tmax)	: 180 °C
Direction of Rotation	: CCW
Standards	: UL, CSA

## Electrical Performance:

	No Load	Stall	Max Eff	Max Power
Speed (Rpm)	6900		5500	3400
Current (A)	0.048	0.746	0.189	0.397
Torque (mNm)		22.53	4.55	11.27
Efficiency (%)			57.72	
Power (W)			2.612	4.054

## Drawing:

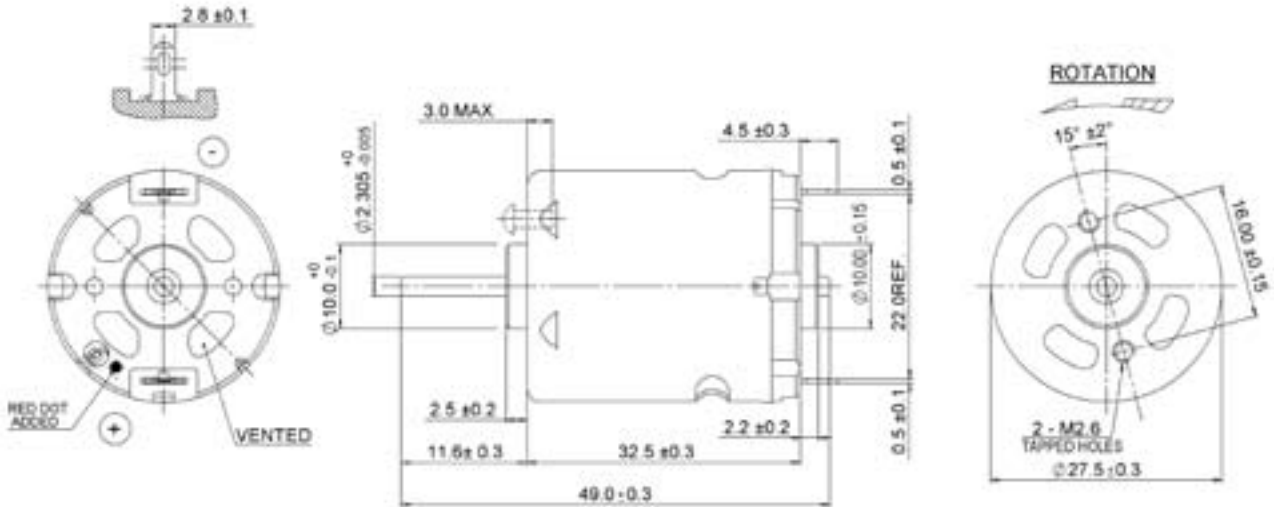

Unit in mm

## Performance Data:

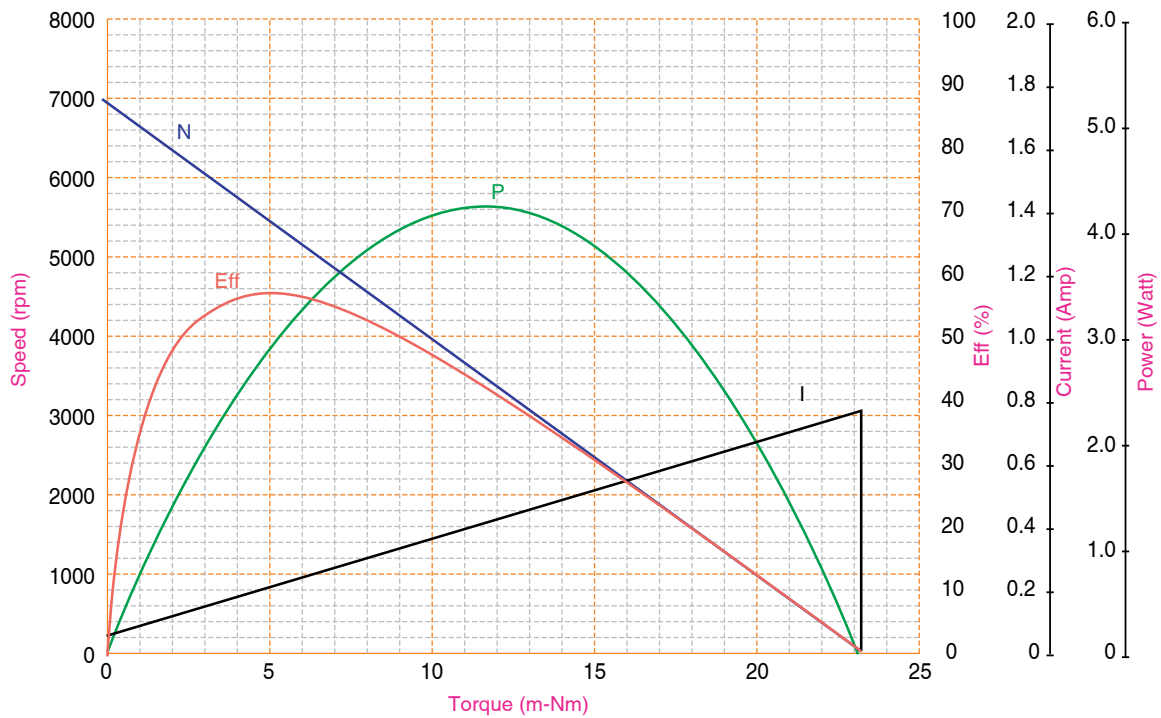

## Market

Power & Garden  
Tools

## Application:

Screw Driver

## Motor Characteristics:

Diameter	: 27.5 mm
Length	: 38 mm
Shaft Diameter	: 2.305 mm
Weight	: 72 g
Nominal Voltage	: 3.6 V
Torque Constant	: 2.579 m-Nm/A
Dynamic Resistance	: 0.12 Ohms
Motor Regulations	: 169.417 Rpm/m-Nm
Pole Number	: 3

## Standard Data:

Operation Temperature	: -10 — 50°C
Storage Temperature	: -20 — 100°C
Mounting	: Any position
Electrical Connection	: Terminal
Power Consumption	: 19.12 W
Power Output	: 12.76 W
Running Torque	: 11.27 mNm
Direction of Rotation	: CCW
Standard	: RoHS

## Electrical Performance:

	No Load	Stall	Max Eff	Max Power
Speed (Rpm)	12800		10900	6400
Current (A)	0.94	30.10	5.08	15.48
Torque (mNm)		75.10	10.89	37.71
Efficiency (%)			68.20	
Output Power (W)			12.48	25.23



This #300 series high speed motor is compact, efficient and satisfies the application needs for long running time and power



## Drawing:

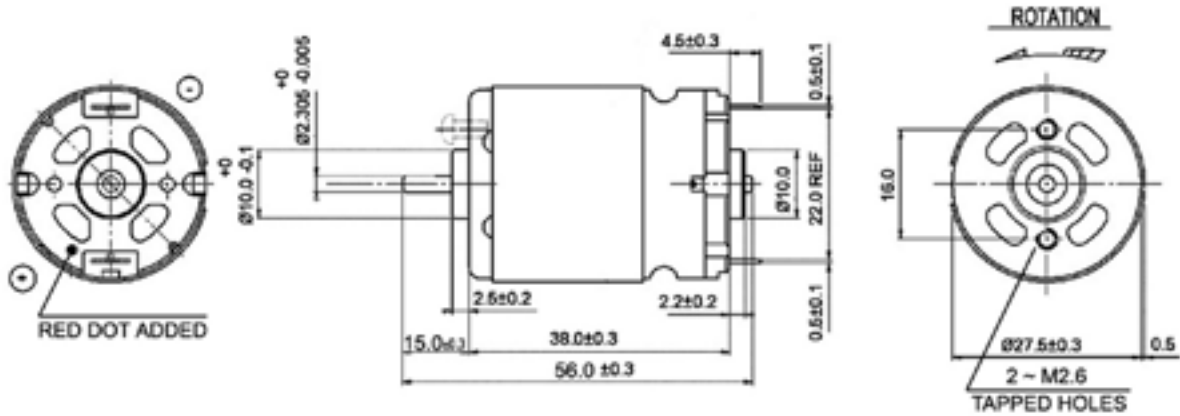

Unit in mm

## Performance Data:

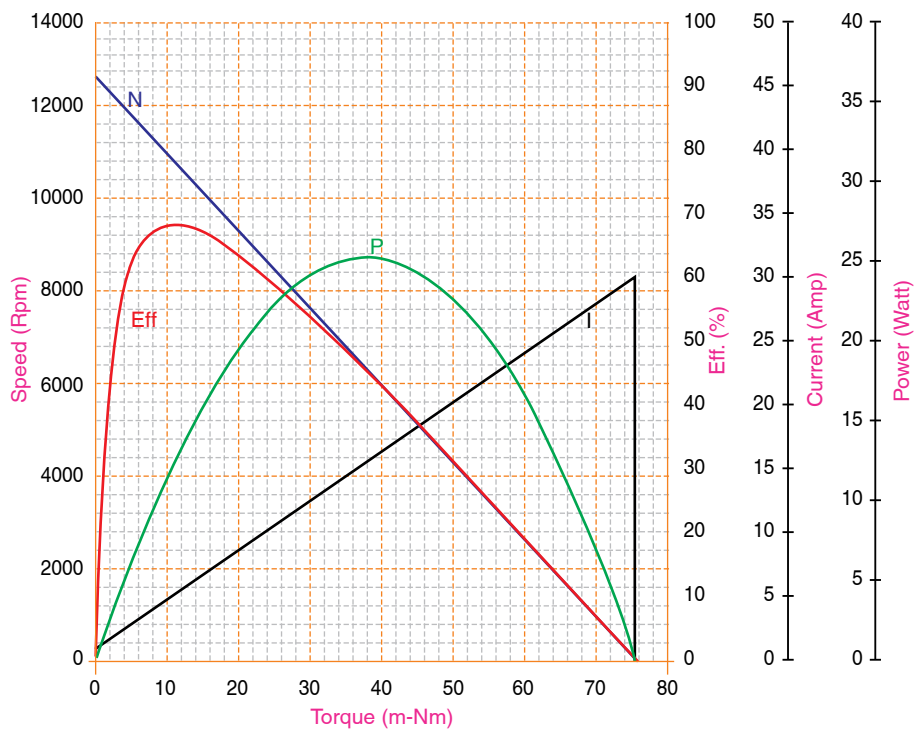

## Market

Personal Care

## Application:

Foot Bath (Bubble)



The most widely-used motor for foot bath bubble application

## Motor Characteristics:

Diameter	: 27.5 mm
Length	: 32.5 mm
Shaft Diameter	: 2.305 mm
Weight	: 50.2 g
Nominal Voltage	: 41 V
Torque Constant	: 20.506 m-Nm/A
Dynamic Resistance	: 21.399 Ohms
Motor Regulations	: 468.419 Rpm/m-Nm
Pole Number	: 5

## Standard Data:

Operation Temperature	: -10 — 50°C
Storage Temperature	: -20 — 100°C
Mounting	: Any position
Electrical Connection	: Terminal
Winding Temperature (Tmax)	: 180 °C
Direction of Rotation	: CCW
Standards	: RoHS

## Electrical Performance:

	No Load	Stall	Max Eff	Max Power
Speed (Rpm)	17799		15067	8900
Current (A)	0.06	1.92	0.35	0.99
Torque (mNm)		38.00	5.83	19.00
Efficiency (%)			64.60	
Power (W)			9.20	17.71

## Drawing:

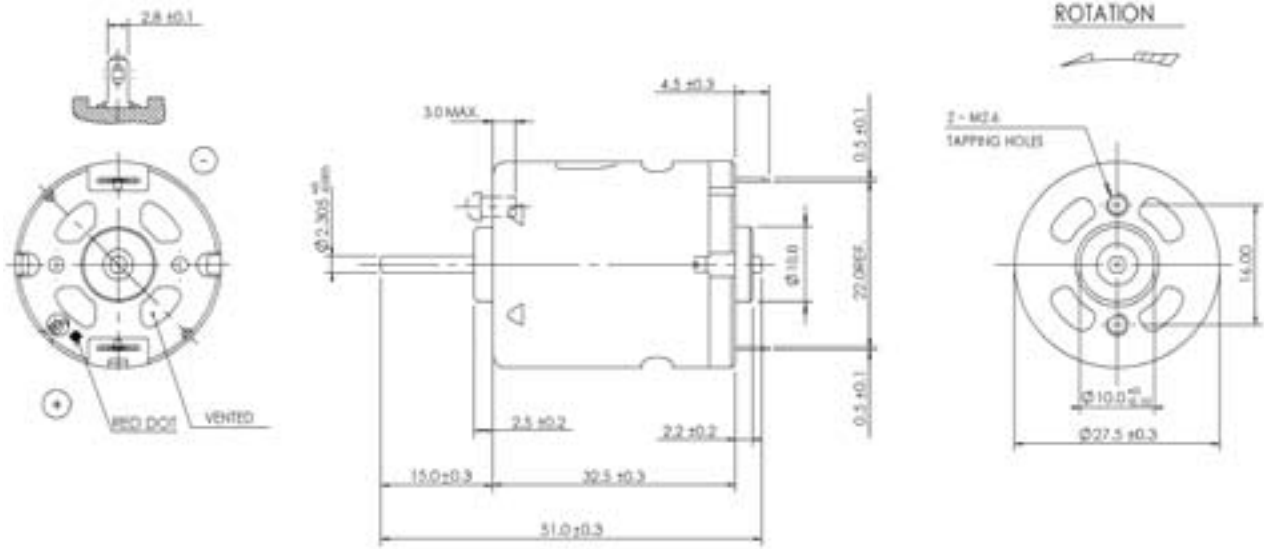

Unit in mm

## Performance Data:

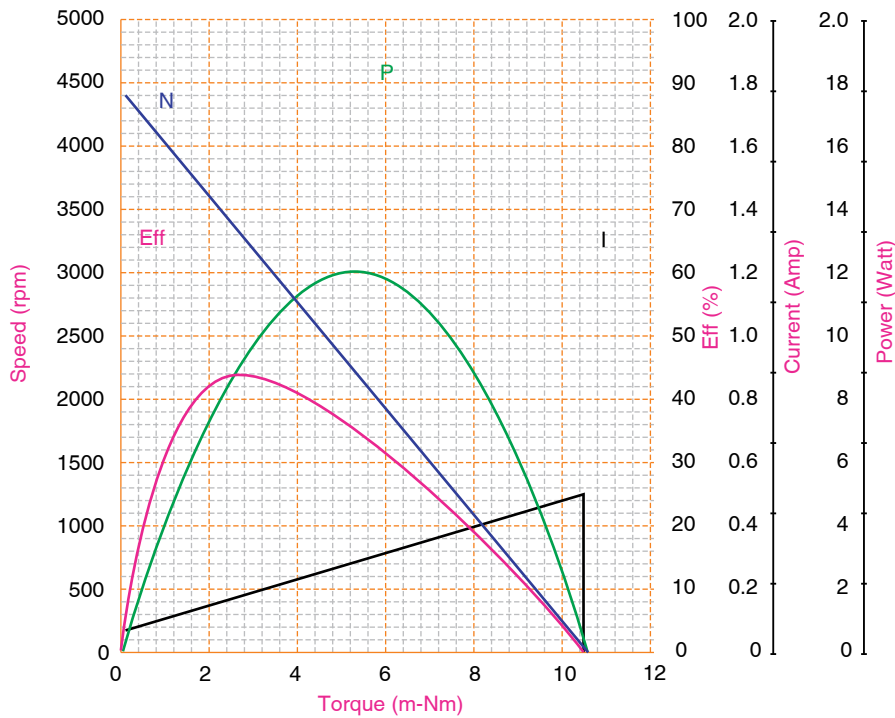

## Market

Personal Care

## Application:

Foot Bath



The most widely-used motor for foot bath bubble application

## Motor Characteristics:

Diameter	: 27.5 mm
Length	: 32.5 mm
Shaft Diameter	: 2.305 mm
Weight	: 48.5 g
Nominal Voltage	: 12 V
Torque Constant	: 23.81 m-Nm/A
Dynamic Resistance	: 23.952 Ohms
Motor Regulations	: 424.700 Rpm/m-Nm
Pole Number	: 5

## Standard Data:

Operation Temperature	: -10 — 50°C
Storage Temperature	: -20 — 100°C
Mounting	: Any position
Electrical Connection	: Terminal
Winding Temperature (Tmax)	: 180 °C
Direction of Rotation	: CCW
Standards	: RoHS

## Electrical Performance:

	No Load	Stall	Max Eff	Max Power
Speed (Rpm)	4419		3255	2210
Current (A)	0.06	0.50	0.18	0.28
Torque (mNm)		10.41	2.74	5.20
Efficiency (%)			43.47	
Power (W)			0.93	1.20

## Drawing:

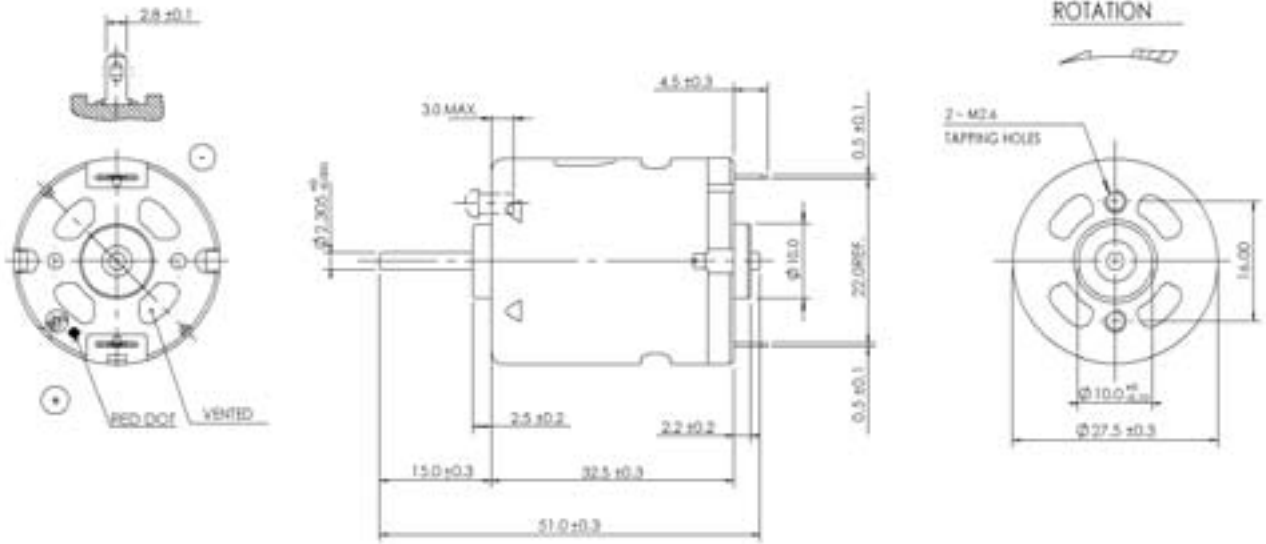

Unit in mm

## Performance Data:

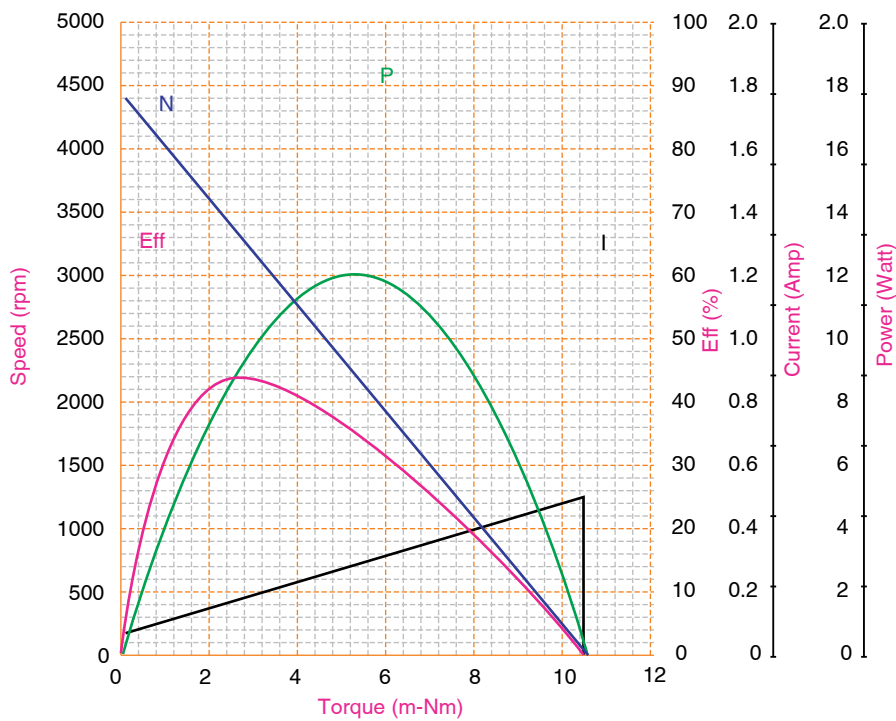

## Market

Personal Care

## Application:

Hair Dryer



Specially designed motor for low power hair dryer

## Motor Characteristics:

Diameter	: 27.5 mm
Length	: 32.5 mm
Shaft Diameter	: 2.305 mm
Weight	: 48.9 g
Nominal Voltage	: 17 V
Torque Constant	: 9.9095 m-Nm/A
Dynamic Resistance	: 3.989 Ohms
Motor Regulations	: 491.794 Rpm/n-Nm
Pole Number	: 5

## Standard Data:

Operation Temperature	: -10 — 50°C
Storage Temperature	: -20 — 100°C
Mounting	: Any position
Electrical Connection	: Terminal
Winding Temperature (Tmax)	: 180 °C
Direction of Rotation	: CCW
Standards	: RoHS

## Electrical Performance:

	No Load	Stall	Max Eff	Max Power
Speed (Rpm)	18070		14712	9035
Current (A)	0.22	4.26	0.97	2.24
Torque (mNm)		36.74	6.83	18.37
Efficiency (%)			63.61	
Power (W)			10.52	17.38

## Drawing:

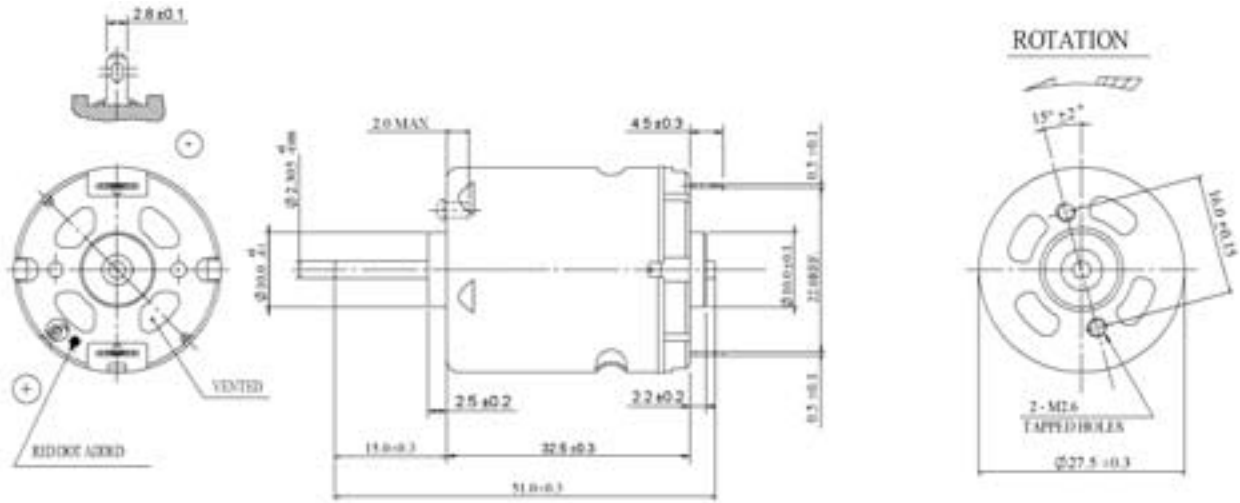

Unit in mm

## Performance Data:

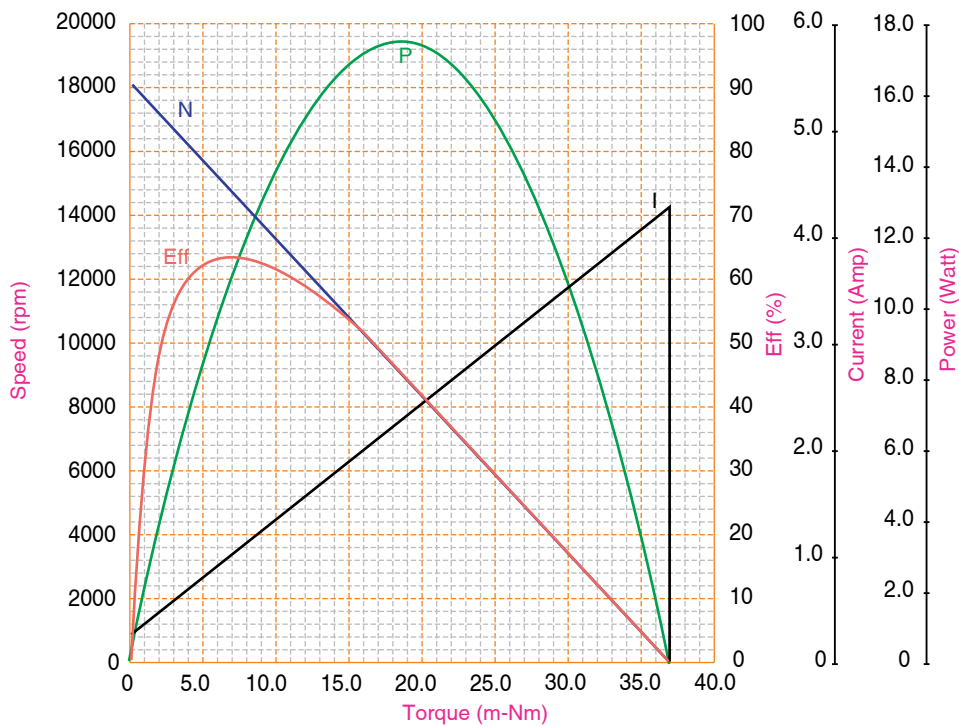

## Market

Personal Care

## Application:

Hair Dryer



Specially designed motor for hair dryer with cool shot feature

## Motor Characteristics:

Diameter	: 27.5 mm
Length	: 38 mm
Shaft Diameter	: 2.305 mm
Weight	: 65.6 g
Nominal Voltage	: 39 V
Torque Constant	: 18.613 m-Nm/A
Dynamic Resistance	: 10.114 Ohms
Motor Regulations	: 296.421 Rpm/m-Nm
Pole Number	: 5

## Standard Data:

Operation Temperature	: -10 — 50°C
Storage Temperature	: -20 — 100°C
Mounting	: Any position
Electrical Connection	: Terminal
Winding Temperature (Tmax)	: 180 °C
Direction of Rotation	: CCW
Standards	: RoHS

## Electrical Performance:

	No Load	Stall	Max Eff	Max Power
Speed (Rpm)	20316		17247	10256
Current (A)	0.13	3.86	0.73	2.00
Torque (mNm)		69.20	11.02	34.60
Efficiency (%)			69.88	
Power (W)			19.89	37.16



## Drawing:

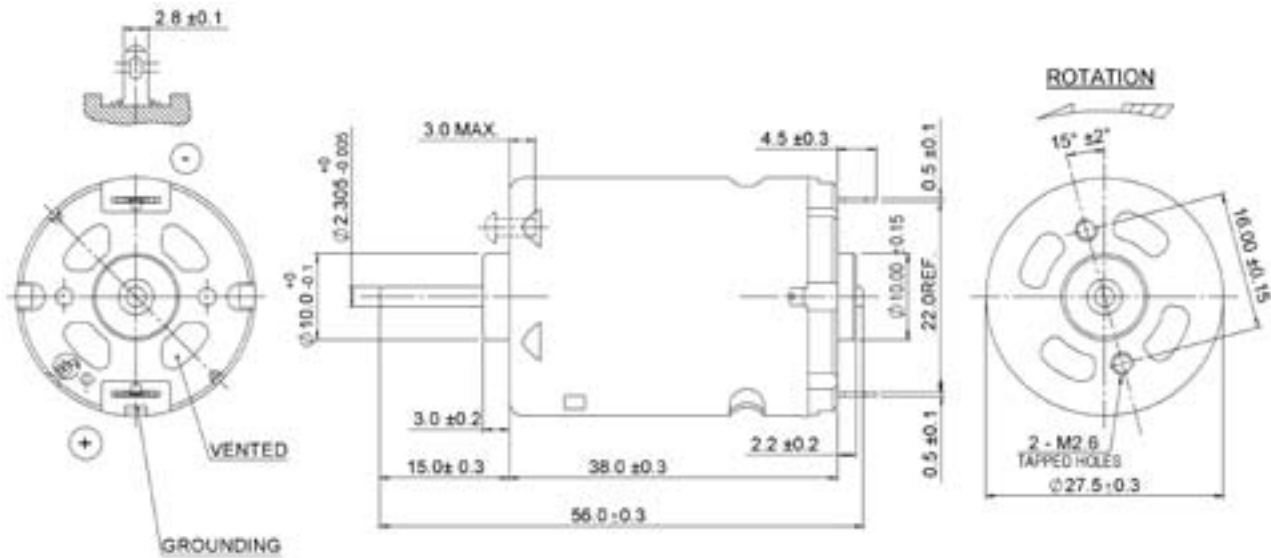

Unit in mm

## Performance Data:

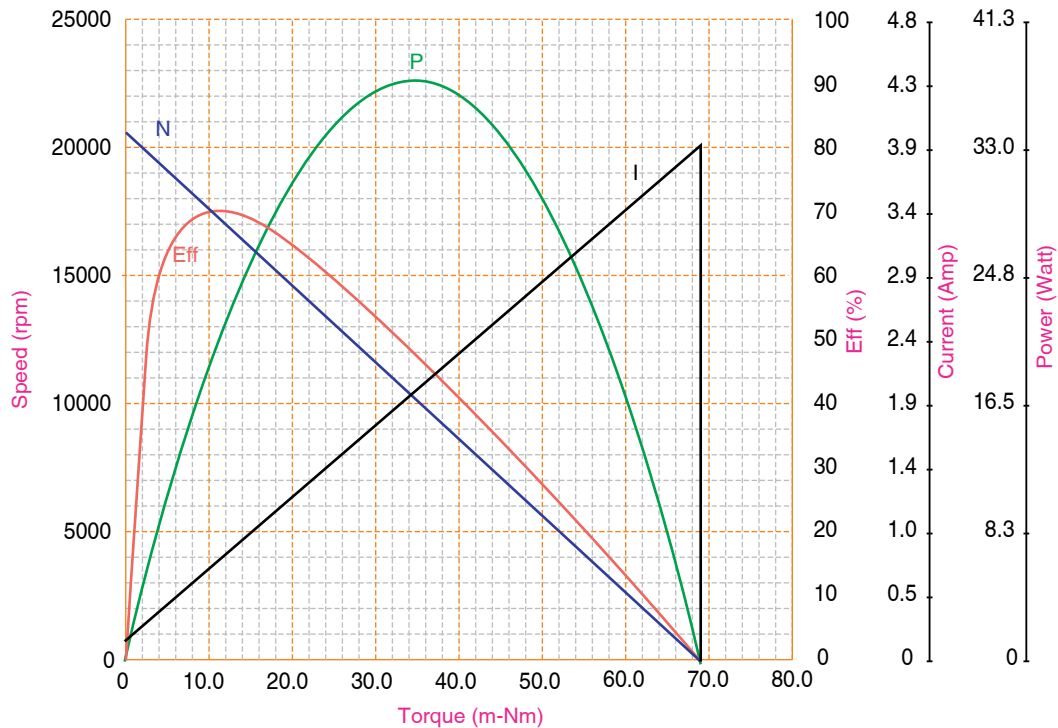

## Market

Personal Care

## Application:

Hair Dryer



Specially designed motor for mid-power hair dryer

## Motor Characteristics:

Diameter	: 27.5 mm
Length	: 38 mm
Shaft Diameter	: 2.305 mm
Weight	: 64.1 g
Nominal Voltage	: 24 V
Torque Constant	: 10.789 m-Nm/A
Dynamic Resistance	: 3.991 Ohms
Motor Regulations	: 353.71 Rpm/m-Nm
Pole Number	: 5

## Standard Data:

Operation Temperature	: -10 — 50°C
Storage Temperature	: -20 — 100°C
Mounting	: Any position
Electrical Connection	: Terminal
Winding Temperature (Tmax)	: 180 °C
Direction of Rotation	: CCW
Standards	: RoHS

## Electrical Performance:

	No Load	Stall	Max Eff	Max Power
Speed (Rpm)	22103		18547	11052
Current (A)	0.22	6.01	1.15	3.12
Torque (mNm)		62.49	10.05	31.25
Efficiency (%)			70.57	
Power (W)			19.53	36.16



## Market

Personal Care

## Application:

Hair Dryer

## Motor Characteristics:

Diameter	: 27.5 mm
Length	: 38 mm
Shaft Diameter	: 2.305 mm
Weight	: 65.5 g
Nominal Voltage	: 30 V
Torque Constant	: 15.402 m-Nm/A
Dynamic Resistance	: 4.756 Ohms
Motor Regulations	: 202.454 Rpm/m-Nm
Pole Number	: 5



Specially designed motor for high power hair dryer requiring high torque

## Standard Data:

Operation Temperature	: -10 — 50°C
Storage Temperature	: -20 — 100°C
Mounting	: Any position
Electrical Connection	: Terminal
Winding Temperature (Tmax)	: 180 °C
Direction of Rotation	: CCW
Standards	: RoHS

## Electrical Performance:

	No Load	Stall	Max Eff	Max Power
Speed (Rpm)	19055		16193	9528
Current (A)	0.20	6.31	1.12	3.25
Torque (mNm)		94.12	14.14	47.06
Efficiency (%)			71.67	
Power (W)			23.97	46.95

## Drawing:

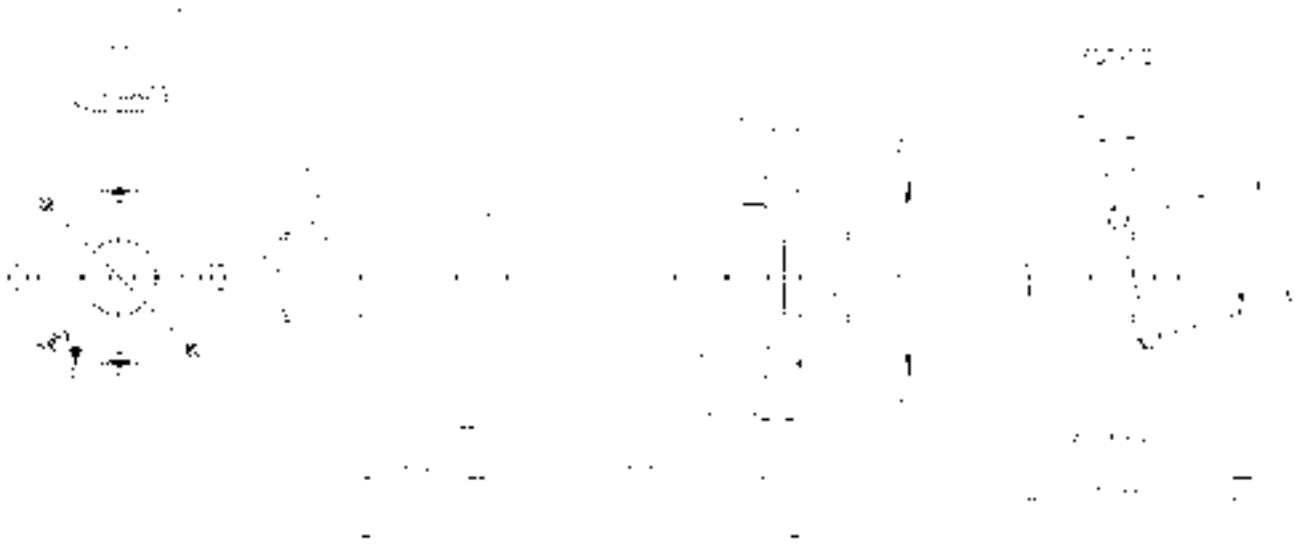

Unit in mm

PMDC

## Performance Data:

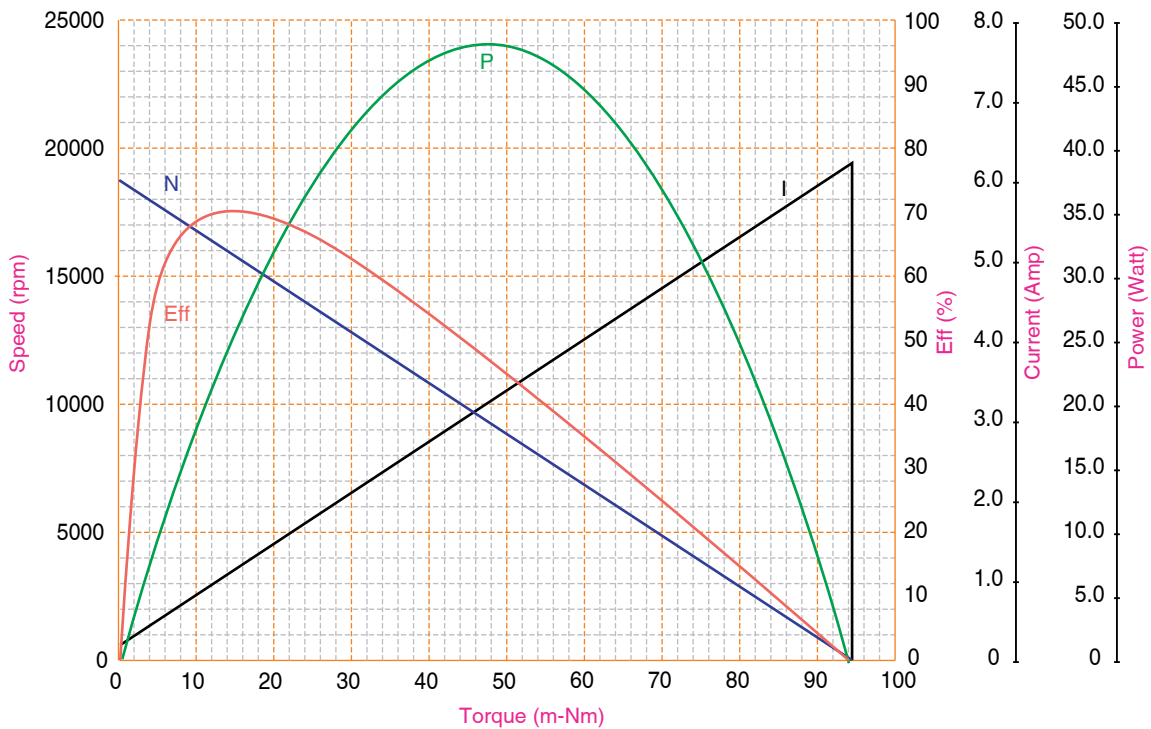

## Market

Personal Care

## Application:

Hair Dryer



Specially designed motor for high power hair dryer requiring high torque

## Motor Characteristics:

Diameter	: 27.5 mm
Length	: 38 mm
Shaft Diameter	: 2.305 mm
Weight	: 72.2 g
Nominal Voltage	: 24 V
Torque Constant	: 13.723 m-Nm/A
Dynamic Resistance	: 3.324 Ohms
Motor Regulations	: 172.007 Rpm/m-Nm
Pole Number	: 5

## Standard Data:

Operation Temperature	: -10 — 50°C
Storage Temperature	: -20 — 100°C
Mounting	: Any position
Electrical Connection	: Terminal
Winding Temperature (Tmax)	: 180 °C
Direction of Rotation	: CCW
Standards	: RoHS

## Electrical Performance:

	No Load	Stall	Max Eff	Max Power
Speed (Rpm)	16533		14090	8267
Current (A)	0.22	7.22	1.25	3.72
Torque (mNm)		96.12	14.20	48.06
Efficiency (%)			69.75	
Power (W)			20.95	41.60

## Drawing:

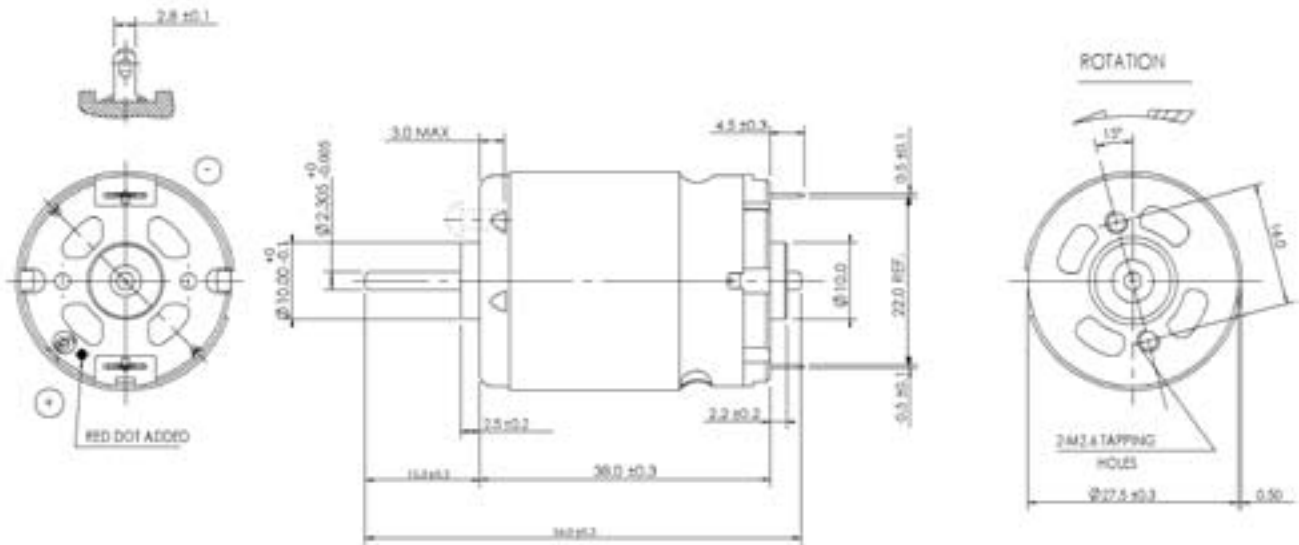

Unit in mm

## Performance Data:

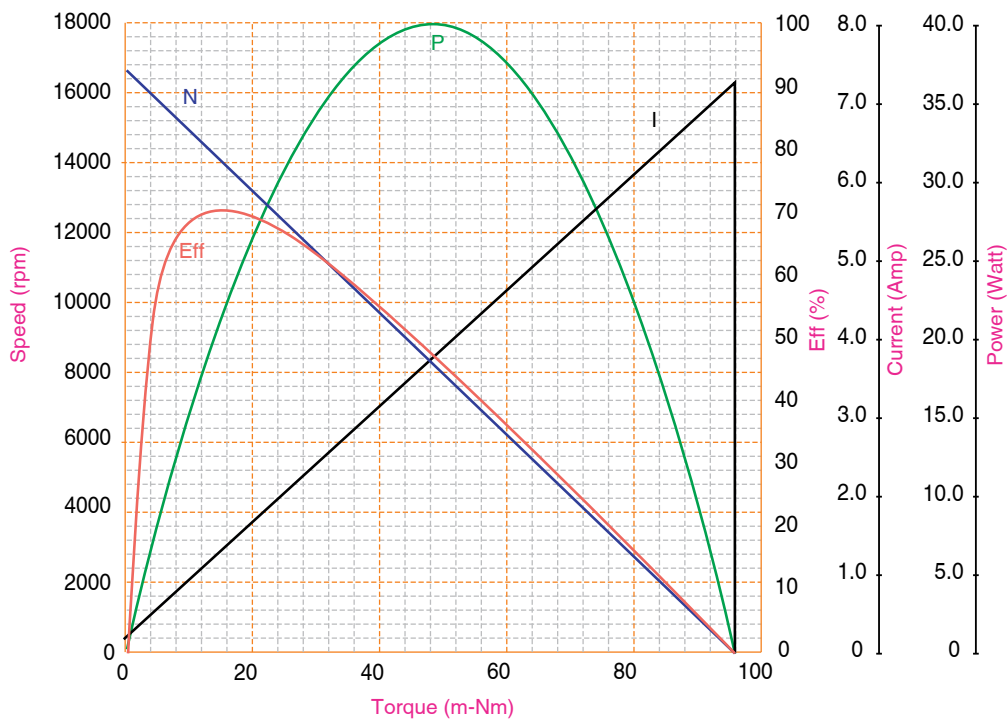

## Market

Personal Care

## Application:

Hair Dryer



Specially designed motor for high power yet quiet hair dryer.

## Motor Characteristics:

Diameter	: 27.5 mm
Length	: 38 mm
Shaft Diameter	: 2.305 mm
Weight	: 55 g
Nominal Voltage	: 18 V
Torgue Constant	: 11.332 m-Nm/Amp
Dynamic Resistance	: 3.402 Ohms
Motor Regulations	: 258.085 Rpm/m-Nm
Pole Number	: 5

## Standard Data:

Operation Temperature	: -10 — 55°C
Storage Temperature	: -20 — 100°C
Mounting	: Any position
Electrical Connection	: Terminal
Winding Temperature (Tmax)	: 180 °C
Direction of Rotation	: CCW
Standards	: RoHS

## Electrical Performance:

	No Load	Stall	Max Eff	Max Power (W)
Speed (Rpm)	14538		11849	7312
Current (A)	0.29	5.29	1.24	2.79
Torque (mNm)		56.67	10.76	28.33
Efficiency (%)			59.81	
Power (W)			13.34	21.70



## Drawing:

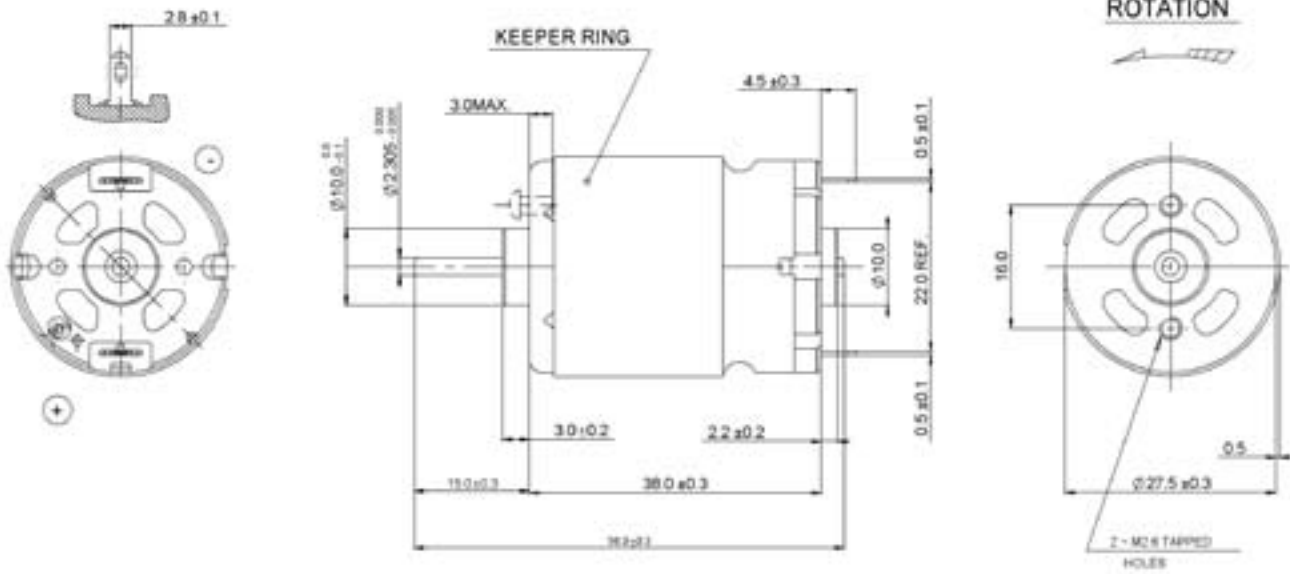

Unit in mm

## Performance Data:

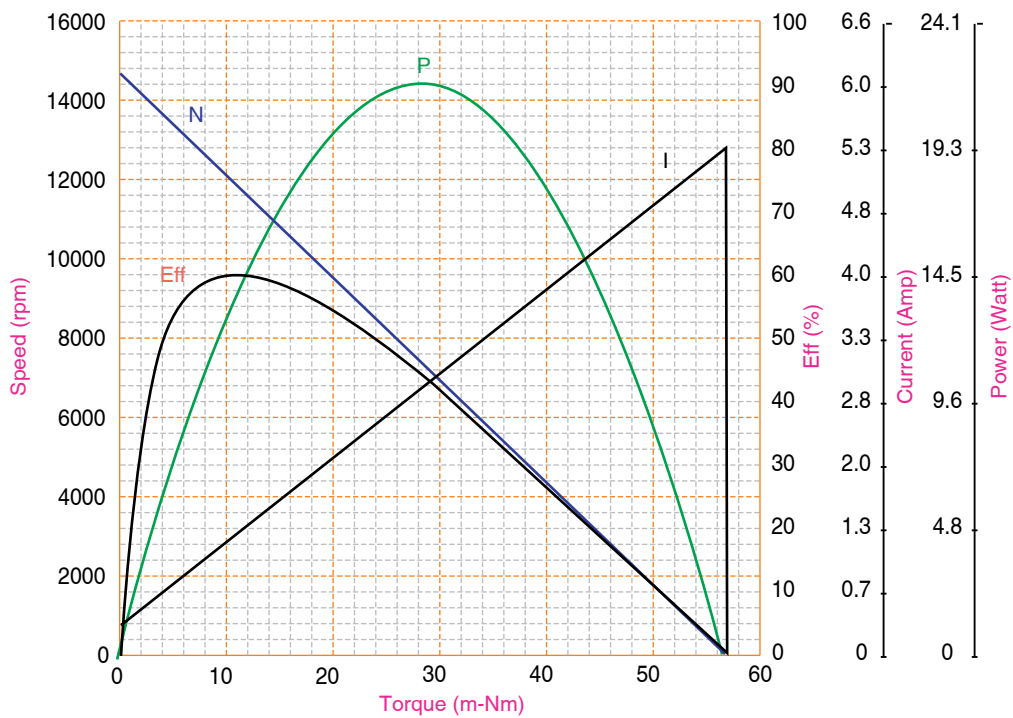

## Market

Business Machines

## Application:

Printer

## Motor Characteristics:

Diameter	: 27.5 mm
Length	: 32.5 mm
Shaft Diameter	: 2.305 mm
Weight	: 50 g
Nominal Voltage	: 18 V
Torque Constant	: 15.480 m-Nm/A
Dynamic Resistance	: 6.730 Ohms
Motor Regulations	: 248.816 Rpm/m-Nm
Pole Number	: 5



Motor for carriage and paper feeder applications in printer that has low peak-to-peak cogging, high performance, EMI suppression

## Standard Data:

Operation Temperature	: -10 — 55°C
Storage Temperature	: -20 — 100°C
Mounting	: Any position
Electrical Connection	: Terminal
Winding Temperature (Tmax)	: 130 °C
Direction of Rotation	: CW & CCW
Standards	: RoHS
Remarks	: Varistor

## Electrical Performance:

	No Load	Stall	Max Eff	Max Power (W)
Speed (Rpm)	9862		8175	4931
Current (A)	0.11	2.674	0.55	1.39
Torque (mNm)		39.64	6.78	19.82
Efficiency (%)			58.44	
Power (W)			5.81	10.24

## Drawing:

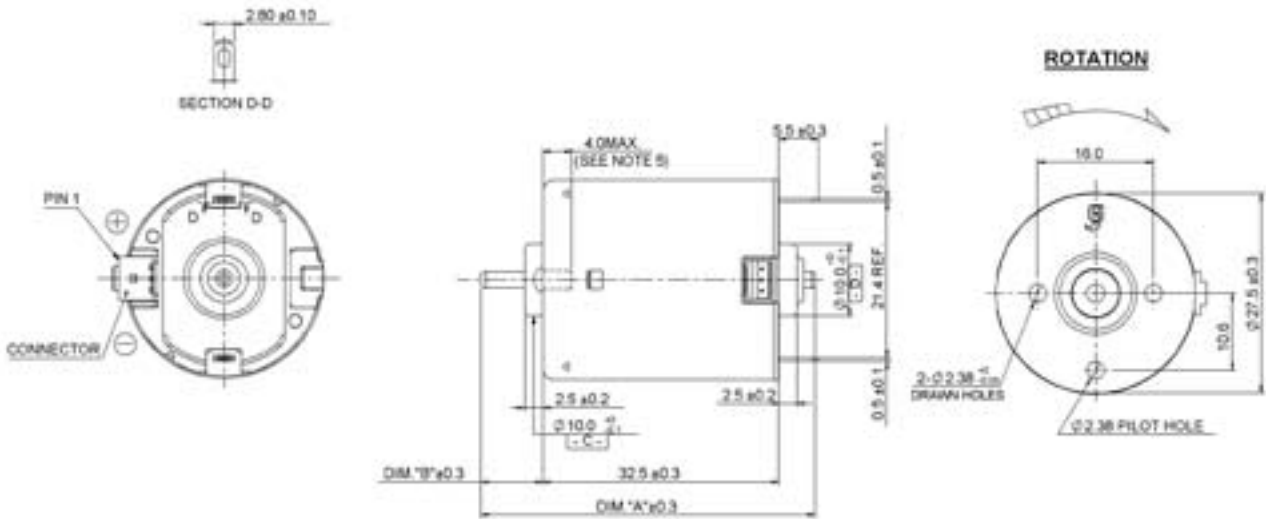

Unit in mm

## Performance Data:

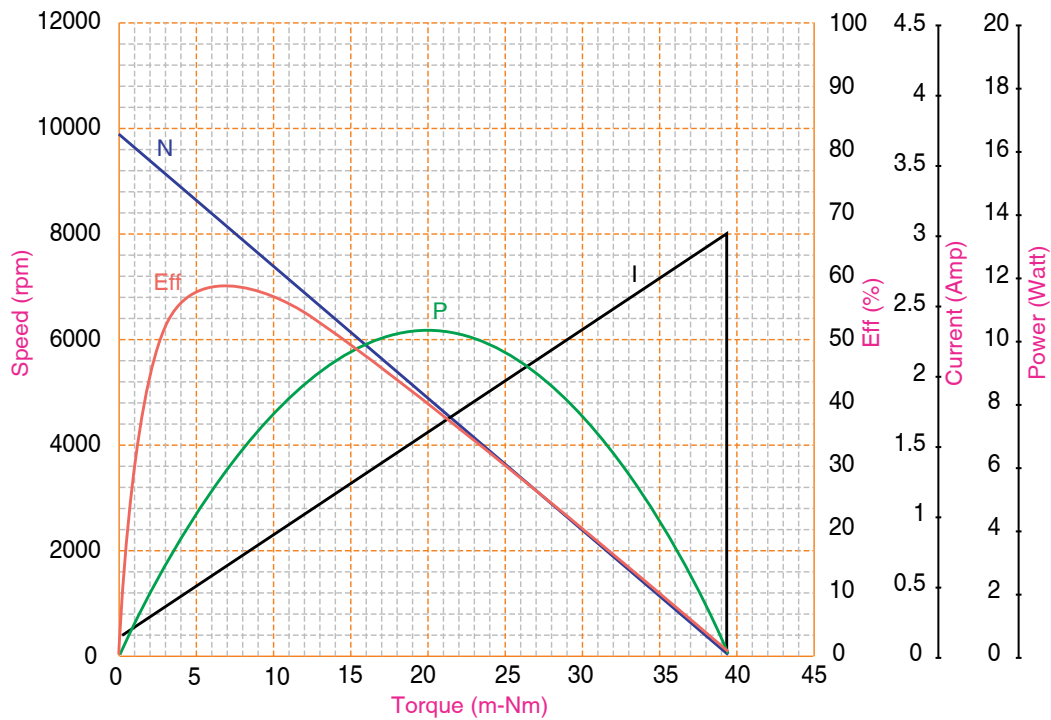

## Market

Business Machines

## Application:

Printer



High performance encoder system integrated with motor used for service station, scanner, automatic document feeder and speed control applications in printer. Encoder systems can be designed according to customer's requirement.

## Motor Characteristics:

Diameter	: 27.5 mm
Length	: 32.5 mm
Shaft Diameter	: 2.305 mm
Weight	: 69 g
Nominal Voltage	: 18 V
Torque Constant	: 27.464 m-Nm/A
Dynamic Resistance	: 25.675 Ohms
Motor Regulations	: 333.69 Rpm/m-Nm
Pole Number	: 5
Output Singal	: Digital, Analog

## Standard Data:

Operation Temperature	: -10 — 55°C
Storage Temperature	: -20 — 100°C
Mounting	: Any position
Electrical Connection	: Connector
Direction of Rotation	: CW

## Electrical Performance:

	No Load	Stall	Max Eff	Max Power (W)
Speed (Rpm)	5800		4470	2900
Current (A)	0.060	0.70	0.21	0.38
Torque (mNm)		17.80	4.08	8.87
Efficiency (%)			51.77	
Power (W)			1.91	2.69

## Drawing:

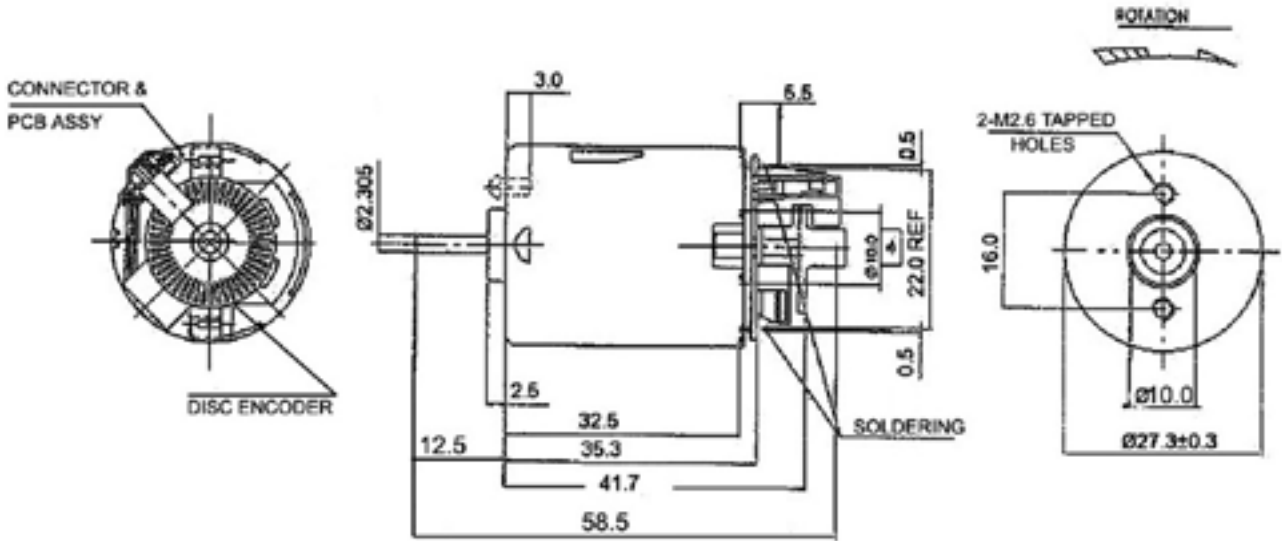

Unit in mm

## Performance Data:

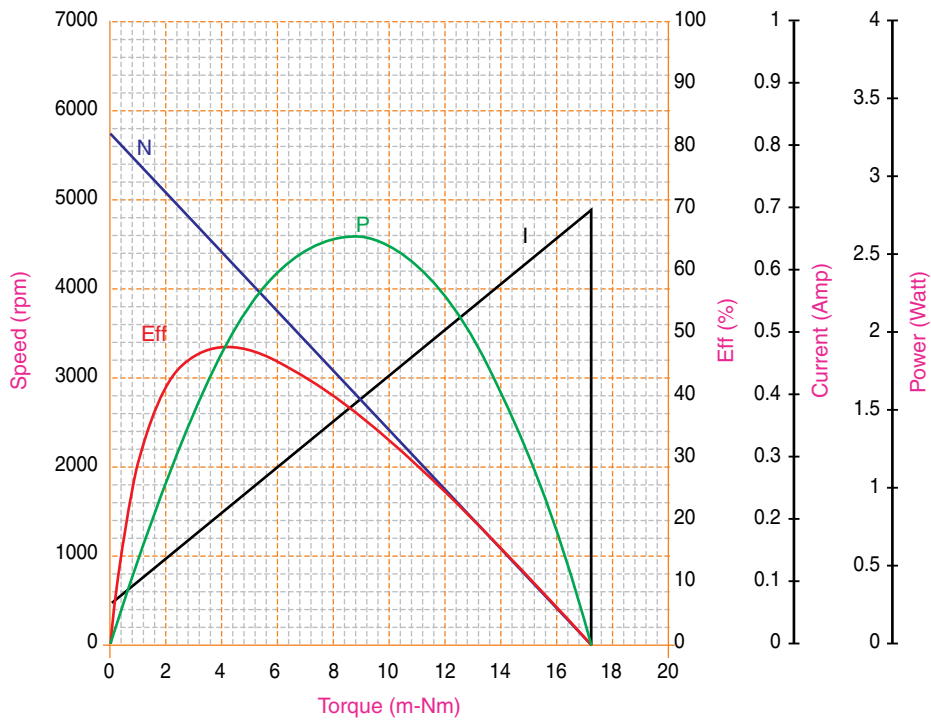

## Market

Business Machines

## Application:

Printer

## Motor Characteristics:

Diameter	: 27.5 mm
Length	: 32.5 mm
Shaft Diameter	: 3.175 mm
Weight	: 55 g
Nominal Voltage	: 42 V
Torque Constant	: 39.704 m-Nm/A
Dynamic Resistance	: 48.603 Ohms
Motor Regulations	: 286.541 Rpm/m-Nm
Pole Number	: 5



Specially designed for high torque applications

## Standard Data:

Operation Temperature	: -10 — 50°C
Storage Temperature	: -20 — 100°C
Mounting	: Any position
Electrical Connection	: Terminal
Winding Temperature (Tmax)	: 180 °C
Direction of Rotation	: CCW

## Electrical Performance:

	No Load	Stall	Max Eff	Max Power
Speed (Rpm)	8986		6951	4491
Current (A)	0.07	0.86	0.25	0.47
Torque (mNm)		31.37	7.10	15.69
Efficiency (%)			48.70	
Power (W)			5.17	7.38



## Market

Business Machines

## Application:

Printer



Motor designed for printer carriage application, with low peak-to-peak cogging for a smoother printing operation

## Motor Characteristics:

Diameter	: 27.5 mm
Length	: 38 mm
Shaft Diameter	: 2.305 mm
Weight	: 77 g
Nominal Voltage	: 24 V
Torque Constant	: 39.934 m-Nm/A
Dynamic Resistance	: 20.507 Ohms
Motor Regulations	: 123.118 Rpm/m-Nm
Pole Number	: 5

## Standard Data:

Operation Temperature	: -10 — 55°C
Storage Temperature	: -20 — 100°C
Mounting	: Any position
Electrical Connection	: Terminal
Winding Temperature (Tmax)	: 155 °C
Direction of Rotation	: CCW
Standards	: RoHS

## Electrical Performance:

	No Load	Stall	Max Eff	Max Power (W)
Speed (Rpm)	5500		4500	2700
Current (A)	0.058	1.17	0.261	0.614
Torque (mNm)		44.42	8.09	22.210
Efficiency (%)			60.59	
Power (W)			3.788	6.357



## Drawing:

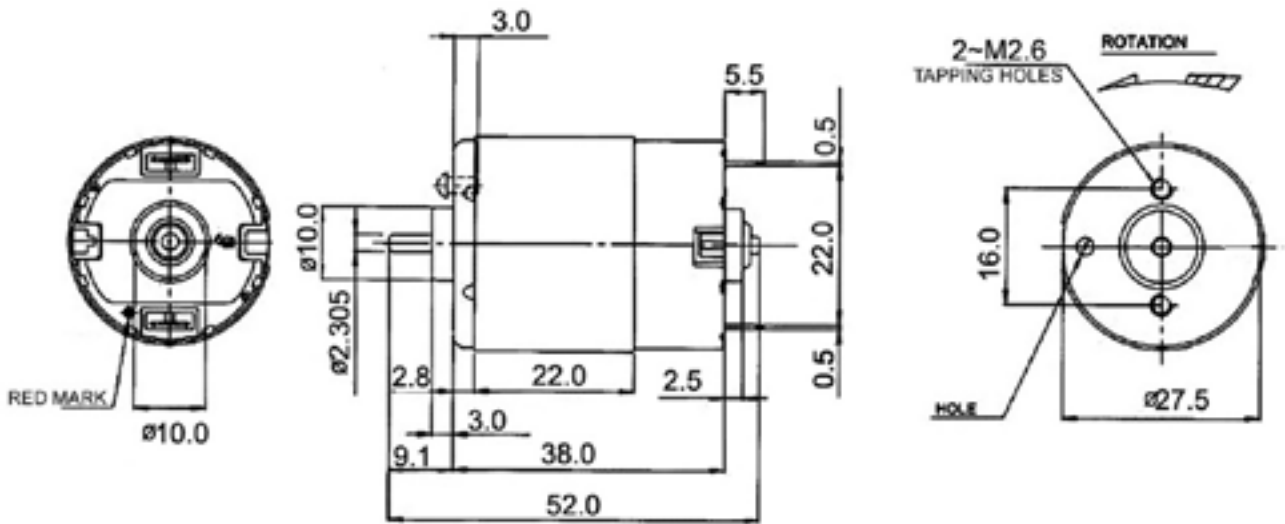

Unit in mm

## Performance Data:

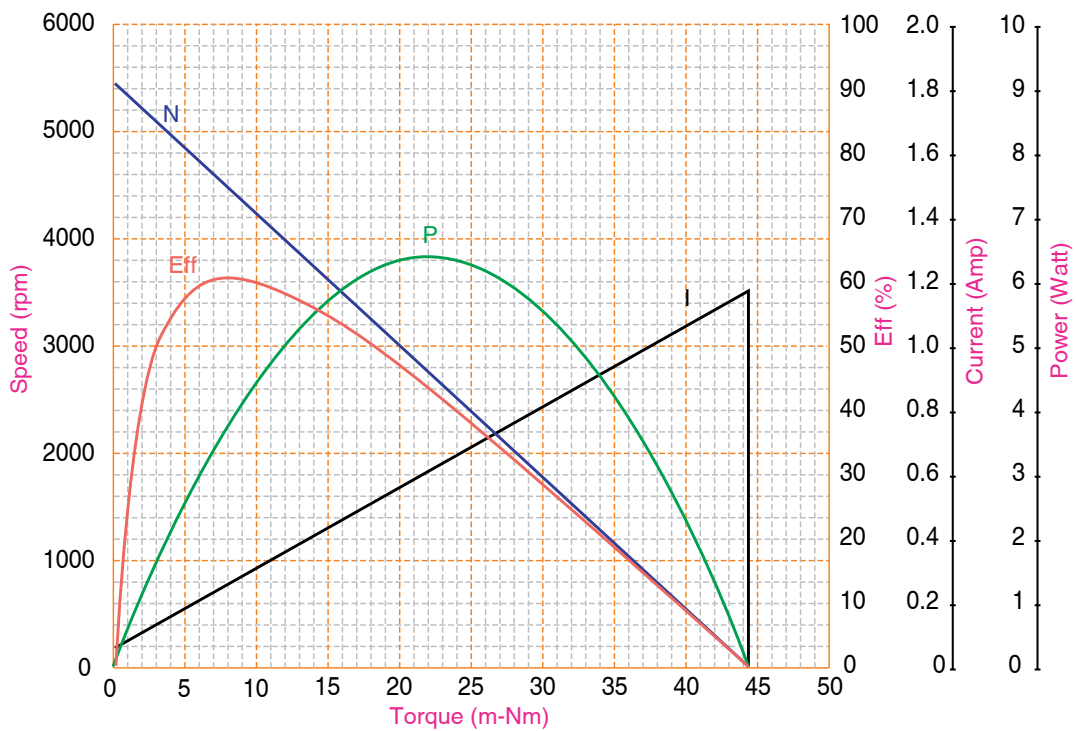

## Market

Business Machines

## Application:

Printer

## Motor Characteristics:

Diameter	: 27.5 mm
Length	: 38 mm
Shaft Diameter	: 2.305 mm
Weight	: 76 g
Nominal Voltage	: 23.5 V
Torque Constant	: 24.241 m-Nm/A
Dynamic Resistance	: 9.345 Ohms
Motor Regulations	: 152.667 Rpm/m-Nm
Pole Number	: 5



Low peak-to-peak cogging motor for paper feeder used on mid-range printers

## Standard Data:

Operation Temperature	: -10 — 55°C
Storage Temperature	: -20 — 100°C
Mounting	: Any position
Electrical Connection	: Terminal
Winding Temperature (Tmax)	: 130 °C
Direction of Rotation	: CW
Standards	: RoHS
Remarks	: Varistor

## Electrical Performance:

	No Load	Stall	Max Eff	Max Power (W)
Speed (Rpm)	8900		7500	4500
Current (A)	0.1	2.52	0.501	1.307
Torque (mNm)		58.539	9.732	29.269
Efficiency (%)			64.44	
Power (W)			7.593	13.691

## Drawing:

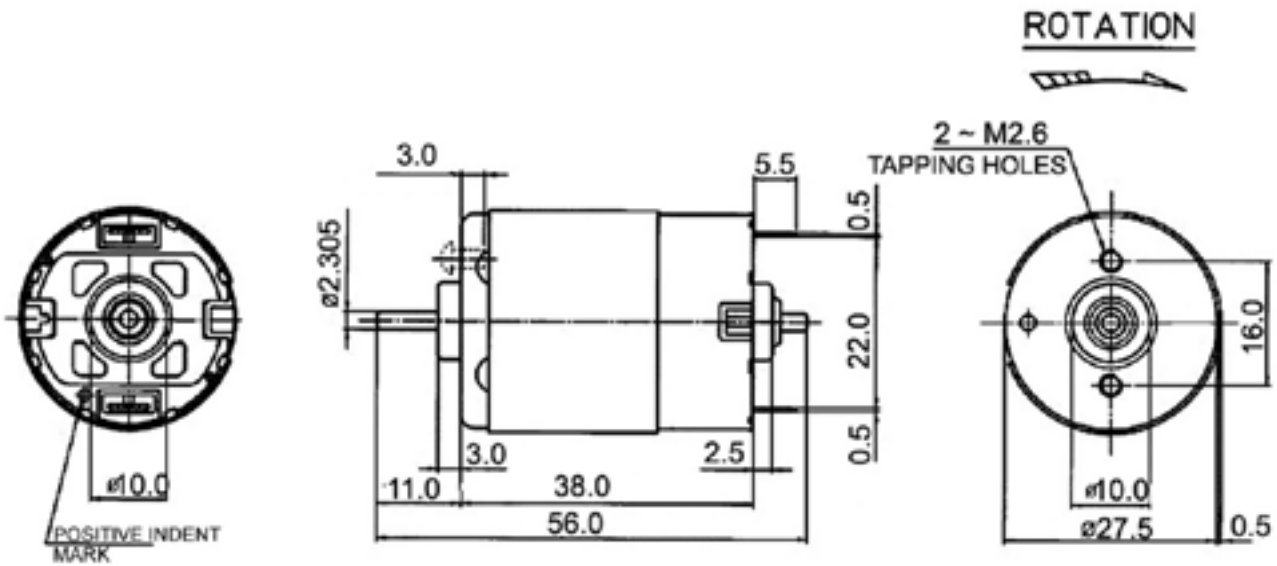

Unit in mm

## Performance Data:

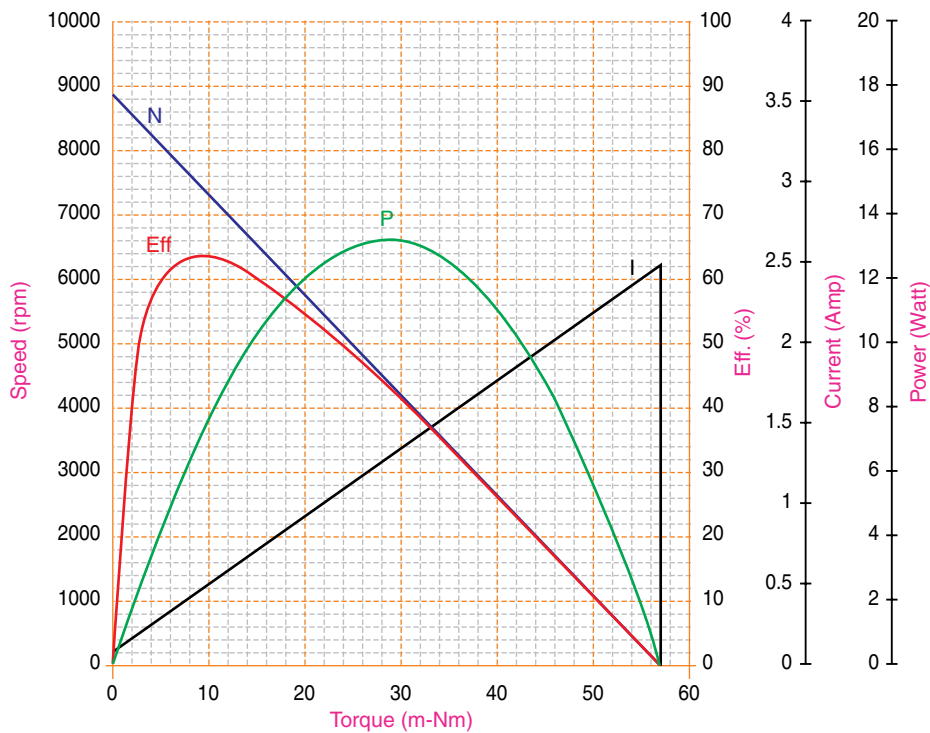

## Market

Business Machines

## Application:

Printer



High power and low peak-to-peak cogging paper feeder for high-end photo printers

## Motor Characteristics:

Diameter	: 27.5 mm
Length	: 38 mm
Shaft Diameter	: 2.305 mm
Weight	: 92.8 g
Nominal Voltage	: 23.5 V
Torque Constant	: 25.751 m-Nm/A
Dynamic Resistance	: 8.179 Ohms
Motor Regulations	: 119.577 Rpm/m-Nm
Pole Number	: 5

## Standard Data:

Operation Temperature	: -10 — 55°C
Storage Temperature	: -20 — 100°C
Mounting	: Any position
Electrical Connection	: Terminal
Winding Temperature (Tmax)	: 130 °C
Direction of Rotation	: CW
Standards	: RoHS

## Electrical Performance:

	No Load	Stall	Max Eff	Max Power (W)
Speed (Rpm)	8600		7300	4300
Current (A)	0.1	2.873	0.537	1.487
Torque (mNm)		71.411	11.228	35.706
Efficiency (%)			67.17	
Power (W)			8.461	15.958

## Drawing:

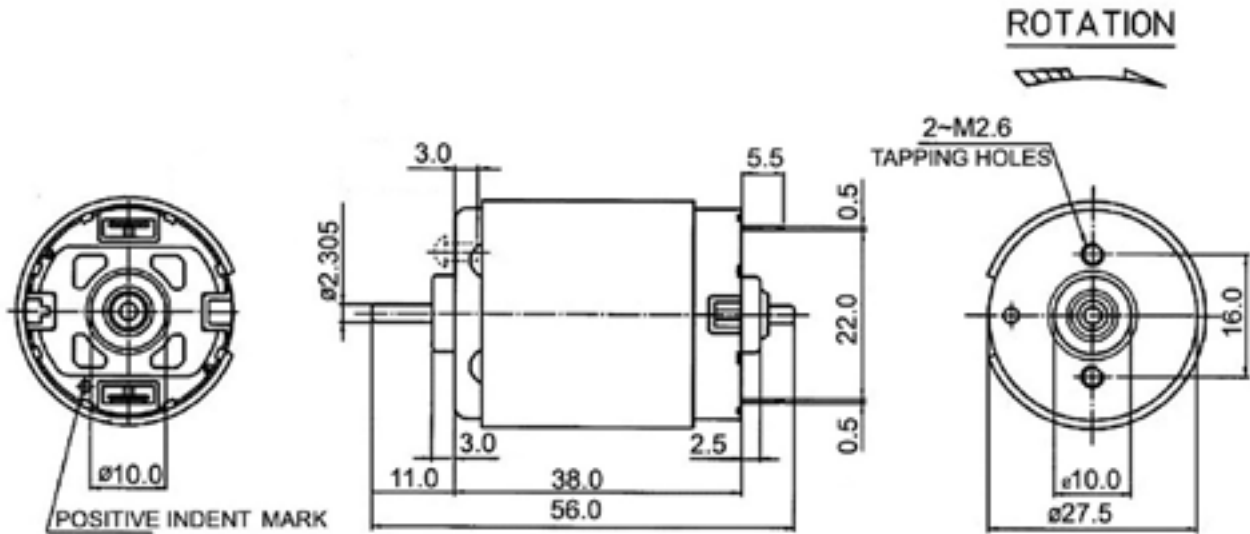

Unit in mm

## Performance Data:

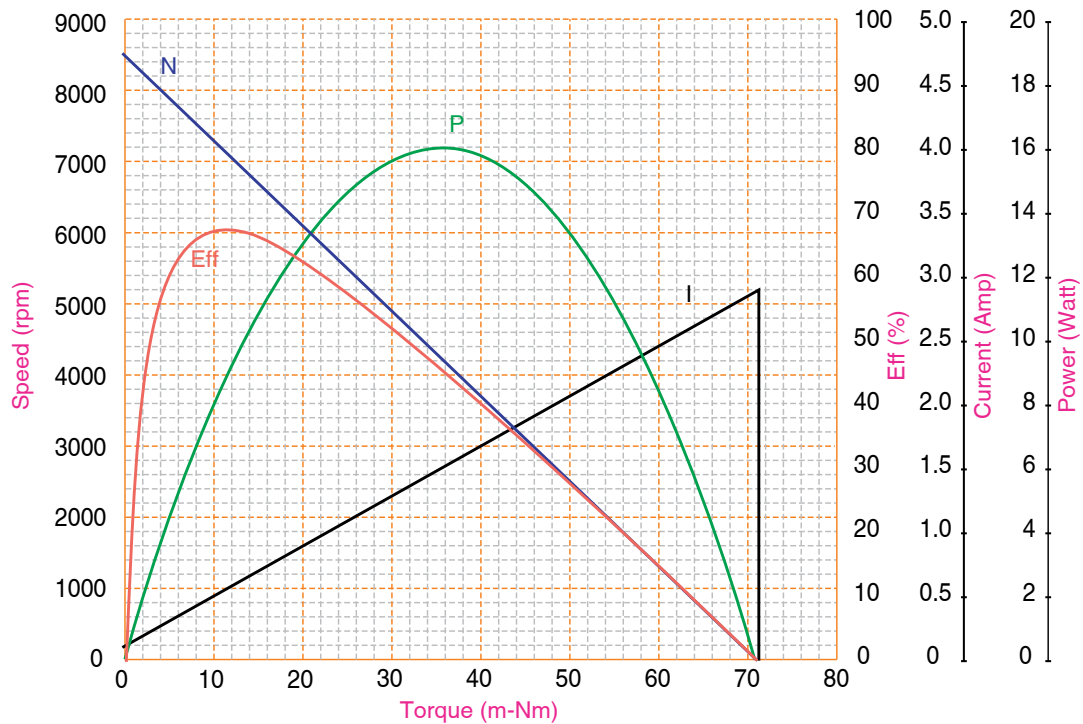

## Market

Business Machines

## Application:

Printer



Extra high power paper feeder motor for A3 size mid-range printers

## Motor Characteristics:

Diameter	: 27.5 mm
Length	: 46.5 mm
Shaft Diameter	: 2.305 mm
Weight	: 110 g
Nominal Voltage	: 23.5 V
Torque Constant	: 34.04 m-Nm/A
Dynamic Resistance	: 10.513 Ohms
Motor Regulations	: 85.668 Rpm/m-Nm
Pole Number	: 5

## Standard Data:

Operation Temperature	: -10 — 55°C
Storage Temperature	: -20 — 100°C
Mounting	: Any position
Electrical Connection	: Terminal
Winding Temperature (Tmax)	: 130 °C
Direction of Rotation	: CW
Standards	: RoHS
Remarks	: Varistor

## Electrical Performance:

	No Load	Stall	Max Eff	Max Power (W)
Speed (Rpm)	6300		5300	3100
Current (A)	0.071	2.235	0.399	1.153
Torque (mNm)		73.667	11.17	36.833
Efficiency (%)			66.71	
Power (W)			6.26	12.166

## Drawing:

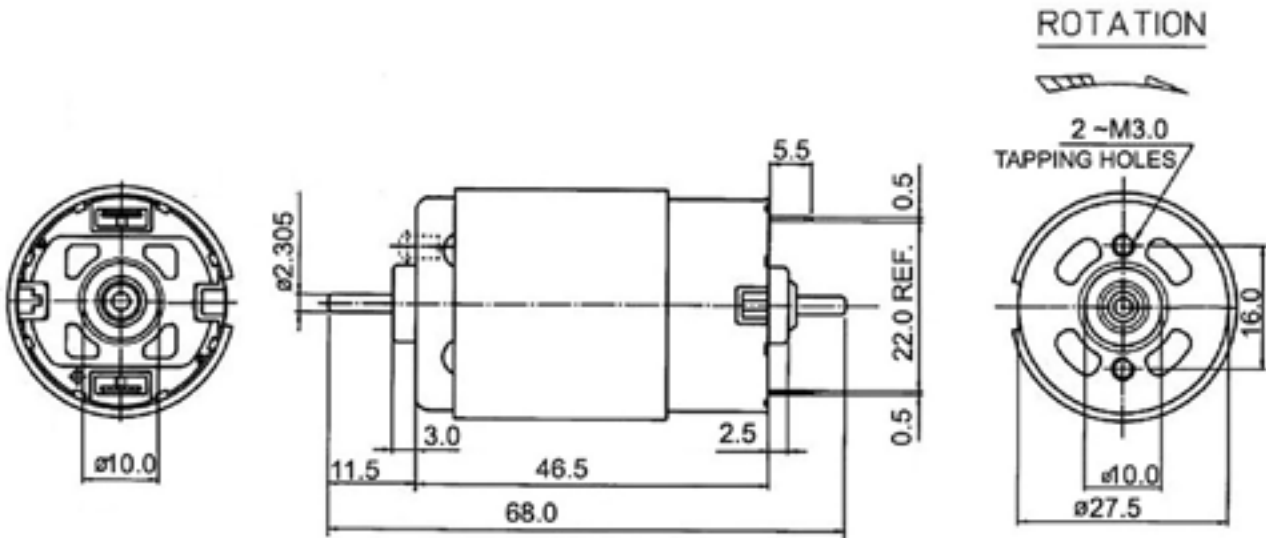

Unit in mm

## Performance Data:

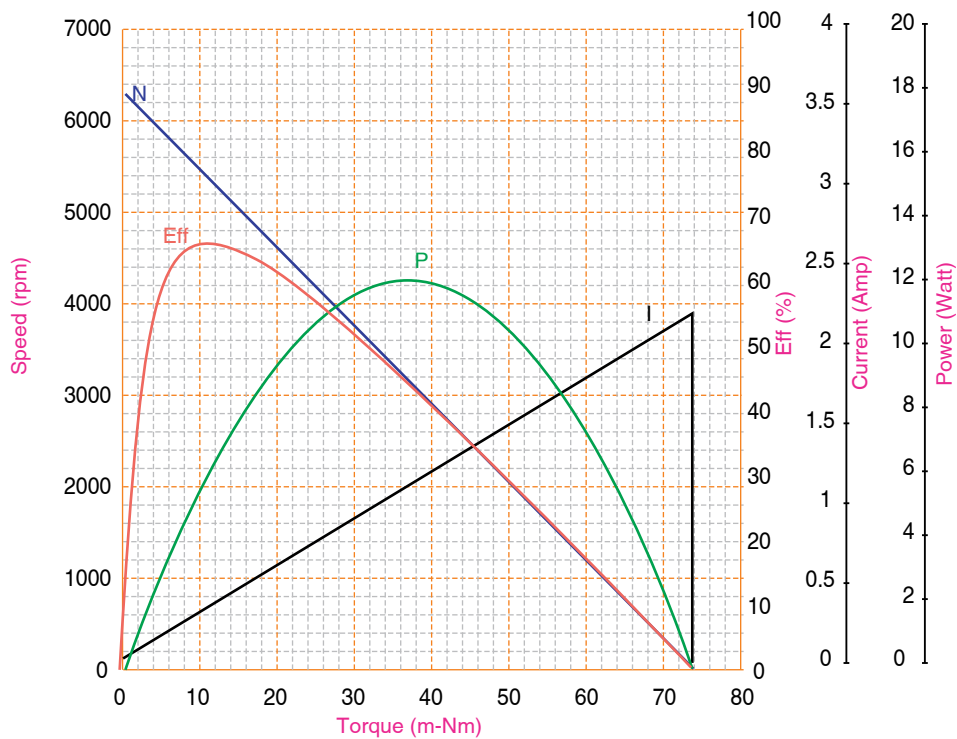

## Market

Personal Care, Business Machines

## Application:

Hair Dryer,



## Motor Characteristics:

Diameter	: 27.5 mm
Length	: 46.5 mm
Shaft Diameter	: 2.305 mm
Weight	: 88.6 g
Nominal Voltage	: 28 V
Torque Constant	: 13.627 m-Nm/A
Dynamic Resistance	: 2.644 Ohms
Motor Regulations	: 132.018 Rpm/m-Nm
Pole Number	: 5

## Standard Data:

Operation Temperature	: -10 — 50°C
Storage Temperature	: -20 — 100°C
Mounting	: Any position
Electrical Connection	: Terminal
Winding Temperature (Tmax)	: 180 °C
Direction of Rotation	: CCW
Standards	: RoHS

## Electrical Performance:

	No Load	Stall	Max Eff	Max Power (W)
Speed (Rpm)	18782		16773	9391
Current (A)	0.152	10.592	1.27	5.37
Torque (mNm)		142.27	15.22	71.14
Efficiency (%)			75.24	
Power (W)			26.73	69.96



## Drawing:

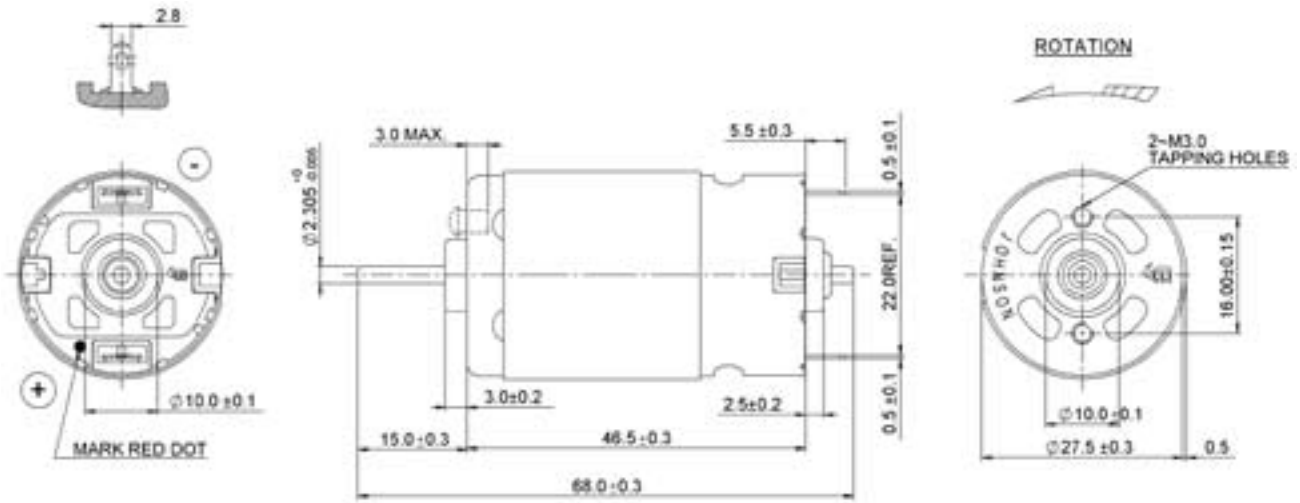

Unit in mm

## Performance Data:

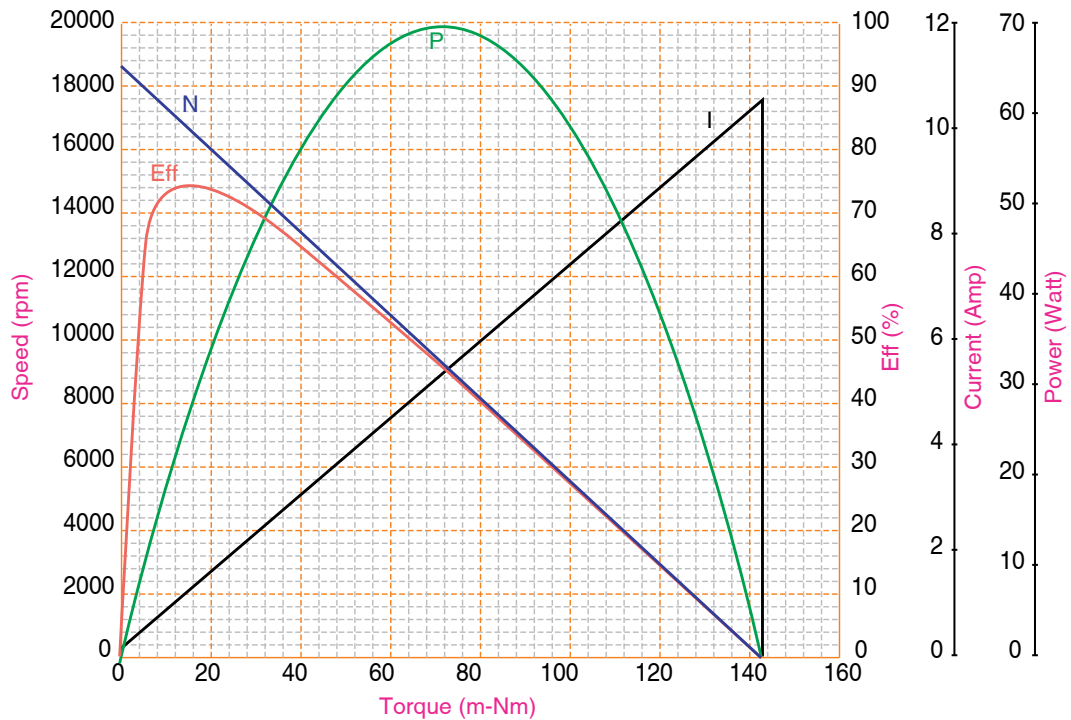

## Market

Personal Care

## Application:

Foot Bath



Compact high power motor used for foot bath waterjet application

## Motor Characteristics:

Diameter	: 27.5 mm
Length	: 46.5 mm
Shaft Diameter	: 2.305 mm
Weight	: 91 g
Nominal Voltage	: 36 V
Torque Constant	: 30.589 m-Nm/A
Dynamic Resistance	: 11.74 Ohms
Motor Regulations	: 119.422 Rpm/m-Nm
Pole Number	: 5

## Standard Data:

Operation Temperature	: -10 — 50°C
Storage Temperature	: -20 — 100°C
Mounting	: Any position
Electrical Connection	: Terminal
Winding Temperature (Tmax)	: 180 °C
Direction of Rotation	: CCW
Standards	: RoHS

## Electrical Performance:

	No Load	Stall	Max Eff	Max Power
Speed (Rpm)	10900		9500	5500
Current (A)	0.073	3.066	0.473	1.57
Torque (mNm)		91.56	12.24	45.78
Efficiency (%)			71.31	
Power (W)			12.146	26.221

## Drawing:

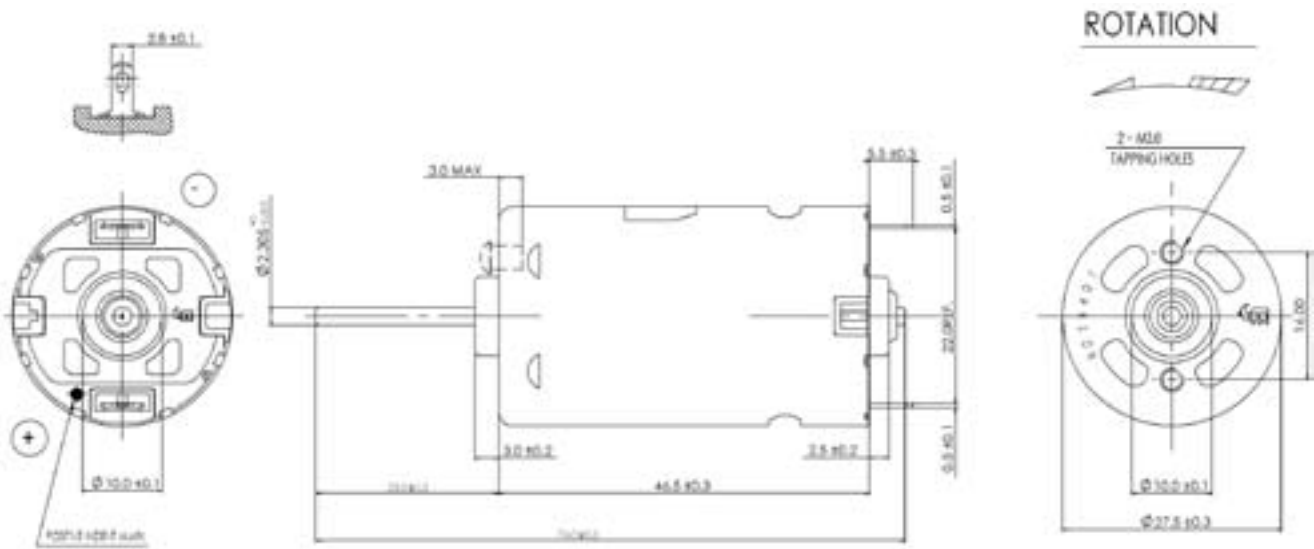

Unit in mm

## Performance Data:

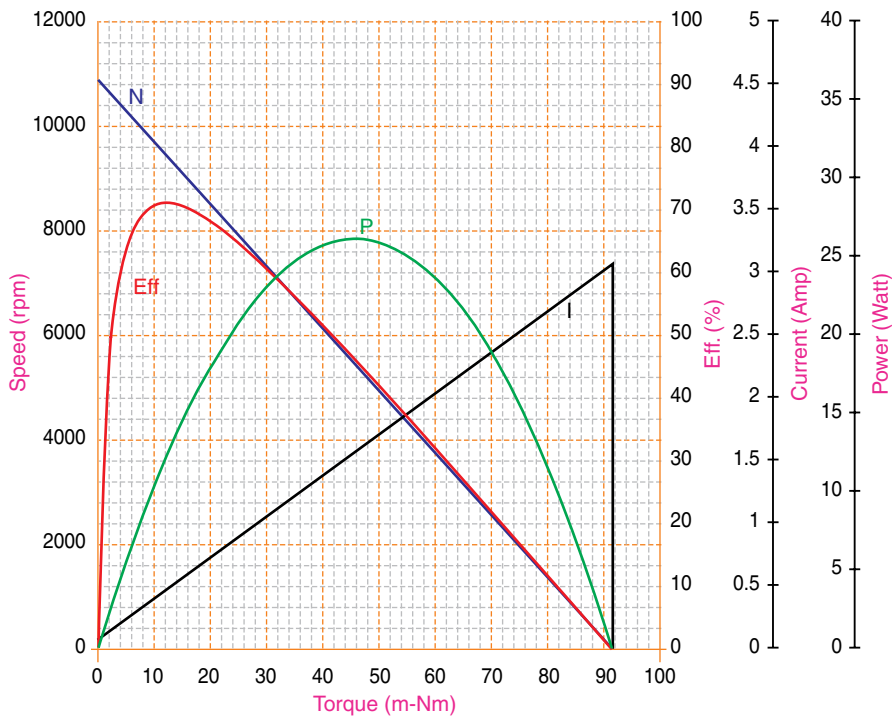

## Market

Business Machines

## Application:

Printer



Multifunctional low peak-to-peak cogging motor for mid-range printers designed for printer carriage and paper feeder applications.

## Motor Characteristics:

Diameter	: 29.0 mm
Length	: 47 mm
Shaft Diameter	: 3.175 mm
Weight	: 121.3 g
Nominal Voltage	: 42 V
Torque Constant	: 57.484 m-Nm/A
Dynamic Resistance	: 27.189 Ohms
Motor Regulations	: 77.181 Rpm/m-Nm
Pole Number	: 5

## Standard Data:

Operation Temperature	: -10 — 55°C
Storage Temperature	: -20 — 100°C
Mounting	: Any position
Electrical Connection	: Terminal
Winding Temperature (Tmax)	: 200 °C
Direction of Rotation	: CW
Standards	: RoHS
Remarks	: Varistor

## Electrical Performance:

	No Load	Stall	Max Eff	Max Power
Speed (Rpm)	6617		5600	3300
Current (A)	0.053	1.545	0.285	0.799
Torque (mNm)		85.77	13.37	42.886
Efficiency (%)			65.30	
Power (W)			7.823	14.859

## Drawing:

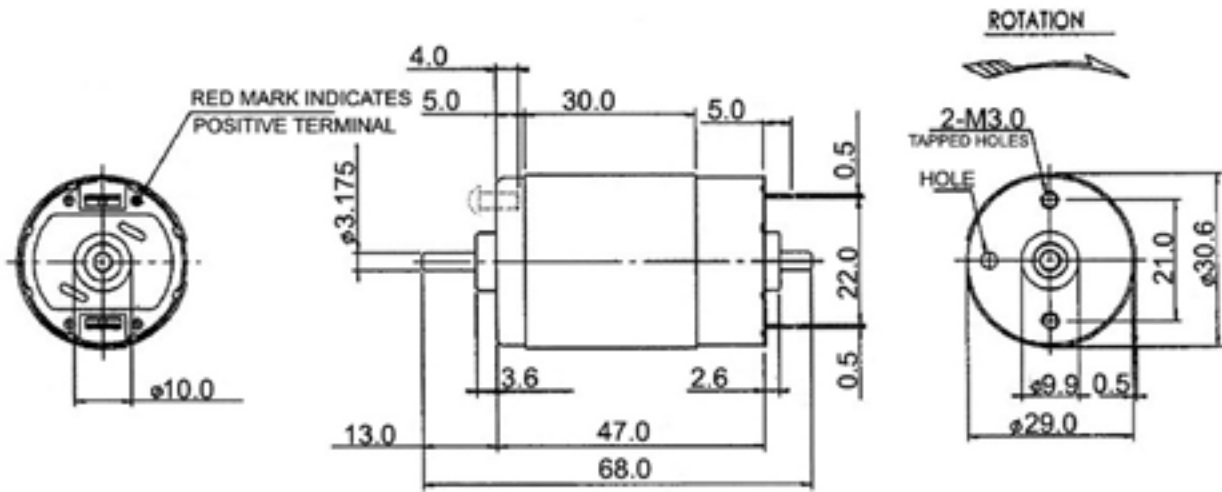

Unit in mm

## Performance Data:

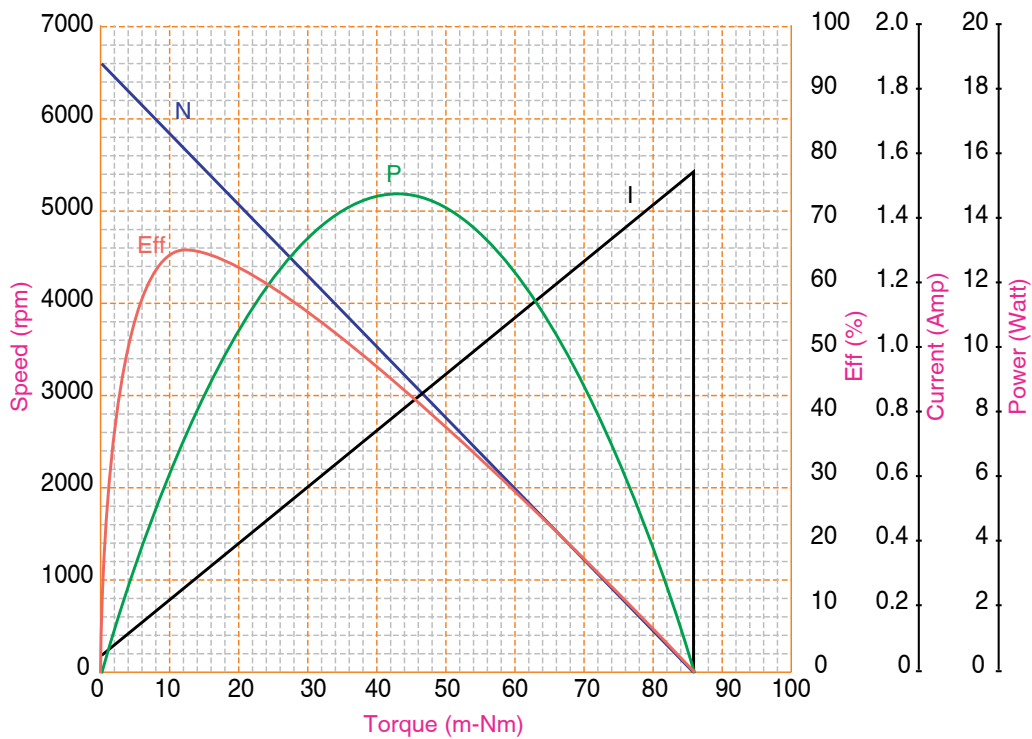

## Market

Building Automation & Security

## Application:



## Motor Characteristics:

Diameter	: 29.2 mm
Length	: 94.3 mm
Shaft Diameter	: 3.175 mm
Weight	: 158 g
Nominal Voltage	: 12 V
Torque Constant	: 15.569 m-Nm/A
Dynamic Resistance	: 1.079 Ohms
Motor Regulations	: 41.280 Rpm/m-Nm
Pole Number	: 5

## Standard Data:

Operation Temperature	: -10 — 55°C
Storage Temperature	: -20 — 100°C
Mounting	: Any position
Electrical Connection	: Terminal
Winding Temperature (Tmax)	: 180 °C
Direction of Rotation	: CW/CCW
Standards	: RoHS

## Electrical Performance:

	No Load	Stall	Max Eff	Max Power
Speed (Rpm)	6954		5997	3476
Current (A)	0.30	11.12	1.82	5.71
Torque (mNm)		168.53	23.67	84.26
Efficiency (%)			67.97	
Power			14.82	30.68

## Drawing:

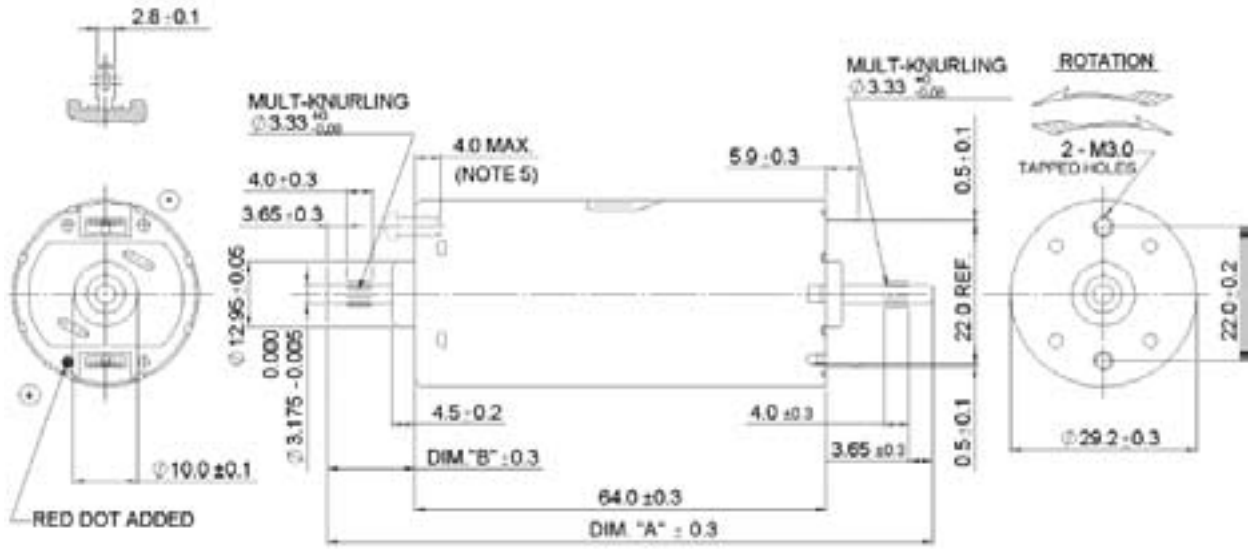

Unit in mm

## Performance Data:

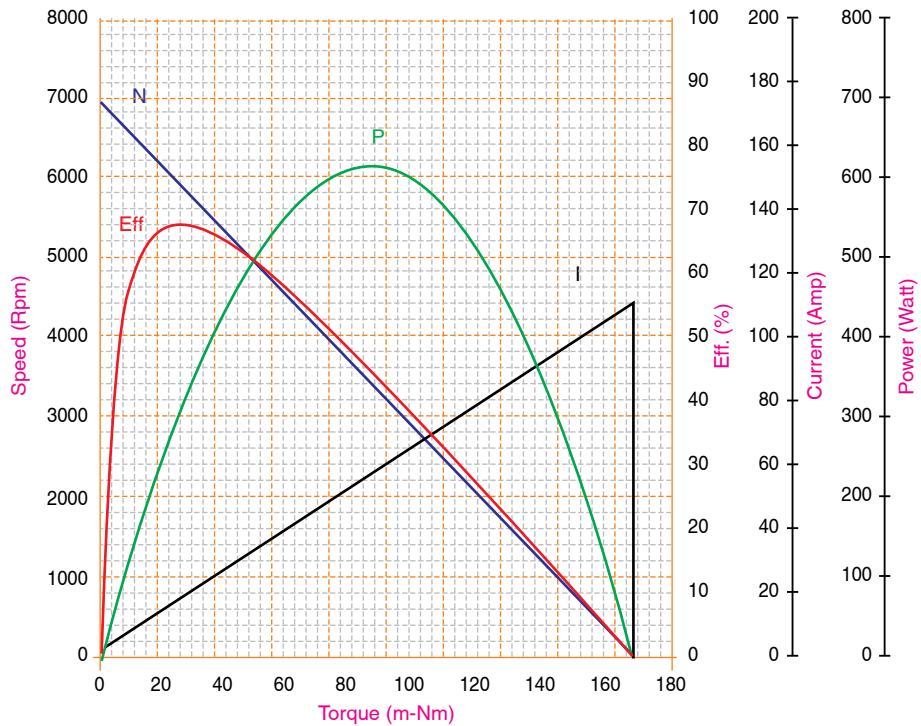

## Market

Home Appliances

## Application:

Hand Vacu-

## Motor Characteristics:

Diameter	: 35.8 mm
Length	: 50 mm
Shaft Diameter	: 3.175 mm
Weight	: 149 g
Nominal Voltage	: 9.6 V
Torque Constant	: 4.337 m-Nm/A
Dynamic Resistance	: 0.386 Ohms
Motor Regulations	: 210.955 Rpm/m-Nm
Pole Number	: 3

## Standard Data:

Operation Temperature	: -10 — 50°C
Storage Temperature	: -20 — 100°C
Mounting	: Any position
Electrical Connection	: Terminal
Power Output	: 36.1 W
Running Torque	: 20.1 mNm
Direction of Rotation	: CW
Standard	: RoHS

## Electrical Performance:

	No Load	Stall	Max Eff	Max Power
Speed (Rpm)	21400		17100	10700
Current (A)	1.54	24.88	6.18	13.2
Torque (mNm)		101.25	20.10	50.6
Efficiency (%)			60.82	
Output Power (W)			36.10	56.60



This #600 series motor is small, high speed and efficient, and has a long life. It has the leading position for use in portable hand vac applications



## Drawing:

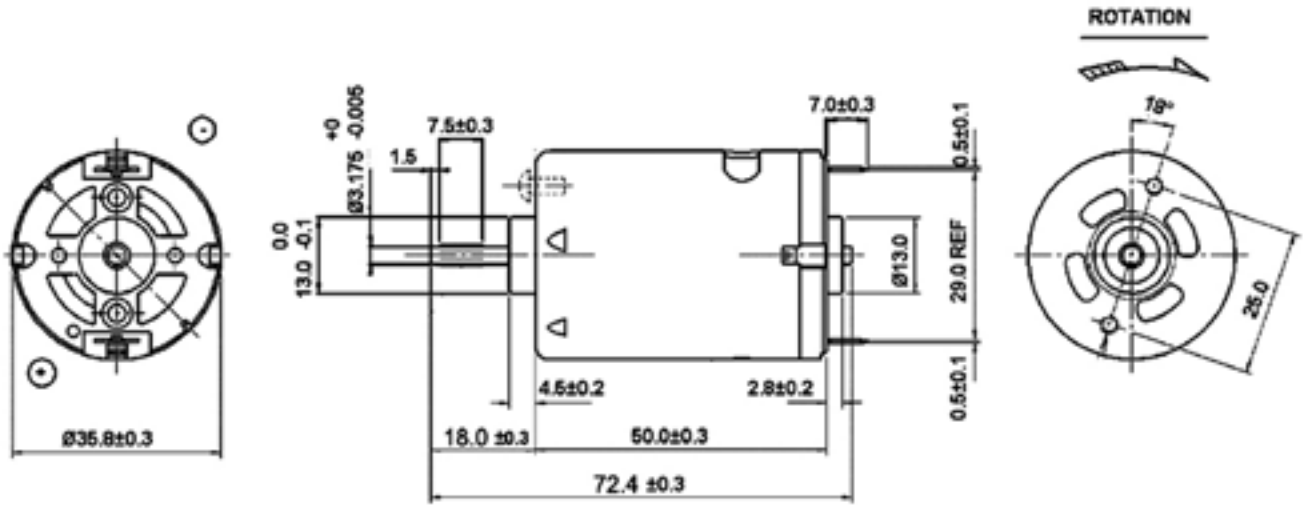

Unit in mm

## Performance Data:

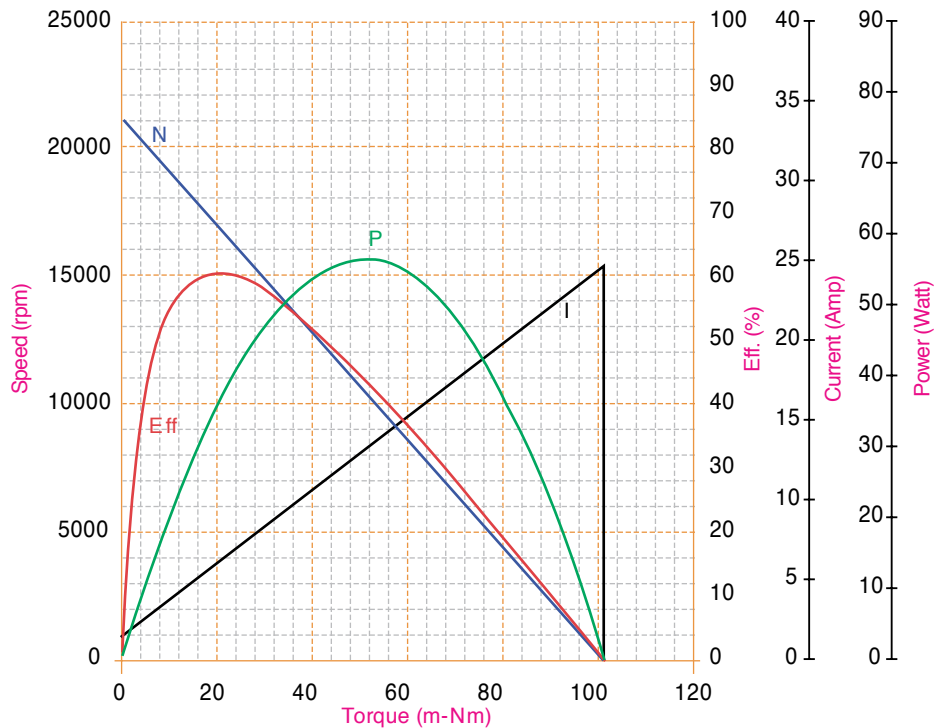

## Market

Home Appliances

## Application:

Hand Vacu-

## Motor Characteristics:

Diameter	: 35.8 mm
Length	: 50 mm
Shaft Diameter	: 3.175 mm
Weight	: 162 g
Nominal Voltage	: 4.8 V
Torque Constant	: 1.735 m-Nm/A
Dynamic Resistance	: 0.097 Ohms
Motor Regulations	: 354.137 Rpm/m-Nm
Pole Number	: 3



This #600 series motor is small, high speed and efficient, and has a long life. It has the leading position for use in portable hand vac. applications

## Standard Data:

Operation Temperature	: -10 — 50°C
Storage Temperature	: -20 — 100°C
Mounting	: Any position
Electrical Connection	: Terminal
Power Output	: 40.08 W
Running Torque	: 18.5 mNm
Direction of Rotation	: CW
Standard	: RoHS

## Electrical Performance:

	No Load	Stall	Max Eff	Max Power
Speed (Rpm)	27200		20700	13600
Current (A)	4.94	49.27	15.61	27.11
Torque (mNm)		76.92	18.5	38.46
Efficiency (%)			53.51	
Output Power (W)			40.08	54.83

## Drawing:

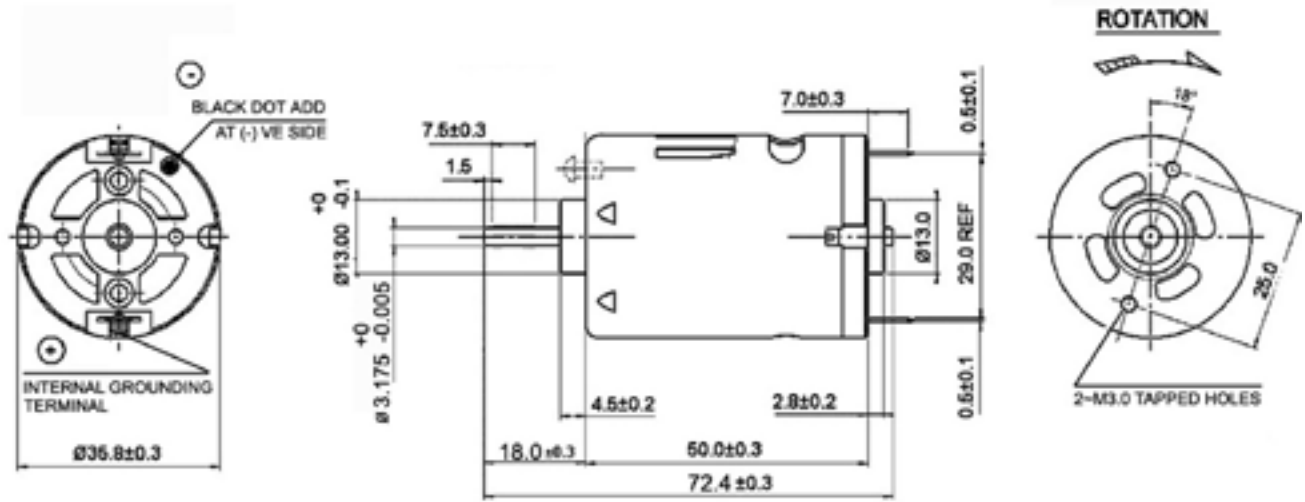

Unit in mm

## Performance Data:

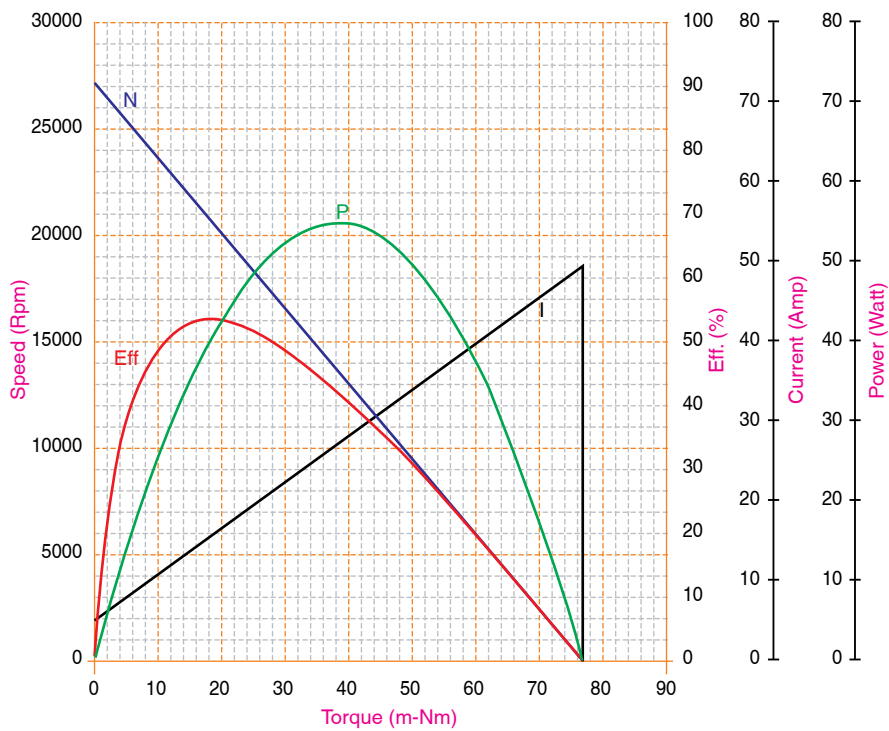

## Market

Home Appliances

## Application:

Hand Vacu-

## Motor Characteristics:

Diameter	: 35.8 mm
Length	: 50 mm
Shaft Diameter	: 3.175 mm
Weight	: 160 g
Nominal Voltage	: 7.2 V
Torque Constant	: 2.497 m-Nm/A
Dynamic Resistance	: 0.08 Ohms
Motor Regulations	: 138.203 Rpm/m-Nm
Pole Number	: 3



This #600 series motor is small, high speed and efficient, and has a long life. It has the leading position for use in portable hand vac applications

## Standard Data:

Operation Temperature	: -10 — 50°C
Storage Temperature	: -20 — 100°C
Mounting	: Any position
Electrical Connection	: Terminal
Power Output	: 78.47 W
Running Torque	: 32.62 mNm
Direction of Rotation	: CW
Standard	: RoHS

## Electrical Performance:

	No Load	Stall	Max Eff	Max Power
Speed (Rpm)	27500		23000	13700
Current (A)	3.39	87.88	17.25	45.63
Torque (mNm)		198.78	32.62	99.39
Efficiency (%)			63.18	
Output Power (W)			78.47	143.02

## Drawing:

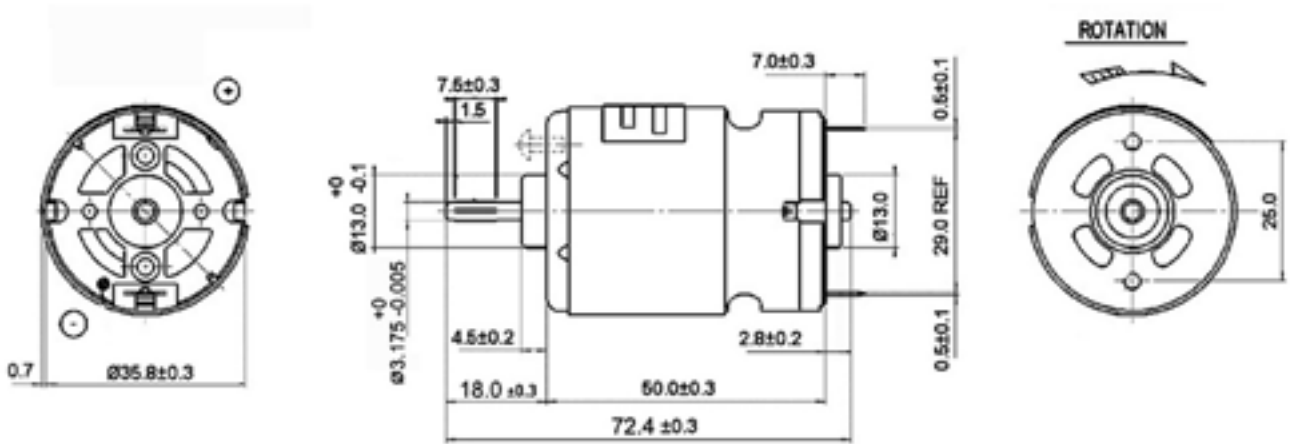

Unit in mm

## Performance Data:

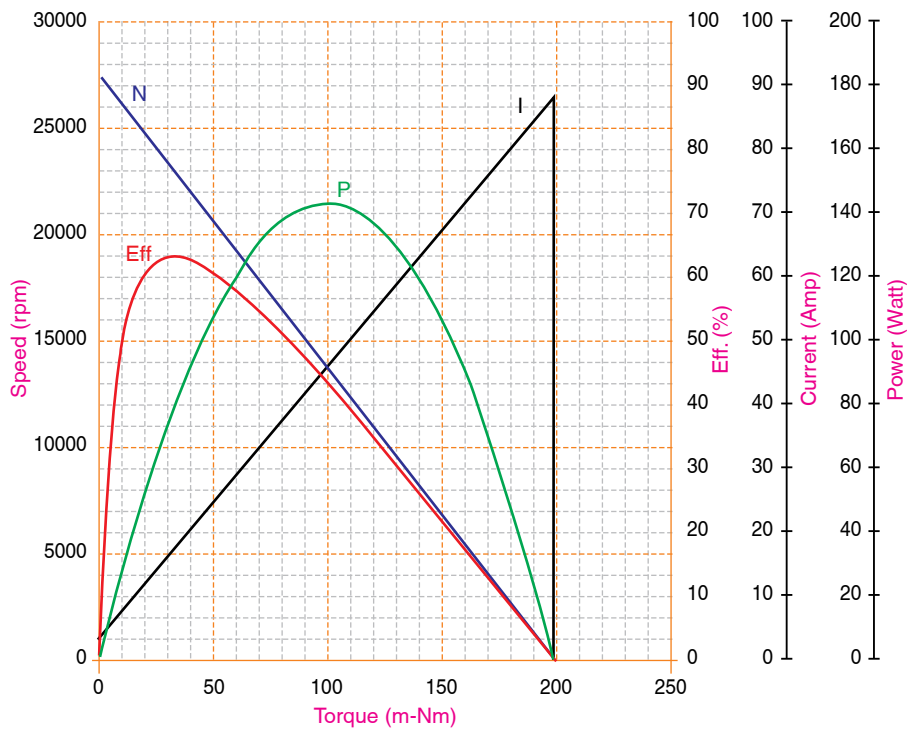

## Market

Leisure & Fitness

## Application:

Joystick



Motor for joystick application that has high power, low cogging, high stall torque, low starting voltage and longer life

## Motor Characteristics:

Diameter	: 35.8 mm
Length	: 50 mm
Shaft Diameter	: 3.175 mm
Weight	: 145.5 g
Nominal Voltage	: 24 V
Torque Constant	: 94.45 m-Nm/A
Dynamic Resistance	: 50.59 Ohms
Motor Regulations	: 54.60 Rpm/m-Nm
Pole Number	: 5

## Standard Data:

Operation Temperature	: -10 — 50°C
Storage Temperature	: -20 — 100°C
Mounting	: Any position
Electrical Connection	: Terminal
Winding Temperature (Tmax)	: 200 °C
Direction of Rotation	: CCW
Standards	: RoHS

## Electrical Performance:

	No Load	Stall	Max Eff	Max Power
Speed (Rpm)	2300		1900	1200
Current (A)	0.023	0.47	0.10	0.25
Torque (mNm)		42.63	7.67	21.32
Efficiency (%)			61.27	
Power (W)			1.53	2.60



## Market

Personal Care

## Application:

Hair Dryer



## Motor Characteristics:

Diameter	: 35.8 mm
Length	: 43.5 mm
Shaft Diameter	: 3.175 mm
Weight	: 150 g
Nominal Voltage	: 60 V
Frequency	: 60 Hz
Torque Constant	: 66.929 m-Nm/A
Dynamic Resistance	: 23.483 Ohms
Motor Regulations	: 52.195 Rpm/m-Nm
Pole Number	: 5

## Standard Data:

Operation Temperature	: -10 — 50°C
Storage Temperature	: -20 — 100°C
Mounting	: Any position
Electrical Connection	: Wire
Winding Temperature (Tmax)	: 180 °C
Direction of Rotation	: CCW
Standards	: RoHS

## Electrical Performance:

	No Load	Stall	Max Eff	Max Power
Speed (Rpm)	8660		7386	4330
Current (A)	0.076	2.555	0.441	1.316
Torque (mNm)		165.917	24.406	82.959
Efficiency (%)			71.4	
Power (W)			18.878	37.616



## Drawing:

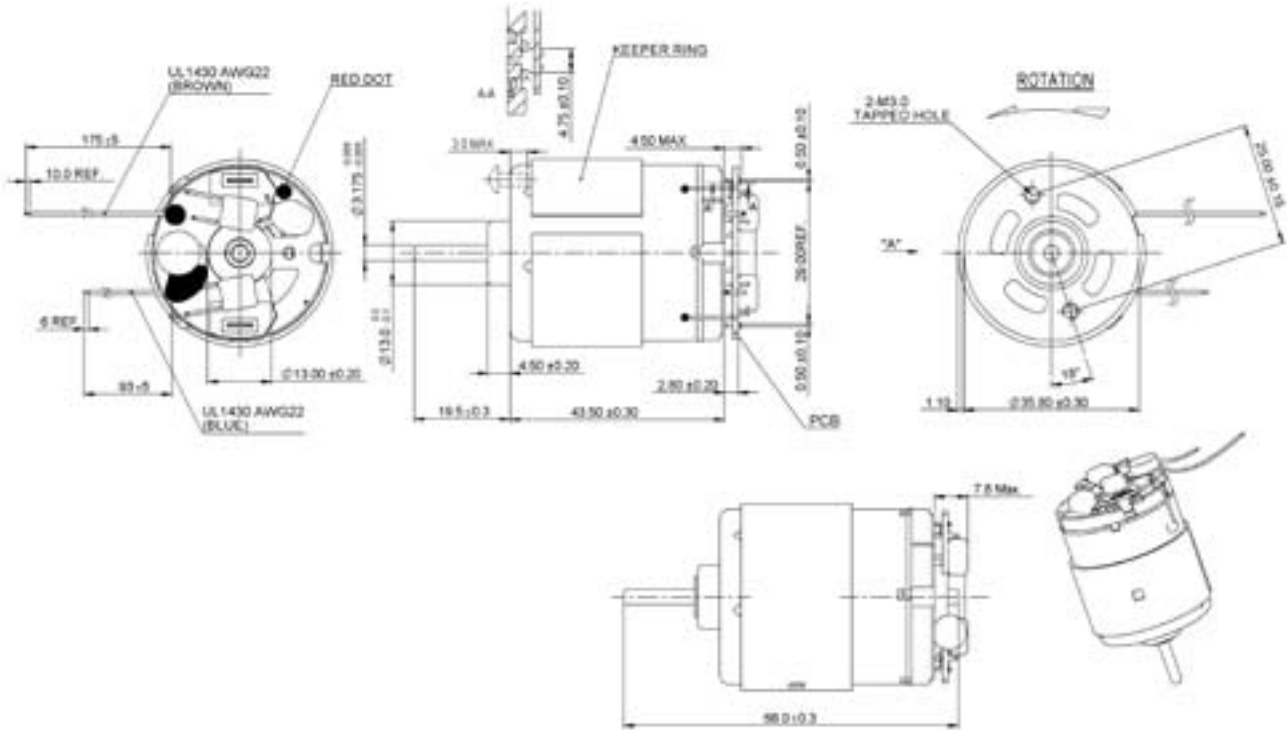

Unit in mm

## Performance Data:

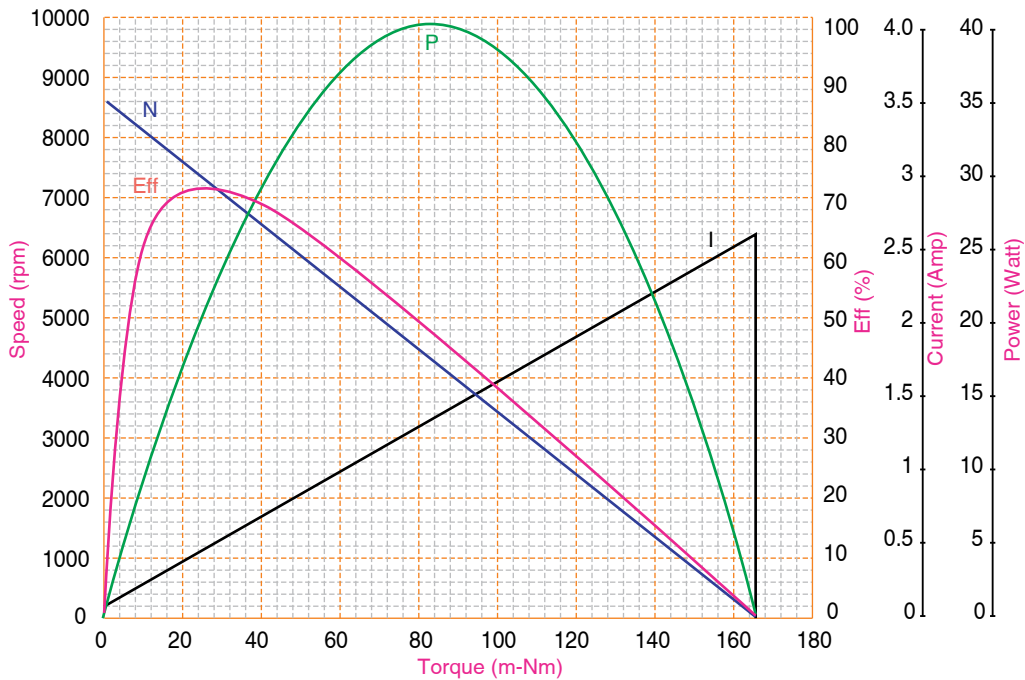

## Market

Leisure & Fitness

## Application:

Remote Control Car

## Motor Characteristics:

Diameter	: 35.8 mm
Length	: 50 mm
Shaft Diameter	: 3.175 mm
Weight	: 162 g
Nominal Voltage	: 7.2 V
Torque Constant	: 3.778 m-Nm/A
Dynamic Resistance	: 0.131 Ohms
Motor Regulations	: 79.496 Rpm/m-Nm
Pole Number	: 3



Specially designed motor for high power remote control car

## Standard Data:

Operation Temperature	: -10 — 50°C
Storage Temperature	: -20 — 100°C
Mounting	: Any position
Electrical Connection	: Terminal
Winding Temperature (Tmax)	: 180 °C
Direction of Rotation	: CCW
Standards	: RoHS
Remarks	: Capacitor

## Electrical Performance:

	No Load	Stall	Max Eff	Max Power
Speed (Rpm)	16316		13861	8042
Current (A)	1.16	54.98	8.82	28.20
Torque (mNm)		202.33	27.98	101.17
Efficiency (%)			63.94	
Power (W)			40.61	85.20



## Market

Power & Garden

## Application:

Drill

## Motor Characteristics:

Diameter	: 35.8 mm
Length	: 50 mm
Shaft Diameter	: 3.175 mm
Weight	: 176 g
Nominal Voltage	: 7.2 V
Torque Constant	: 3.187 m-Nm/A
Dynamic Resistance	: 0.119 Ohms
Motor Regulations	: 123.491 Rpm/m-Nm
Pole Number	: 3



The compact size, light weight and high power combination of this motor matches the requirements of the cordless drill

## Standard Data:

Operation Temperature	: -10 — 50°C
Storage Temperature	: -20 — 100°C
Mounting	: Any position
Electrical Connection	: Terminal
Power Consumption	: 88.56 W
Power Output	: 62.32 W
Running Torque	: 31.44 mNm
Direction of Rotation	: CCW
Standards	: RoHS

## Electrical Performance:

	No Load	Stall	Max Eff	Max Power
Speed (Rpm)	22900		19100	11500
Current (A)	2.43	60.73	12.16	31.58
Torque (mNm)		185.78	30.99	92.89
Efficiency (%)			70.87	
Output Power (W)			62.02	115.43

## Drawing:

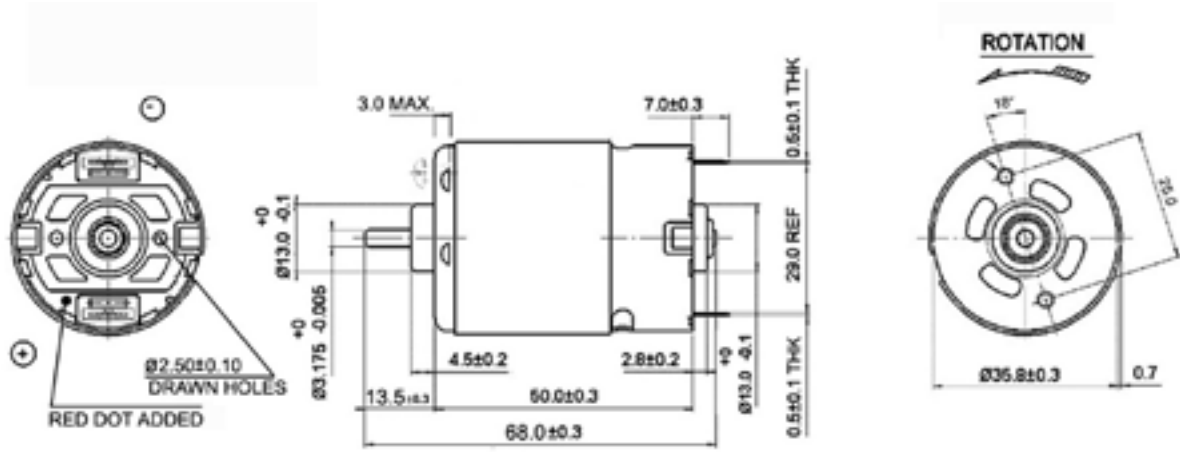

Unit in mm

## Performance Data:

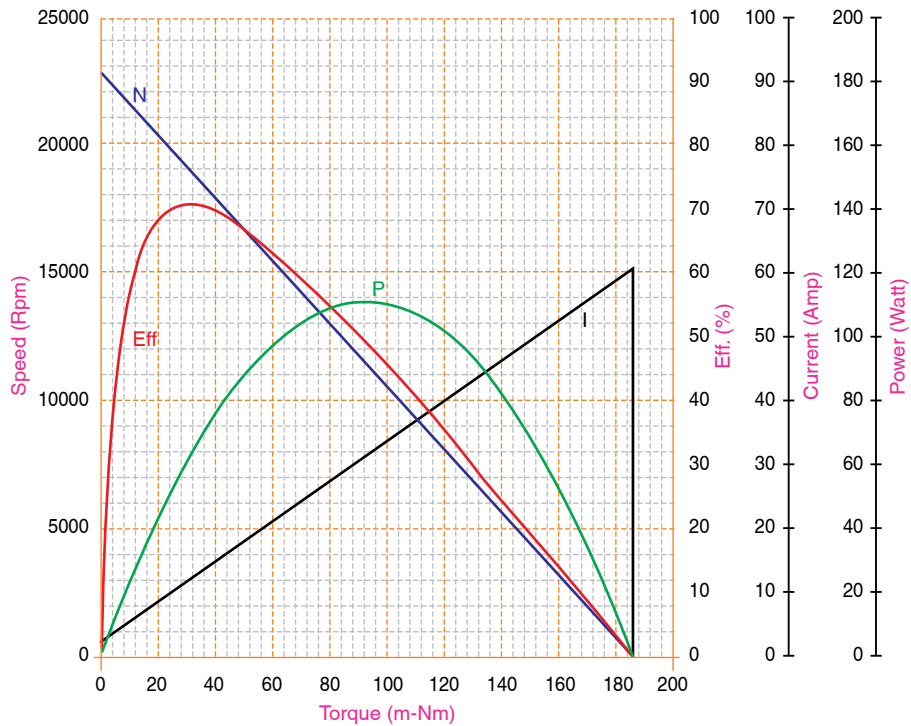

## Market

Leisure & Fitness

## Application:

Ride-on Car



The most widely-used motor for ride-on car toys

## Motor Characteristics:

Diameter	: 35.8 mm
Length	: 57 mm
Shaft Diameter	: 3.175 mm
Weight	: 242 g
Nominal Voltage	: 12 V
Torque Constant	: 6.684 m-Nm/A
Dynamic Resistance	: 0.197 Ohms
Motor Regulations	: 39.223 Rpm/m-Nm
Pole Number	: 3

## Standard Data:

Operation Temperature	: -10 — 50°C
Storage Temperature	: -20 — 100°C
Mounting	: Any position
Electrical Connection	: Terminal
Winding Temperature (Tmax)	: 180 °C
Direction of Rotation	: CCW
Standards	: RoHS

## Electrical Performance:

	No Load	Stall	Max Eff	Max Power
Speed (Rpm)	15694		13778	7847
Current (A)	1.18	61.04	8.49	31.11
Torque (mNm)		400.13	48.86	200.06
Efficiency (%)			69.19	
Power (W)			70.49	164.40

## Drawing:

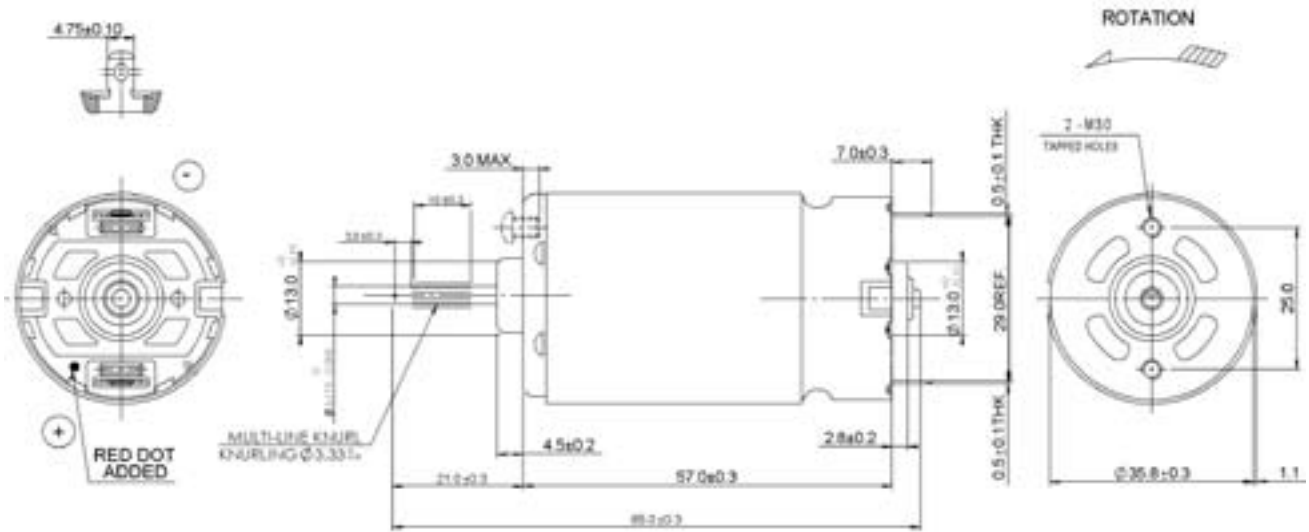

Unit in mm

## Performance Data:

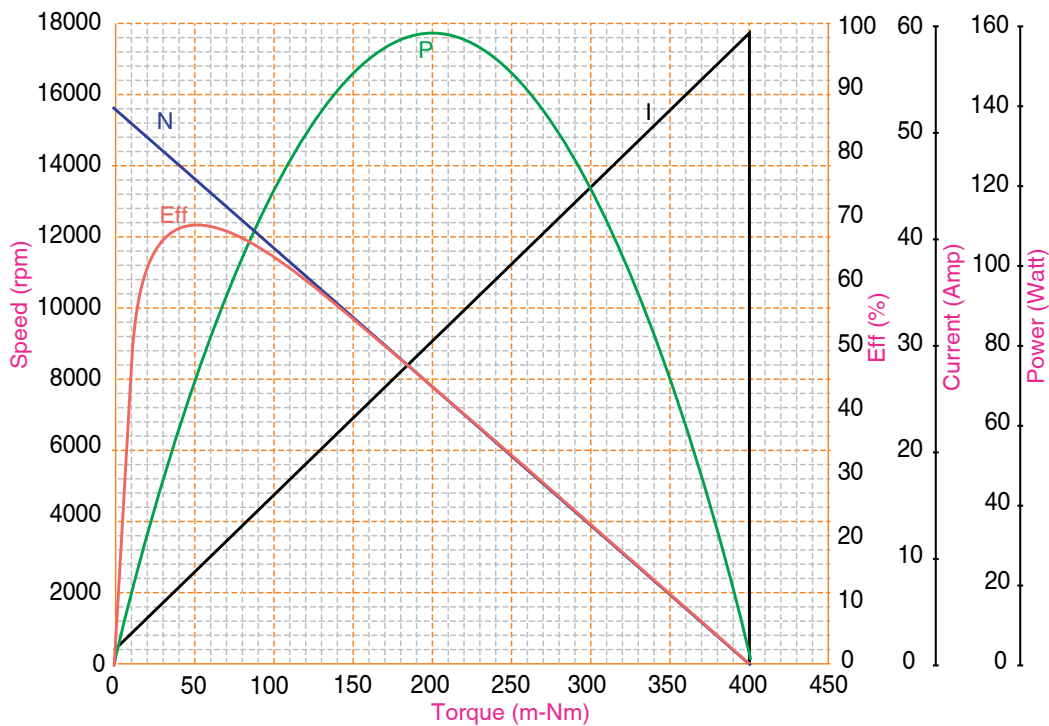

## Market

Power & Garden

## Application:

Drill

## Motor Characteristics:

Diameter	: 35.8 mm
Length	: 57 mm
Shaft Diameter	: 3.175 mm
Weight	: 230 g
Nominal Voltage	: 14.4 V
Torque Constant	: 6.229 m-Nm/A
Dynamic Resistance	: 0.157 Ohms
Motor Regulations	: 39.877 Rpm/m-Nm
Pole Number	: 3



The compact size, light weight and high power combination of this motor matches the requirements of the cordless drill

## Standard Data:

Operation Temperature	: -10 — 50°C
Storage Temperature	: -20 — 100°C
Mounting	: Any position
Electrical Connection	: Terminal
Power Consumption	: 173.14 W
Power Output	: 130.34 W
Running Torque	: 63.84 mNm
Direction of Rotation	: CCW
Standard	: RoHS

## Electrical Performance:

	No Load	Stall	Max Eff	Max Power
Speed (Rpm)	22300		19600	11200
Current (A)	1.84	91.76	12.99	46.8
Torque (mNm)		560.1	69.48	280.05
Efficiency (%)			76.1	
Output Power (W)			142.40	327.64



## Drawing:

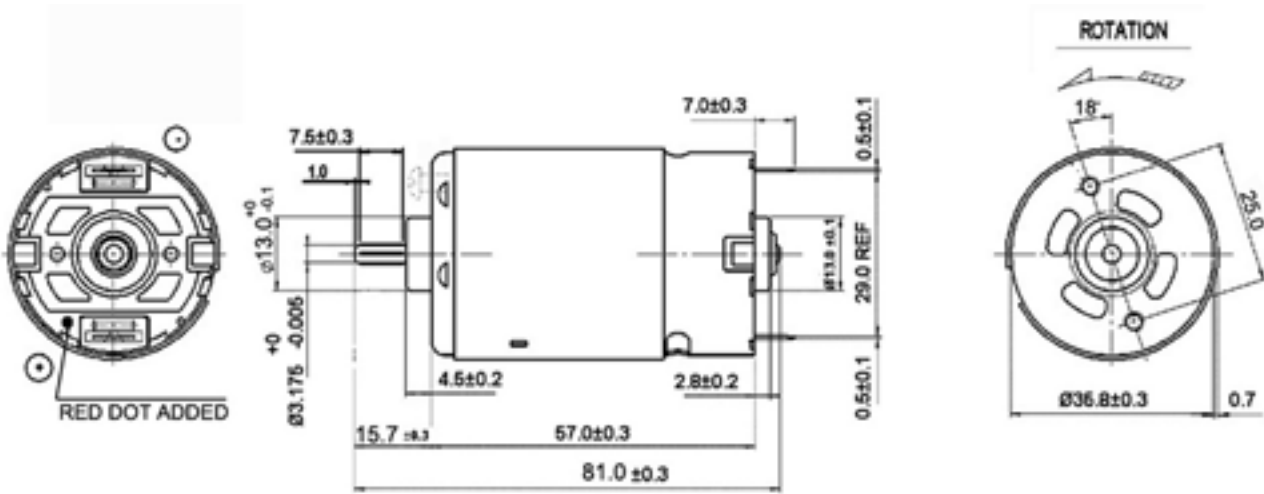

Unit in mm

## Performance Data:

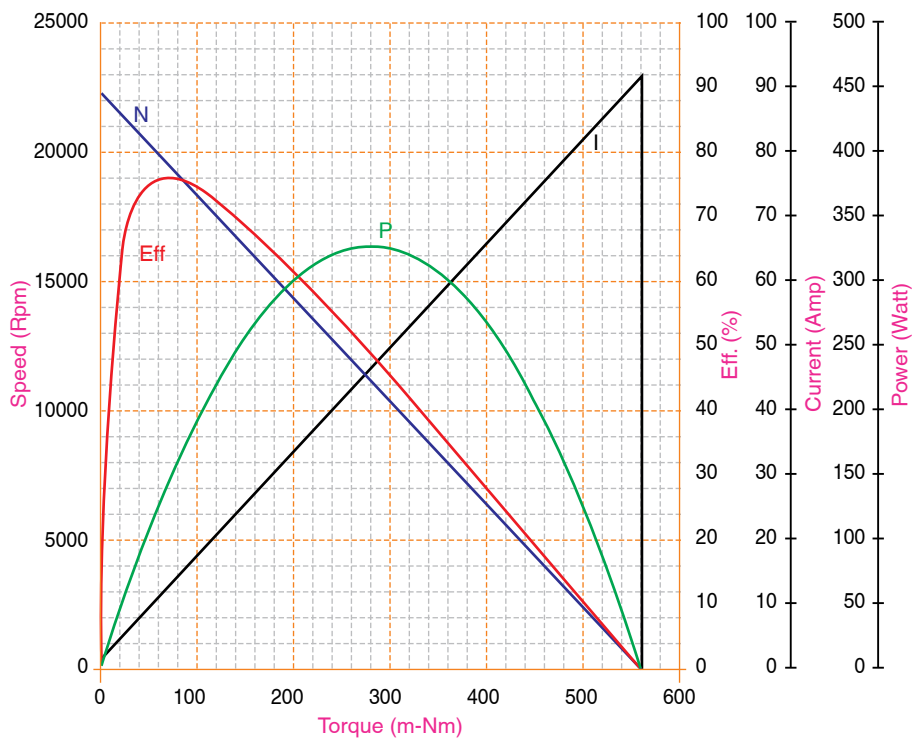

## Market

Leisure & Fitness

## Application:

Ride-on Car



Specially designed for high power ride on car toys

## Motor Characteristics:

Diameter	: 35.8 mm
Length	: 65 mm
Shaft Diameter	: 3.175 mm
Weight	: 261 g
Nominal Voltage	: 6 V
Torque Constant	: 3.811 m-Nm/A
Dynamic Resistance	: 0.072 Ohms
Motor Regulations	: 47.045 Rpm/m-Nm
Pole Number	: 3

## Standard Data:

Operation Temperature	: -10 — 50°C
Storage Temperature	: -20 — 100°C
Mounting	: Any position
Electrical Connection	: Terminal
Winding Temperature (Tmax)	: 180 °C
Direction of Rotation	: CW
Standards	: RoHS
Remarks	: Capacitor

## Electrical Performance:

	No Load	Stall	Max Eff	Max Power
Speed (Rpm)	14500		12185	7250
Current (A)	3.03	83.91	15.95	43.47
Torque (mNm)		308.22	49.22	154.11
Efficiency (%)			65.64	
Power (W)			62.80	117.00

## Drawing:

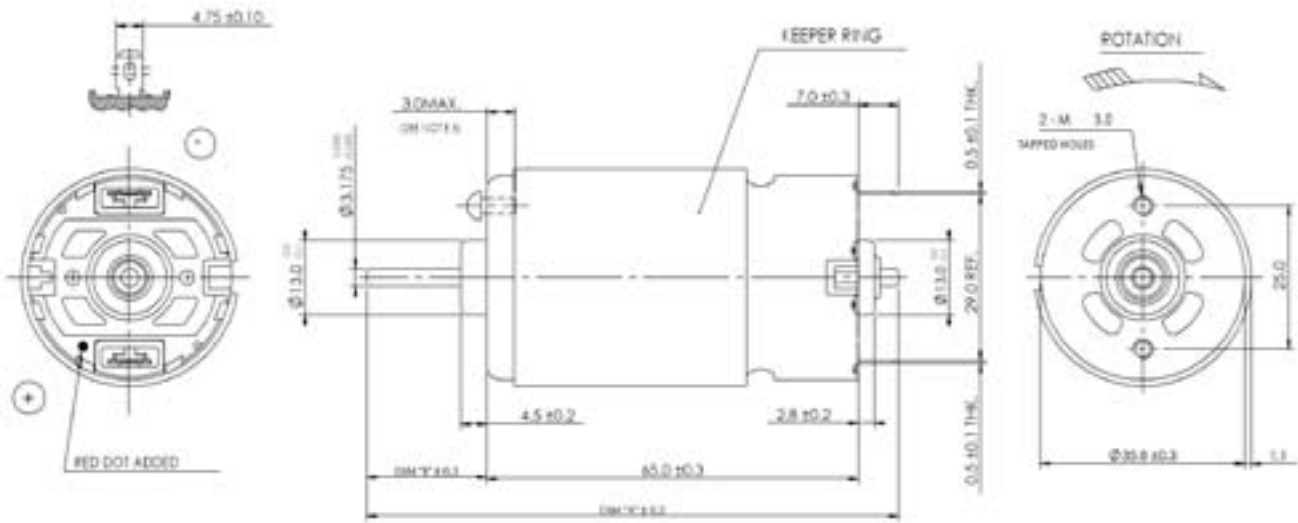

Unit in mm

## Performance Data:



## Market

Leisure & Fitness

## Application:

Joystick



Motor for joystick application that has high power, low cogging, high stall torque, low starting voltage and longer life

## Motor Characteristics:

Diameter	: 35.8 mm
Length	: 57 mm
Shaft Diameter	: 3.175 mm
Weight	: 203.1 g
Nominal Voltage	: 24 V
Torque Constant	: 123.678 m-Nm/A
Dynamic Resistance	: 45.425 Ohms
Motor Regulations	: 28.836 Rpm-m/Nm
Pole Number	: 5

## Standard Data:

Operation Temperature	: -10 — 55°C
Storage Temperature	: -20 — 100°C
Mounting	: Any position
Electrical Connection	: Terminal
Winding Temperature (Tmax)	: 200 °C
Direction of Rotation	: CW/CCW
Standards	: RoHS

## Electrical Performance:

	No Load	Stall	Max Eff	Max Power
Speed (Rpm)	1800		1500	900
Current (A)	0.026	0.528	0.116	0.277
Torque (mNm)		62.170	11.228	31.09
Efficiency (%)			61.80	
Power (W)			1.727	2.917

## Drawing:

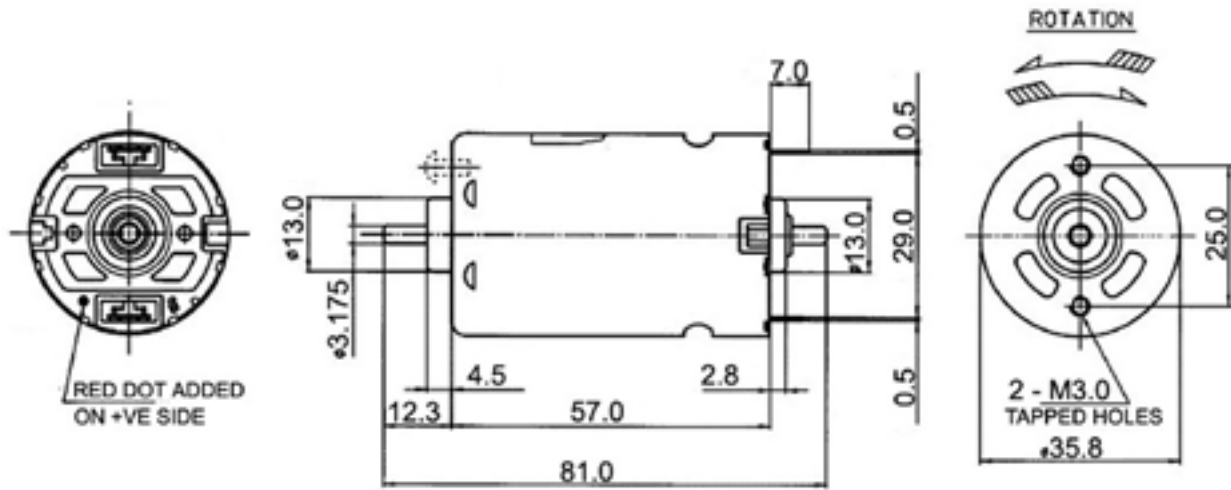

Unit in mm

## Performance Data:

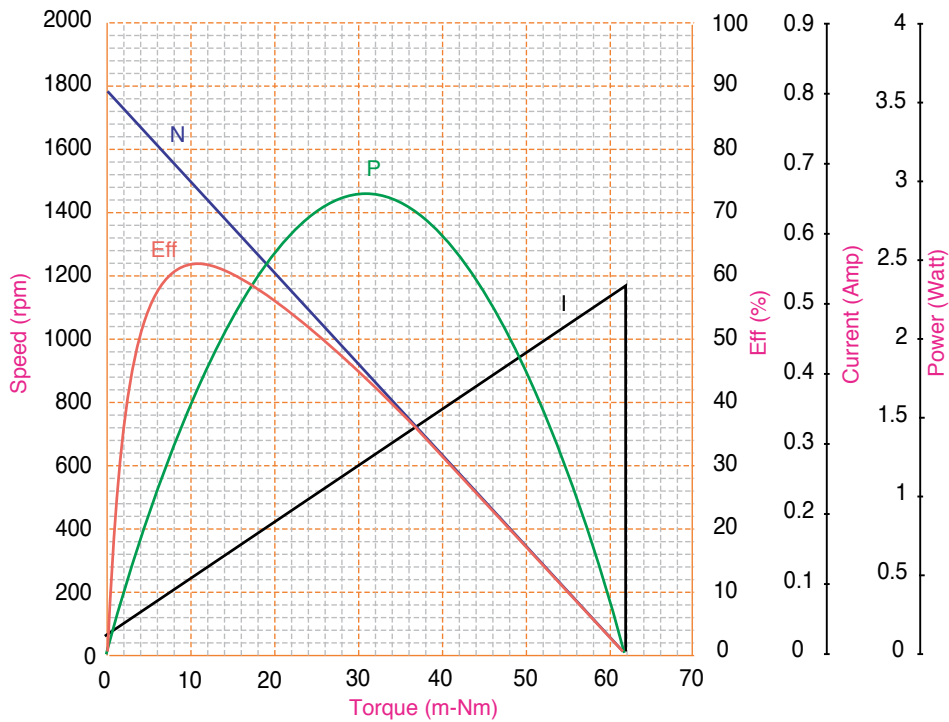

## Market

Business Machines

## Application:

Printer



Motor with low peak-to-peak cogging for smoother printing operation of high-end photo printers, is designed for printer carriage application.

## Motor Characteristics:

Diameter	: 35.8 mm
Length	: 57 mm
Shaft Diameter	: 3.175 mm
Weight	: 235 g
Nominal Voltage	: 23 V
Torque Constant	: 56.966 m-Nm/A
Dynamic Resistance	: 9.787 Ohms
Motor Regulations	: 28.927 Rpm/m-Nm
Pole Number	: 5

## Standard Data:

Operation Temperature	: -10 — 55°C
Storage Temperature	: -20 — 100°C
Mounting	: Any position
Electrical Connection	: Terminal
Winding Temperature (Tmax)	: 130 °C
Direction of Rotation	: CCW
Standards	: RoHS
Remarks	: Varistor

## Electrical Performance:

	No Load	Stall	Max Eff	Max Power (W)
Speed (Rpm)	3735		3100	1900
Current (A)	0.082	2.350	0.440	1.216
Torque (mNm)		129.183	20.37	64.592
Efficiency (%)			66.36	
Power (W)			6.713	12.633

## Drawing:

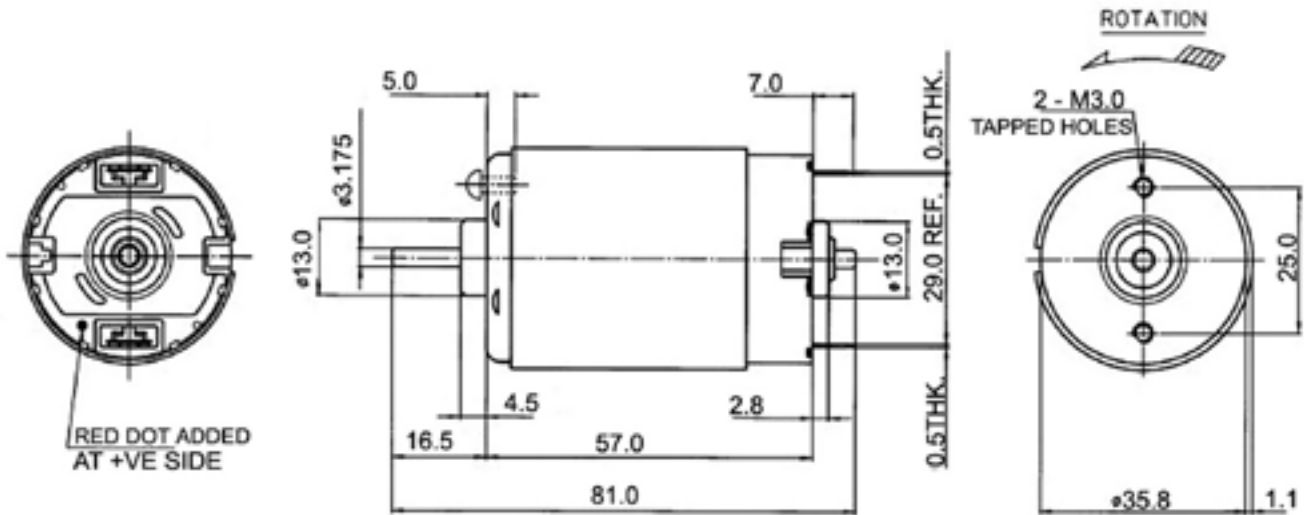

Unit in mm

## Performance Data:

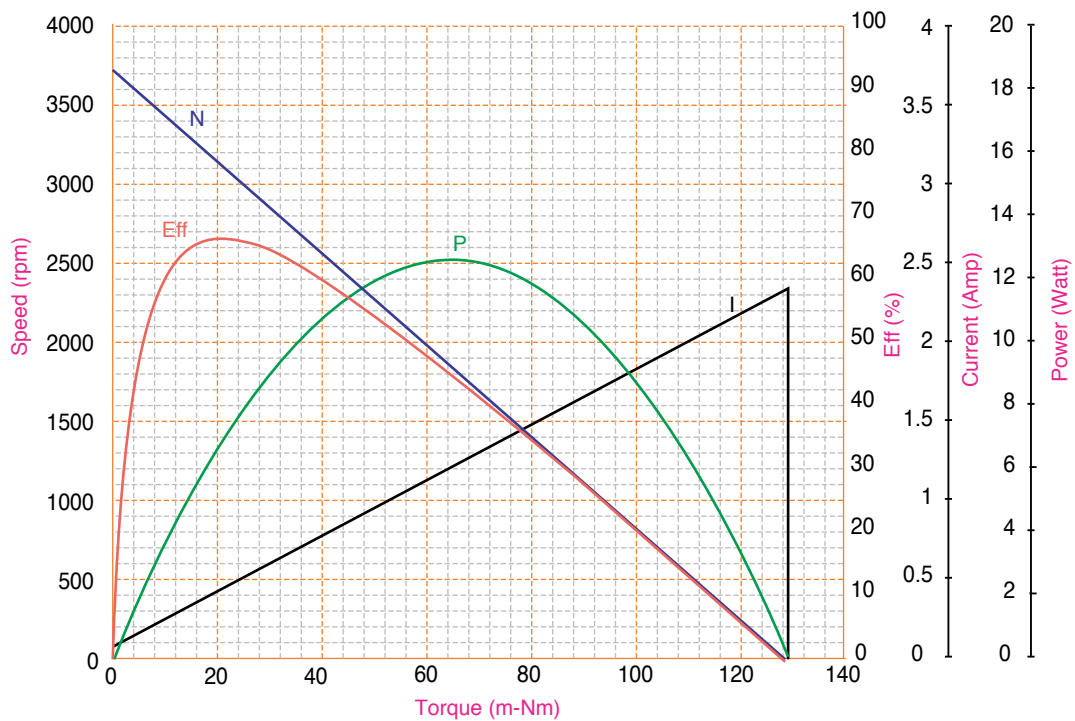

## Market

Home Appliances

## Application:

Hand Vacu-

## Motor Characteristics:

Diameter	: 35.8 mm
Length	: 57 mm
Shaft Diameter	: 3.17 mm
Weight	: 192 g
Nominal Voltage	: 12 V
Torque Constant	: 4.524 m-Nm/A
Dynamic Resistance	: 0.185 Ohms
Motor Regulations	: 90.891 Rpm/m-Nm
Pole Number	: 5



This #600 series motor is small, high speed and efficient, and has a long life. It has the leading position for use in portable hand vac applications

## Standard Data:

Operation Temperature	: -10 — 50°C
Storage Temperature	: -20 — 100°C
Mounting	: Any position
Electrical Connection	: Terminal
Power Output	: 99.56 W
Running Torque	: 43.59 mNm
Direction of Rotation	: CCW
Standard	: RoHS

## Electrical Performance:

	No Load	Stall	Max Eff	Max Power
Speed (Rpm)	25800		21800	12900
Current (A)	2.14	64.79	11.78	33.47
Torque (mNm)		283.45	43.59	141.73
Efficiency (%)			70.46	
Output Power (W)			99.56	191.26



## Drawing:

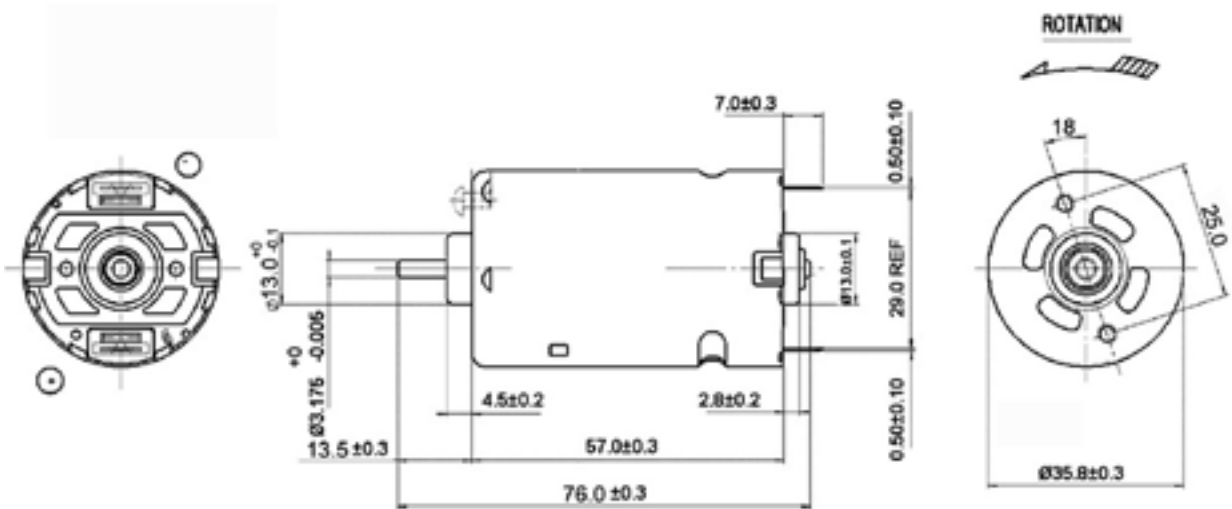

Unit in mm

## Performance Data:

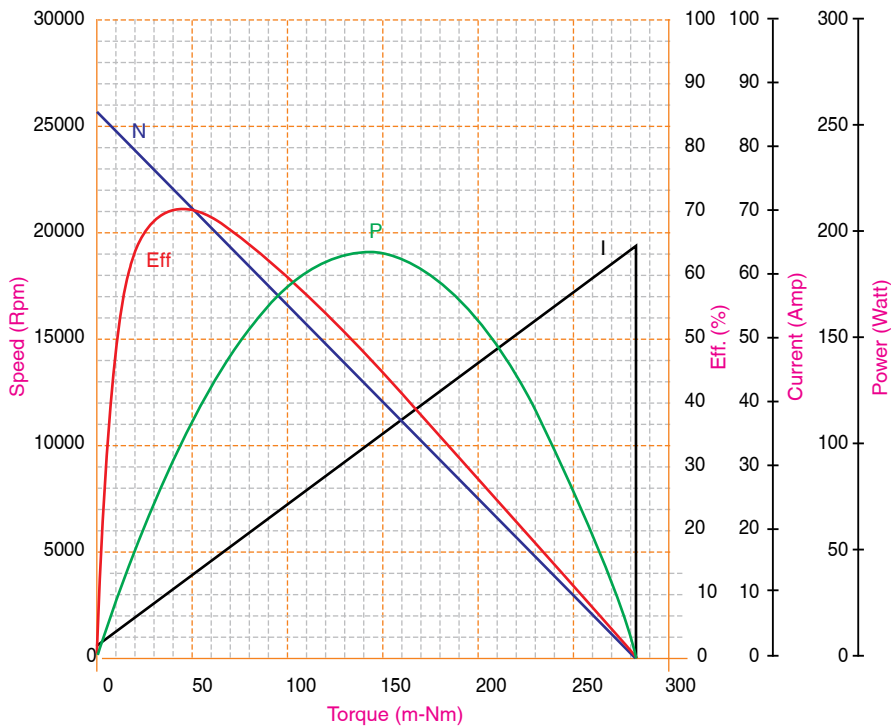

## Market

Power & Garden

## Application:

Screw Driver

## Motor Characteristics:

Diameter	: 42.3 mm
Length	: 66 mm
Shaft Diameter	: 5.005 mm
Weight	: 391 g
Nominal Voltage	: 18 V
Torque Constant	: 8.399 m-Nm/A
Dynamic Resistance	: 0.177 Ohms
Motor Regulations	: 25.105 Rpm/m-Nm
Pole Number	: 5

## Standard Data:

Operation Temperature	: -10 — 50°C
Storage Temperature	: -20 — 100°C
Mounting	: Any position
Electrical Connection	: Leadwire
Power Consumption	: 254 W
Power Output	: 185.075 W
Running Torque	: 98.03 cNm
Direction of Rotation	: CCW
Stadard	: RoHS

## Electrical Performance:

	No Load	Stall	Max Eff	Max Power
Speed (Rpm)	21000		18400	10500
Current (A)	2.017	101.61	14.315	51.813
Torque (mNm)		836.49	103.29	418.24
Efficiency (%)			77.3	
Output Power (W)			199.183	406.068



This motor is developed for high torque and efficiency required for cordless power tool applications.



## Market

Power & Garden

## Application:

Drill

## Motor Characteristics:

Diameter	: 42.2 mm
Length	: 60 mm
Shaft Diameter	: 5.005 mm
Weight	: 279 g
Nominal Voltage	: 12 V
Torque Constant	: 5.083 m-Nm/A
Dynamic Resistance	: 0.095 Ohms
Motor Regulations	: 33.604 Rpm/m-Nm
Pole Number	: 5

## Standard Data:

Operation Temperature	: -10 — 50°C
Storage Temperature	: -20 — 100°C
Mounting	: Any position
Electrical Connection	: Terminal
Power Consumption	: 280.62 W
Power Output	: 179.73 W
Running Torque	: 96.97 mNm
Direction of Rotation	: CCW
Standard	: RoHS

## Electrical Performance:

	No Load	Stall	Max Eff	Max Power
Speed (Rpm)	21000		17700	10500
Current (A)	4.31	126.98	23.39	65.64
Torque (mNm)		623.48	96.97	311.74
Efficiency (%)			64.05	
Output Power (W)			179.73	342.12



This motor is developed for high torque and efficiency required for cordless power tool applications

## Drawing:

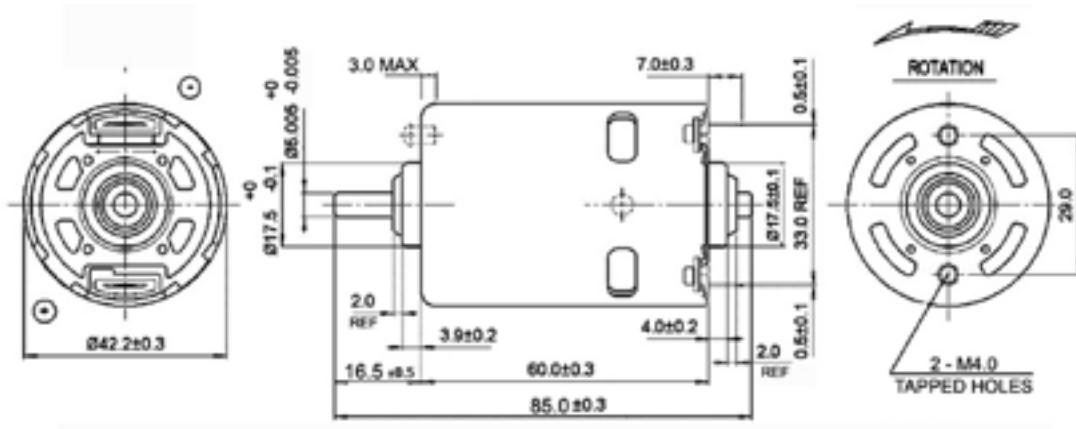

Unit in mm

## Performance Data:

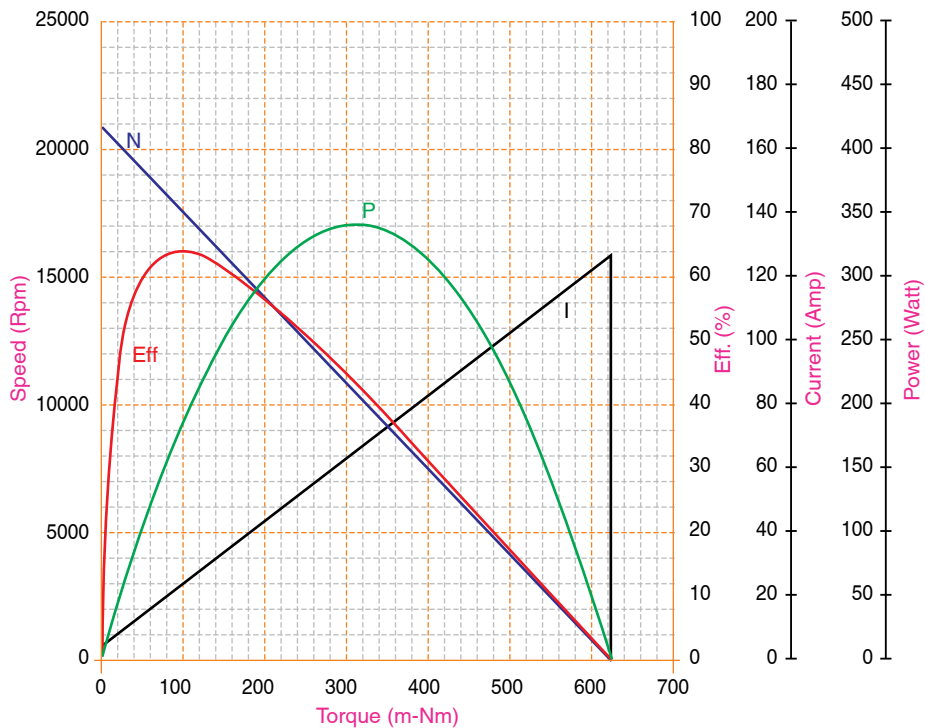

## Market

Power & Garden

## Application:

Impact Driver

## Motor Characteristics:

Diameter	: 48 mm
Length	: 65 mm
Shaft Diameter	: 4.005 mm
Weight	: 320 g
Nominal Voltage	: 14.4 V
Torque Constant	: 6.5 m-Nm/A
Dynamic Resistance	: 0.115 Ohms
Motor Regulations	: 25.543 Rpm/m-Nm
Pole Number	: 5



This motor is developed for high torque and efficiency required for cordless power tool applications

## Standard Data:

Operation Temperature	: -10 — 50°C
Storage Temperature	: -20 — 100°C
Mounting	: Any position
Electrical Connection	: Leadwire
Power Consumption	: 296.4 W
Power Output	: 188.8 W
Running Torque	: 106.8 cNm
Direction of Rotation	: CCW
Standard	: RoHS

## Electrical Performance:

	No Load	Stall	Max Eff	Max Power
Speed (Rpm)	20120		17134	10060
Current (A)	3.8	124.99	21.78	64.39
Torque (mNm)		787.72	116.91	393.86
Efficiency (%)			66.9	
Output Power (W)			209.86	415.1

## Drawing:

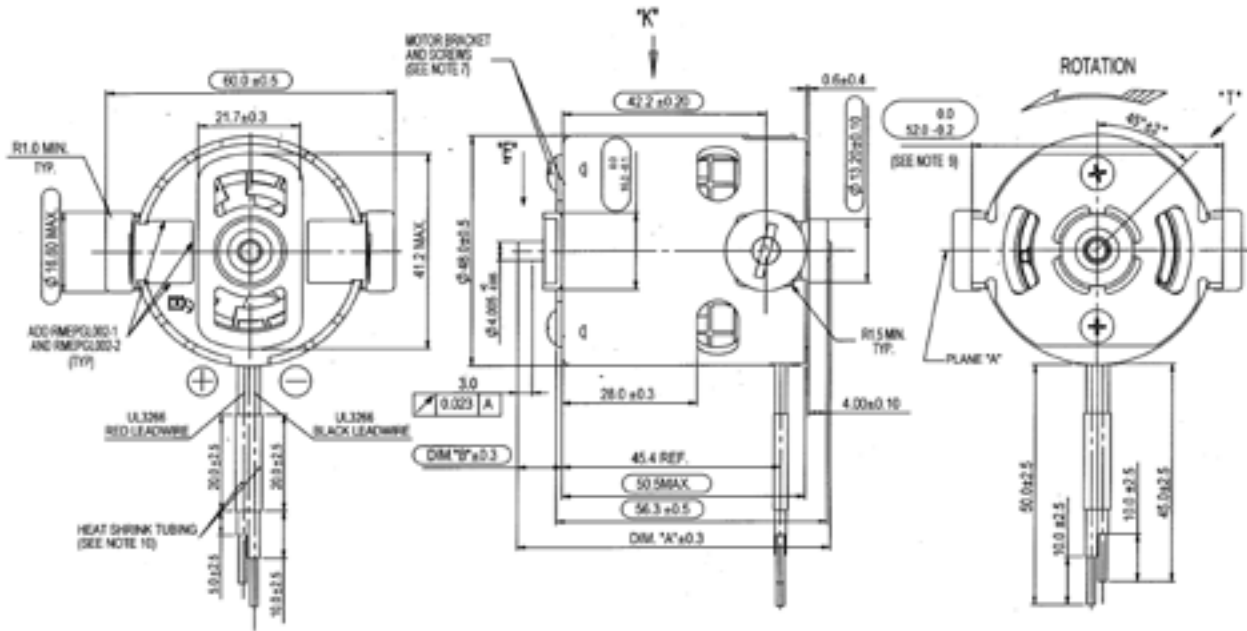

Unit in mm

## Performance Data:

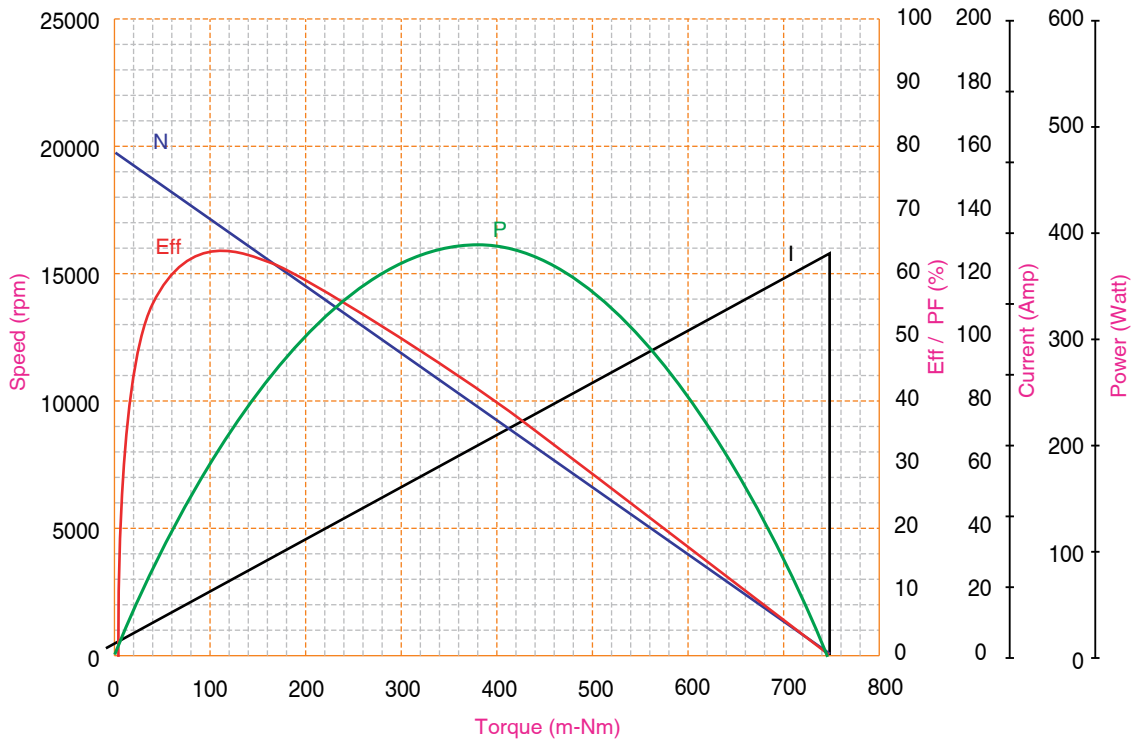

## Market

Power & Garden

## Application:

Drill

## Motor Characteristics:

Diameter	: 48 mm
Length	: 68 mm
Shaft Diameter	: 5.005 mm
Weight	: 455 g
Nominal Voltage	: 18 V
Torque Constant	: 7.985 m-Nm/A
Dynamic Resistance	: 0.101 Ohms
Motor Regulations	: 14.8888
Pole Number	: 7



Having a long life and durability, this motor offers great performance for cordless professional power tool applications

## Standard Data:

Operation Temperature	: -10 — 50°C
Storage Temperature	: -20 — 100°C
Mounting	: Any position
Electrical Connection	: Terminal
Power Consumption	: 463.6 W
Power Output	: 333.3 W
Running Torque	: 175.9
Direction of Rotation	: CCW
Standards	: RoHS

## Electrical Performance:

	No Load	Stall	Max Eff	Max Power
Speed (Rpm)	20700		18100	10400
Current (A)	3.73	177.877	25.758	90.803
Torque (mNm)		1390.6	175.9	695.31
Efficiency (%)			71.88	
Power			333.27	754.061



## Drawing:

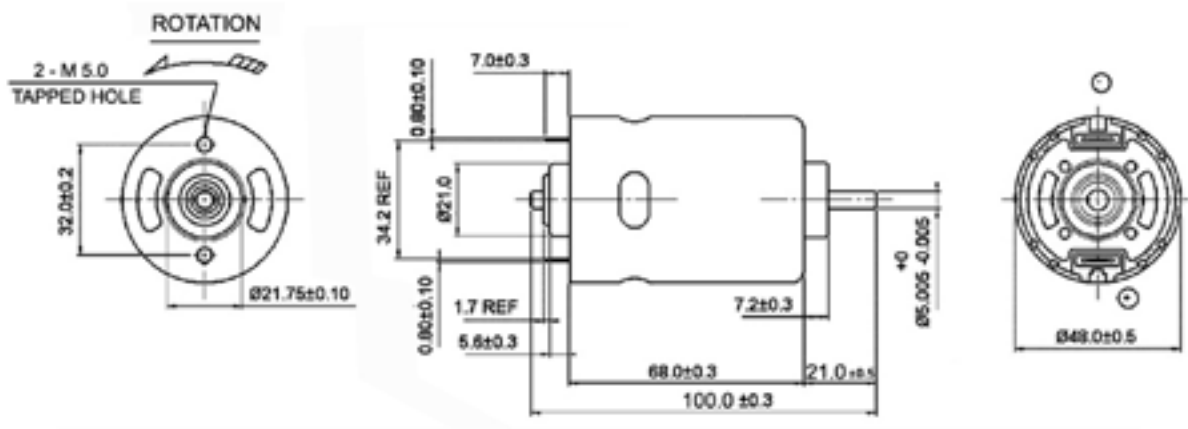

Unit in mm

## Performance Data:

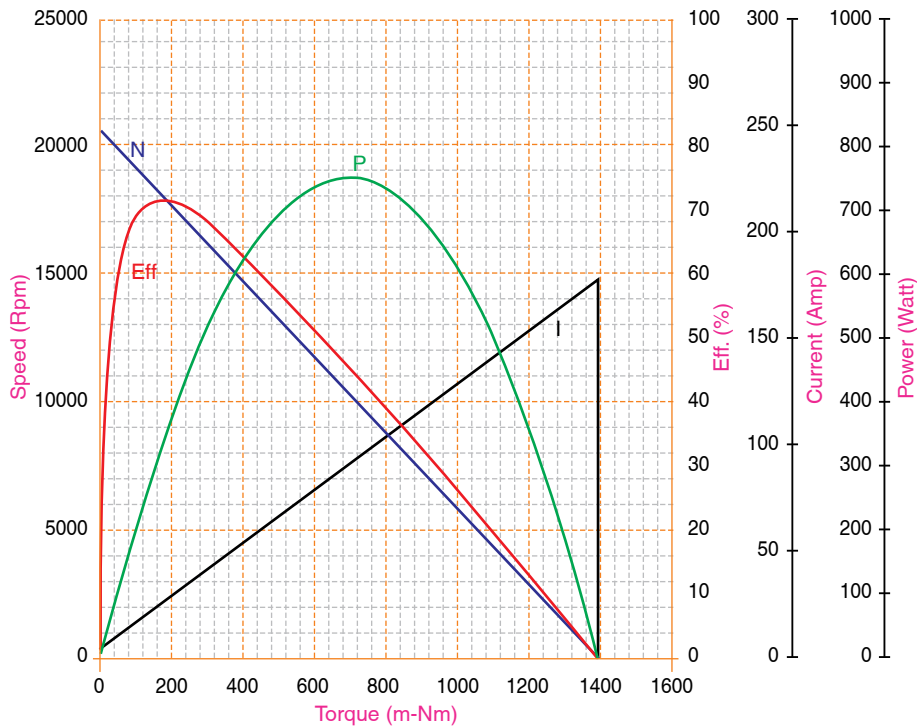

## Market

Leisure & Fitness

## Application:

Outboard Marine, Recreational Vehicles, Yacht,



This motor is designed for bilge pump applications

## Motor Characteristics:

Diameter	: 51.9 mm
Length	: 85 mm
Shaft Diameter	: 6.355 mm
Weight	: 645 g
Nominal Voltage	: 12 V
Torque Constant	: 11.720 m-Nm/A
Dynamic Resistance	: 0.112 Ohms
Motor Regulations	: 7.522 Rpm/m-Nm
Pole Number	: 7

## Standard Data:

Operation Temperature	: -10 — 50°C
Storage Temperature	: -20 — 100°C
Mounting	: Any position
Electrical Connection	: Terminal
Power Consumption	: 155.0 W
Power Output	: 116.0 W
Running Torque	: 133.0 mNm
Direction of Rotation	: CCW
Standard	: RoHS

## Electrical Performance:

	No Load	Stall	Max Eff	Max Power
Speed (Rpm)	9323		8316	4660
Current (A)	1.57	107.37	13.0	54.47
Torque (mNm)		1239.85	133.88	619.93
Efficiency (%)			74.79	
Output Power (W)			116.64	302.62

## Drawing:

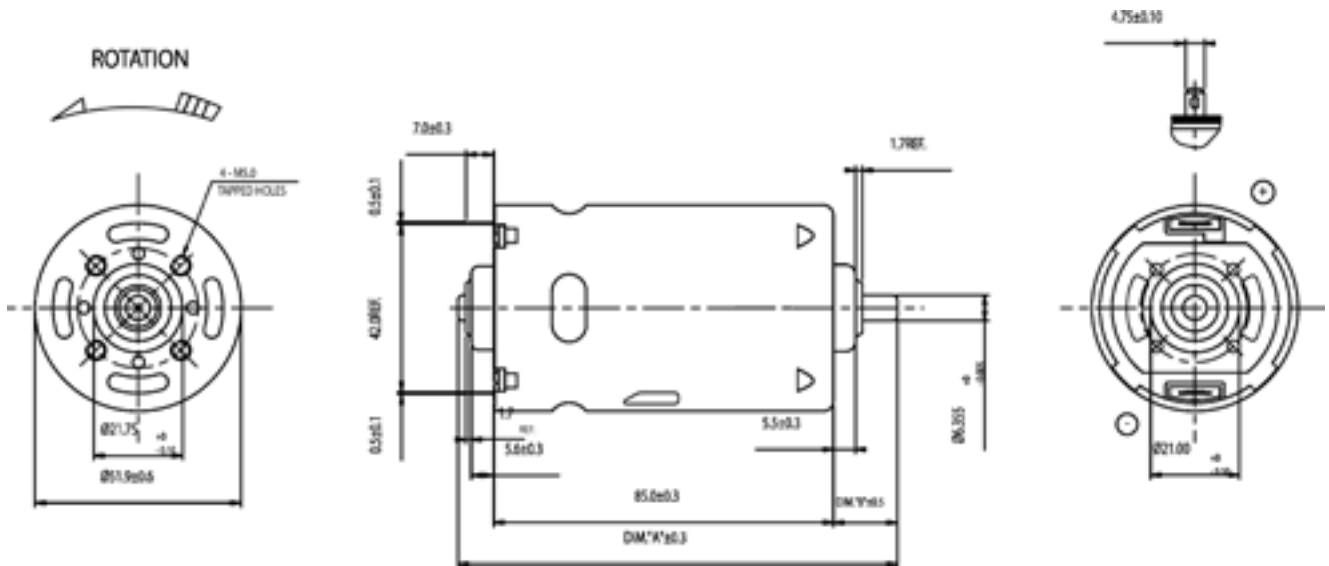

Unit in mm

## Performance Data:

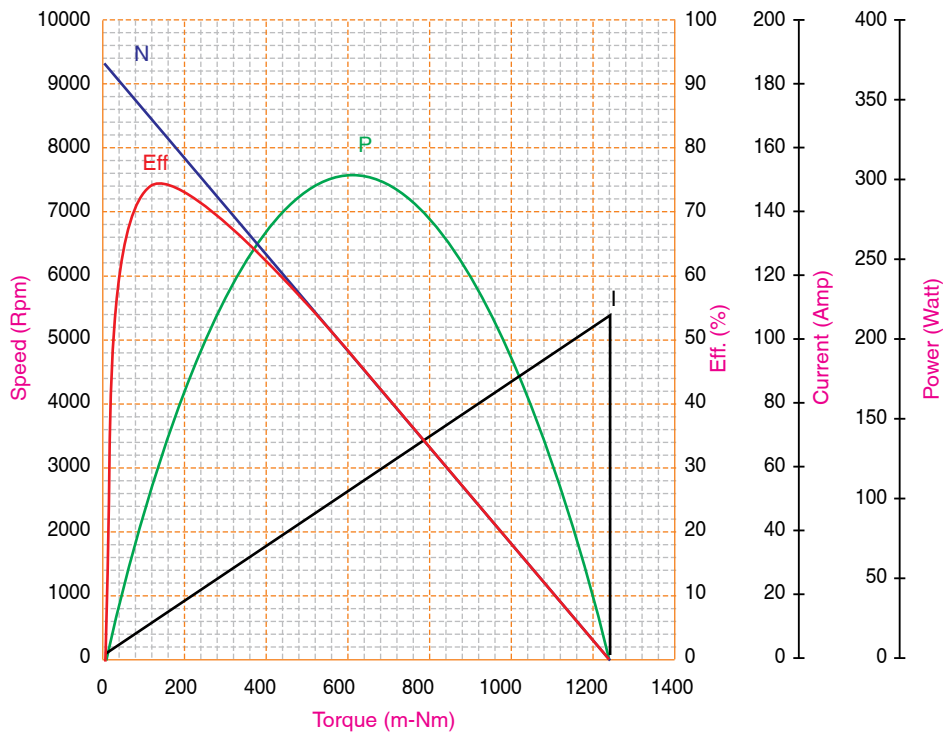

## Market:

Power & Garden

## Application:

Circular Saw, Reciprocal Saw

## Motor Characteristics:

Diameter	: 80 mm
Length	: 82.4 mm
Shaft Diameter	: 8.005 mm
Weight	: 720 g
Nominal Voltage	: 19.2 V
Torque Constant	: 10.953 m-Nm/A
Dynamic Resistance	: 0.135 Ohms
Motor Regulations	: 12.776 Rpm/m-Nm
Pole Number	: 12

## Standard Data:

Operation Temperature	: -10 — 50°C
Storage Temperature	: -20 — 100°C
Mounting	: Any position
Electrical Connection	: Leadwire
Power Consumption	: 672 W
Power Output	: 456 W
Running Torque	: 3300 gcm
Direction of Rotation	: CCW
Standards	: RoHS

## Electrical Performance:

	No Load	Stall	Max Eff	Max Power
Speed (Rpm)	18800		15100	9400
Current (A)	8.587	142.674	35.001	75.63
Torque (mNm)		1468.7	289.33	734.35
Efficiency (%)			67.96	
Power			456.663	721.487



This four pole motor provides power and torque levels that enables the motor to meet the demanding requirements of saw applications

## Drawing:

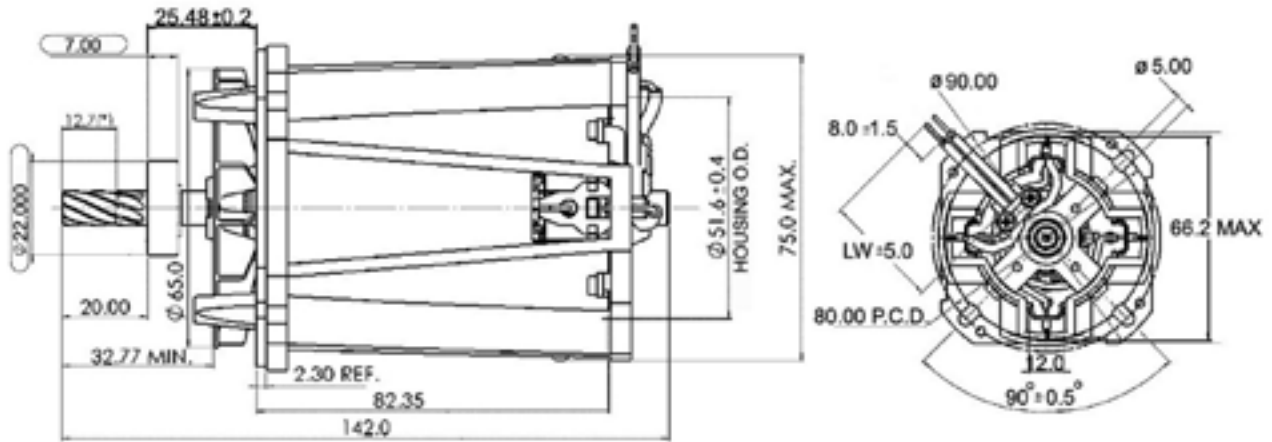

Unit in mm

## Performance Data:

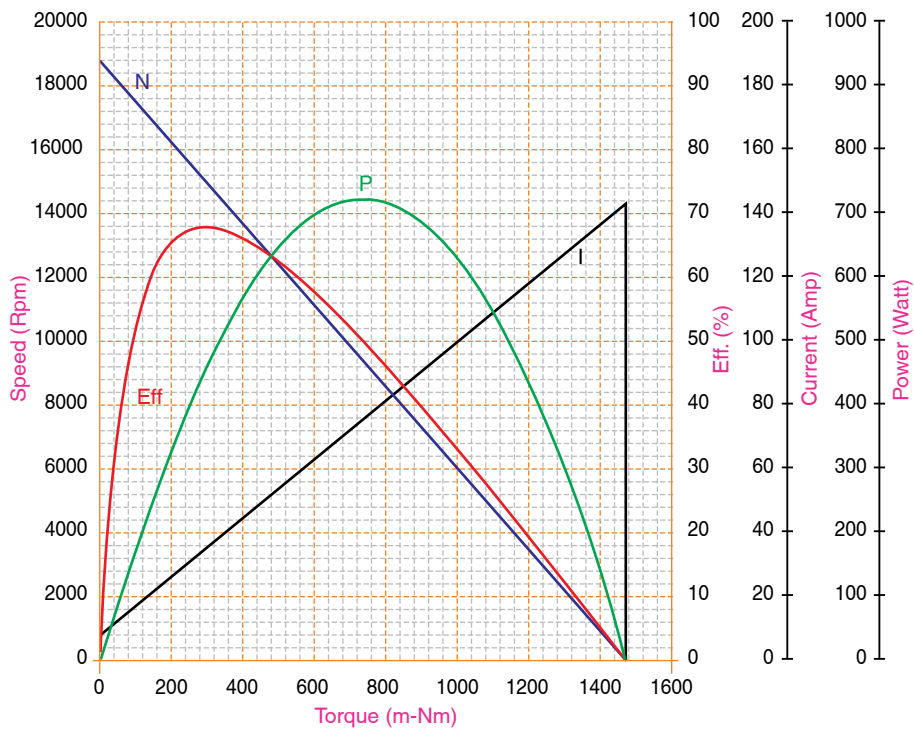

## Market

Power & Garden

## Application:

Drill

## Motor Characteristics:

Diameter	: 58 mm
Length	: 72 mm
Shaft Diameter	: 8 mm
Weight	: 734 g
Nominal Voltage	: 24 V
Torque Constant	: 11.048 m-Nm/A
Dynamic Resistance	: 0.132 Ohms
Motor Regulations	: 10.871 Rpm/m-Nm
Pole Number	: 12

## Standard Data:

Operation Temperature	: -10 — 50°C
Storage Temperature	: -20 — 100°C
Mounting	: Any position
Electrical Connection	: Terminal
Power Consumption	: 766.6 W
Power Output	: 550.0 W
Running Torque	: 291.0
Direction of Rotation	: CCW
Standard	: RoHS

## Electrical Performance:

	No Load	Stall	Max Eff	Max Power
Speed (Rpm)	21200		18000	10600
Current (A)	5.5	182.168	31.94	93.884
Torque (mNm)		1950.165	290.99	975.32
Efficiency (%)			71.75	
Power			549.994	1083.329



Having a long life and durability, this motor offers great performance for the cordless professional power tool applications

## Drawing:

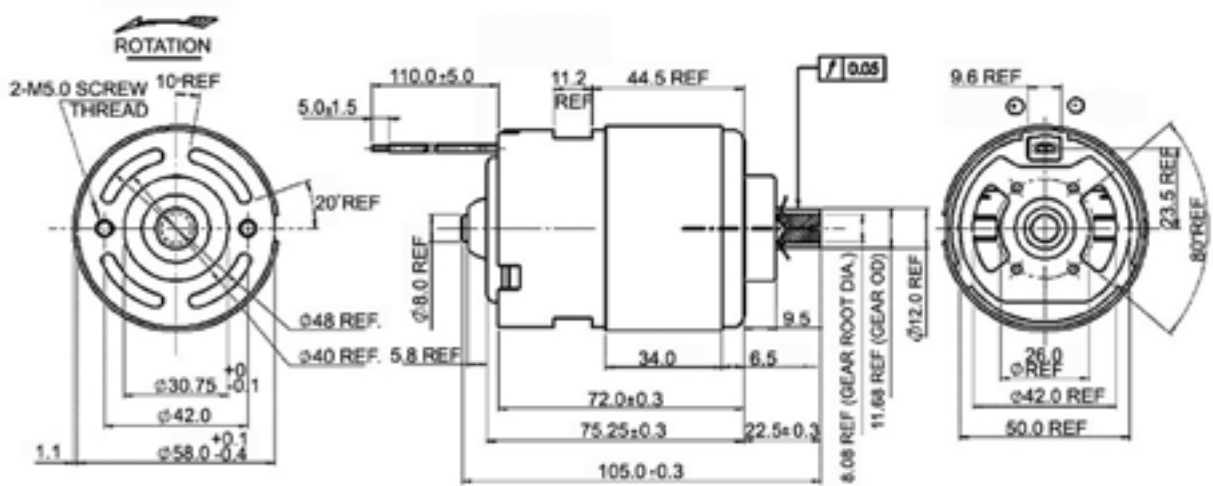

Unit in mm

## Performance Data:

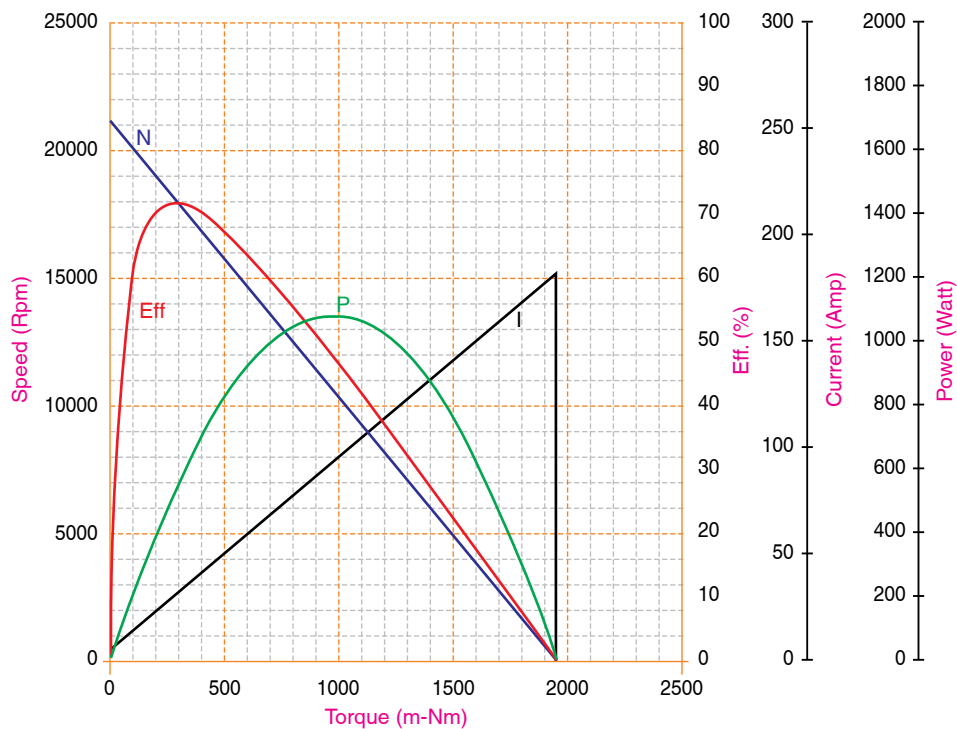

## Market

Personal Care

## Application:

Hair Curler

## Motor Characteristics:

Diameter	: 24.2 mm
Length	: 36 mm
Flat	: 18.3 mm
Shaft Diameter	: 2 mm
Weight	: 55 g
Nominal Voltage	: 24 V
Torque Constant	: 8.096 m-Nm/A
Dynamic Resistance	: 2.381 Ohms
Motor Regulations	: 340.921 Rpm/m-Nm
Pole Number	: 3



Popular motor with high power yet slim size

## Standard Data:

Operation Temperature	: -10 — 50°C
Storage Temperature	: -20 — 100°C
Mounting	: Any position
Electrical Connection	: Terminal
Winding Temperature (Tmax)	: 180 °C
Direction of Rotation	: CCW
Standards	: RoHS
Remarks	: Varistor

## Electrical Performance:

	No Load	Stall	Max Eff	Max Power
Speed (Rpm)	27000		23269	13539
Current (A)	0.27	10.08	1.65	5.18
Torque (mNm)		79.42	11.17	39.71
Efficiency (%)			68.79	
Power (W)			27.22	56.30



## Drawing:

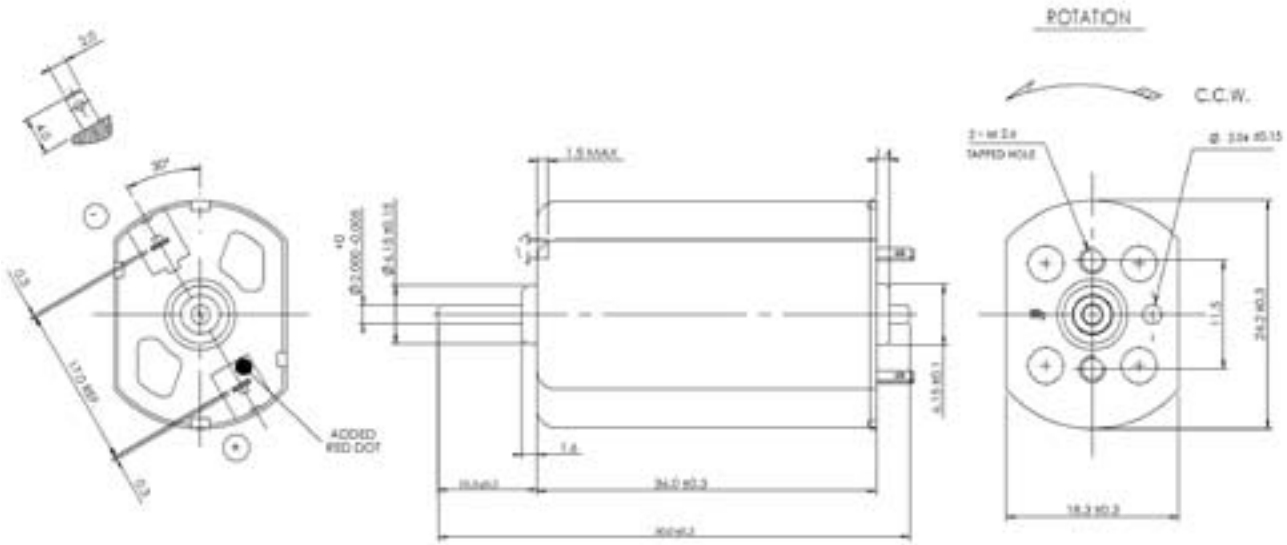

Unit in mm

## Performance Data:

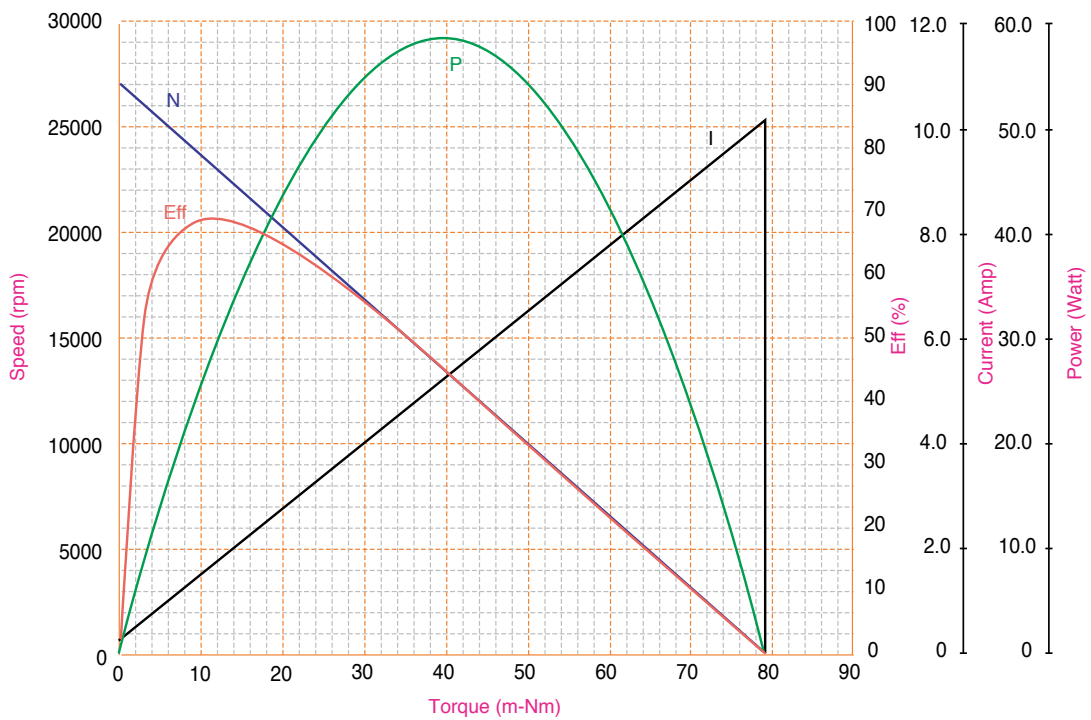

## Market

Leisure & Fitness

## Application:

All Terrain Ve-

## Motor Characteristics:

Diameter : 79 mm  
Length : 136 mm  
Shaft Diameter : 13 mm  
Weight : 1736 g  
Nominal Voltage : 12 V  
Pole Number : 4  
Rotar Stalling : 4.3 N.M

## Standard Data:

Operation Temperature : -10 — 50°C  
Storage Temperature : -20 — 100°C  
Mounting : Any position  
Electrical Connection : Terminal  
Power Output : 300 W  
Running Torque : 70.6 cNm  
Direction & Rotation : CCW

## Electrical Performance:

	No Load	Stall
Speed (Rpm)	5200	
Current (A)	15.00	260.00
Torque (mNm)		4300



This starter has an output shaft with two flats, radial electrical terminals and a customized motor to meet customer's winch performance requirements.

## Drawing:

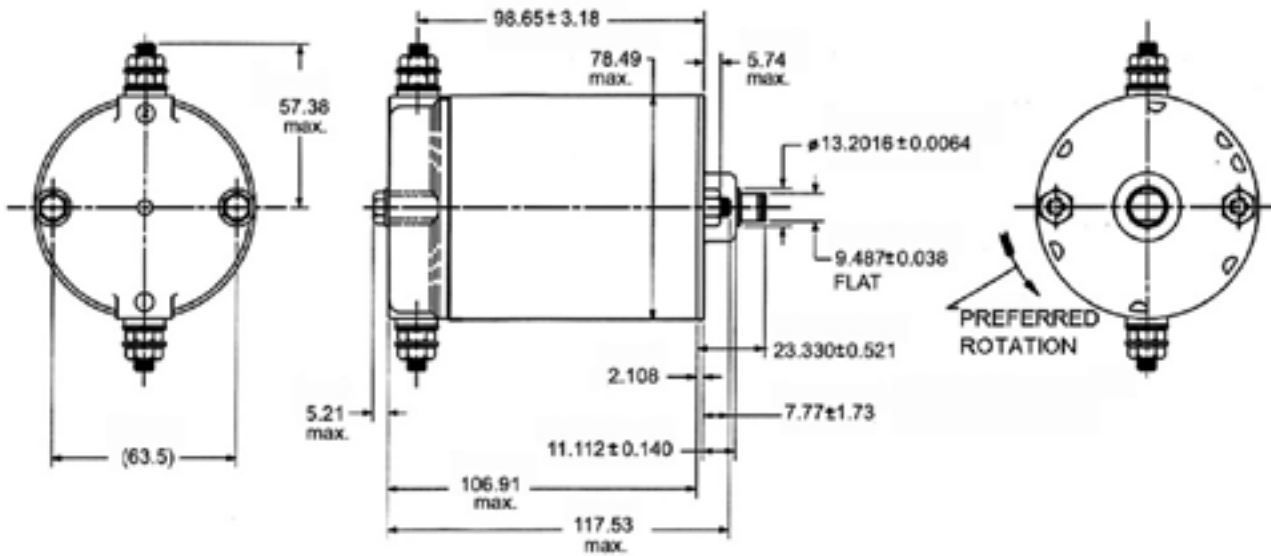

Unit in mm

## Performance Data:

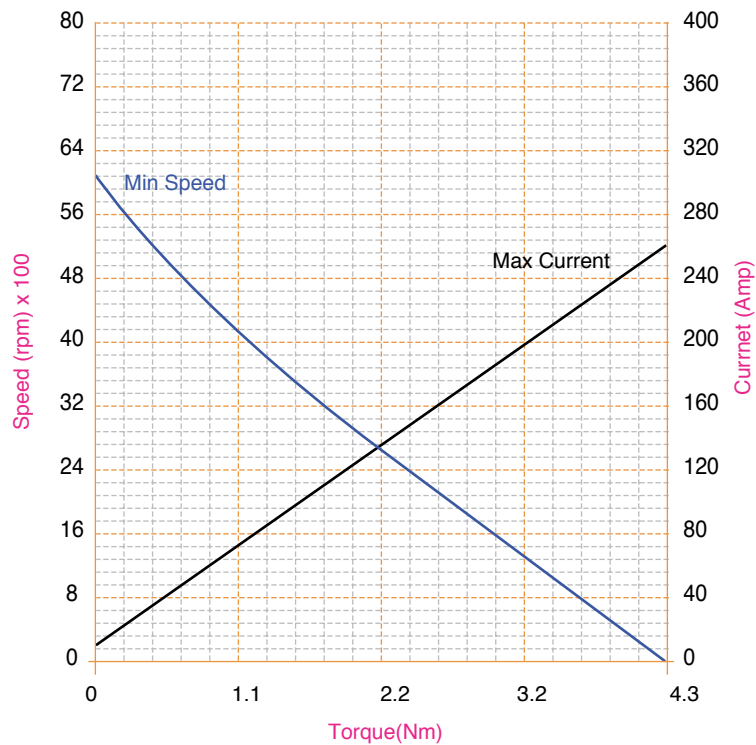

## Market

Leisure & Fitness

## Application:

Outboard Marine



This gear reduced, inertia drive electric starter has a custom motor mounting and a customized motor to meet customer's starting requirements with a 10 tooth pinion

## Motor Characteristics:

Diameter : 79 mm  
 Length : 266 mm  
 Weight : 3630 g  
 Nominal Voltage : 12 V  
 Pole Number : 4  
 Rotar Stalling : 6.8 N.M

## Standard Data:

Operation Temperature : -10 — 50°C  
 Storage Temperature : -20 — 100°C  
 Mounting : Any position  
 Electrical Connection : Terminal  
 Power Output : 740 W  
 Running Torque : 141.2 cNm  
 Direction of Rotation : CCW

## Electrical Performance:

	No Load	Stall
Speed (Rpm)	7800	
Current (A)	50.00	580.00
Torque (mNm)		6800

Drawing:

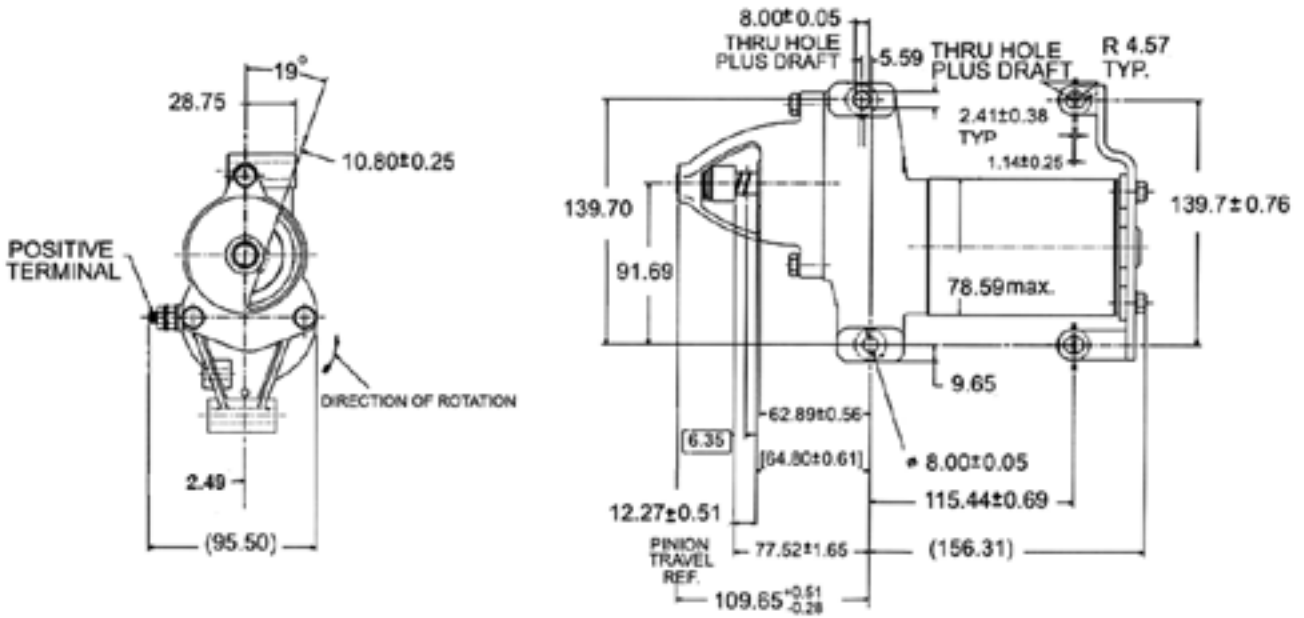

Unit in mm

Performance Data:

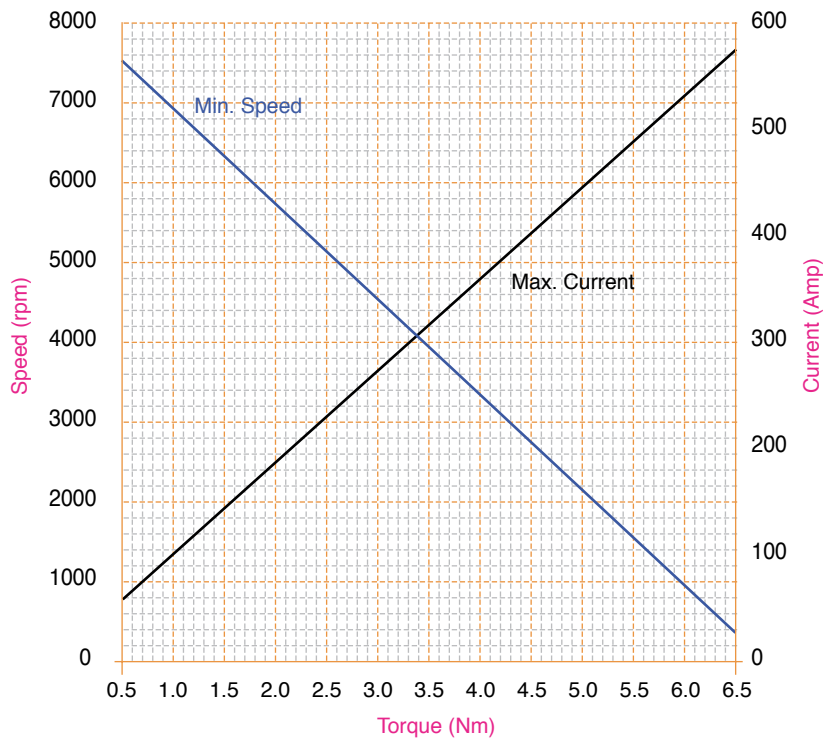

## Market

Leisure & Fitness

## Application:

Jet Skis (Personal Watercraft),  
All Terrain Vehicles

## Motor Characteristics:

Diameter : 79 mm  
Length : 210 mm  
Shaft Diameter : 9 mm  
Weight : 2347 g  
Nominal Voltage : 12 V  
Pole Number : 4  
Rotar Stalling : 4.8 N.M

## Standard Data:

Operation Temperature : -10 — 50°C  
Storage Temperature : -20 — 100°C  
Mounting : Any position  
Electrical Connection : Terminal  
Power Output : 560 W  
Running Torque : 141.2 cNm  
Direction of Rotation : CCW

## Electrical Performance:

	No Load	Stall
Speed (Rpm)	8500	
Current (A)	25.00	330.00
Torque (mNm)		4800



This starter has a custom motor mounting, output shaft with two flats and a customized motor to meet customer's starting requirements for one and three cylinder engines

## Drawing:

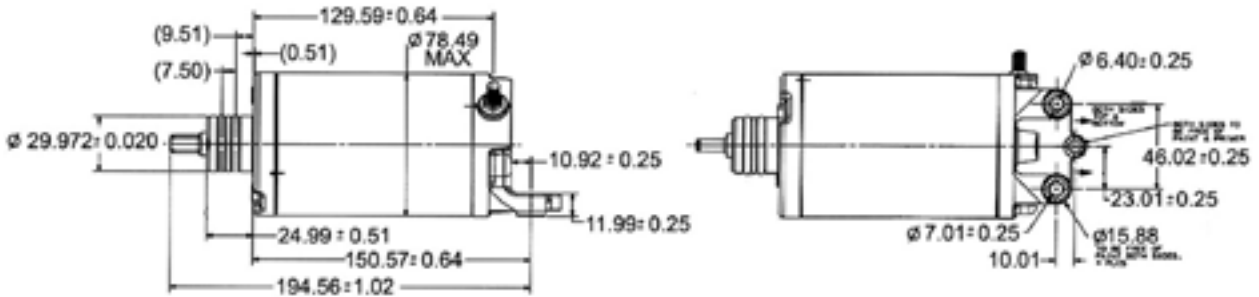

Unit in mm

## Performance Data:

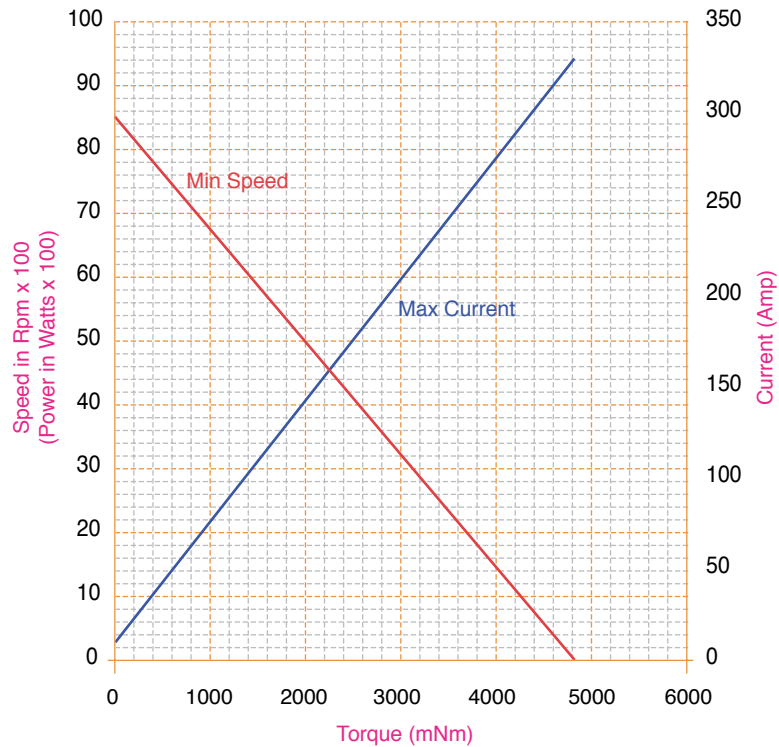

## Market

Leisure & Fitness

## Application:

Snowmobiles



This inertia drive starter with custom motor mounting and a customized motor meets customer's cold starting requirements at -40°C with a 9 tooth pinion

## Motor Characteristics:

Diameter	: 79 mm
Length	: 210 mm Max.
Weight	: 288 g
Nominal Voltage	: 12 V
Pole Number	: 4
Rotar Stalling	: 4.8 N.M

## Standard Data:

Operation Temperature	: -10 — 50°C
Storage Temperature	: -20 — 100°C
Mounting	: Any position
Electrical Connection	: Terminal
Power Output	: 870 W
Running Torque	: 211.8 cNm
Direction of Rotation	: CW

## Electrical Performance:

	No Load	Stall
Speed (Rpm)	7500	
Current (A)	20.00	330.00
Torque (mNm)		4800



## Drawing:

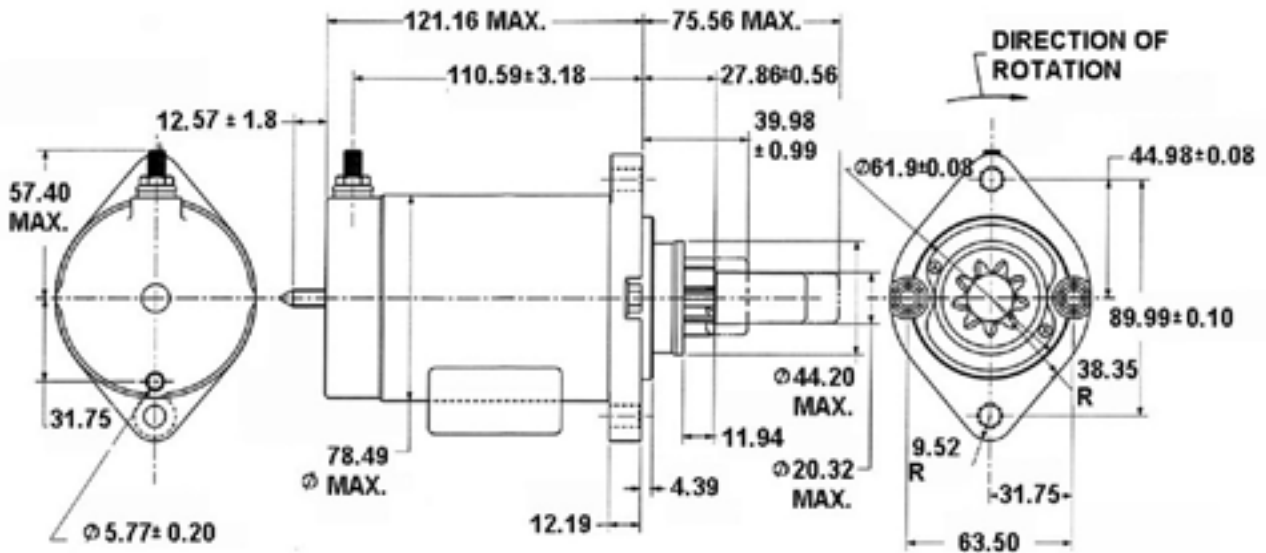

Unit in mm

## Performance Data:

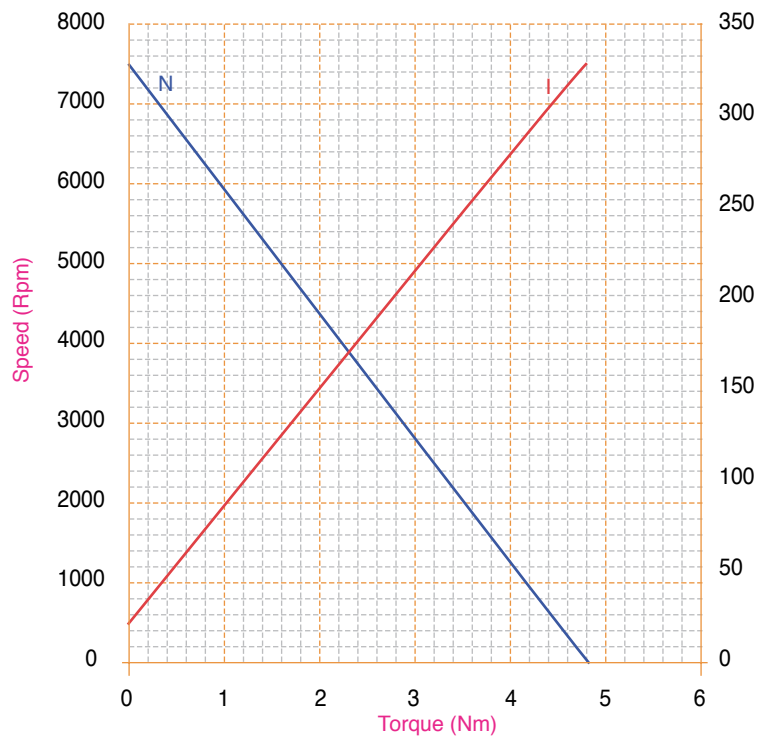

## Market

Leisure & Fitness

## Application:

Lawn Mower



This inertia drive starter with custom motor mounting is used for twin cylinder engines, 13 tooth pinion

## Motor Characteristics:

Diameter : 79 mm  
Length : 185 mm  
Weight : 2300 g  
Nominal Voltage : 12 V  
Pole Number : 4  
Rotar Satlling : 4.8 N.M

## Standard Data:

Operation Temperature : -10 — 50°C  
Storage Temperature : -20 — 100°C  
Mounting : Any position  
Electrical Connection : Terminal  
Power Output : 875 w  
Running Torque : 211.2 cNm  
Direction & Rotation : CCW

## Electrical Performance:

	No Load	Stall
Speed (Rpm)	9000	
Current (A)	25.000	370.000
Torque (mNm)		4800

## Drawing:

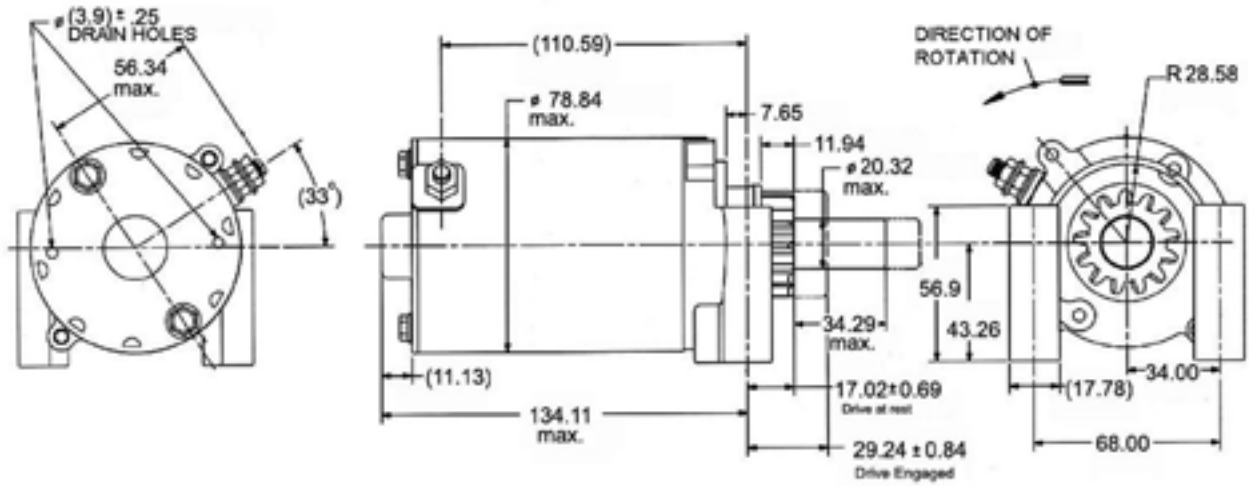

Unit in mm

## Performance Data:

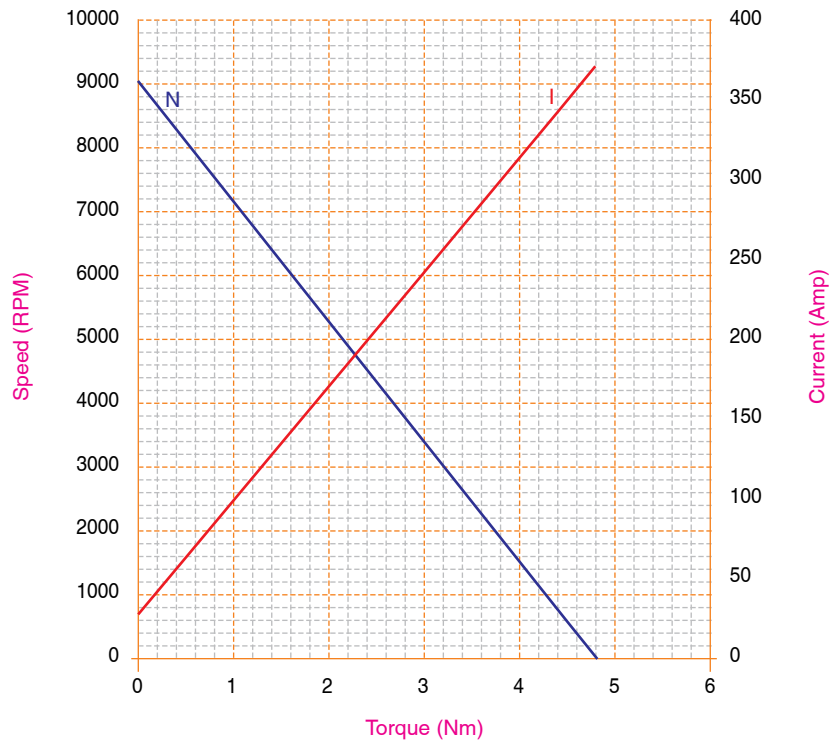

## Market

Home Appliances

## Application:

Hand Vacu-

## Motor Characteristics:

Diameter	: 35.8 mm
Length	: 57 mm
Shaft Diameter	: 3.17 mm
Weight	: 202 g
Nominal Voltage	: 14.4 V
Torque Constant	: 5.242 m-Nm/A
Dynamic Resistance	: 0.218 Ohms
Motor Regulations	: 77.354 Rpm/m-Nm
Pole Number	: 3

## Standard Data:

Operation Temperature	: -10 — 50°C
Storage Temperature	: -20 — 100°C
Mounting	: Any position
Electrical Connection	: Terminal
Power Output	: 123.89 W
Running Torque	: 54.95 mNm
Direction of Rotation	: CCW
Standard	: RoHS

## Electrical Performance:

	No Load	Stall	Max Eff	Max Power
Speed (Rpm)	25800		21500	12900
Current (A)	2.58	66.14	13.06	34.36
Torque (mNm)		333.17	54.95	166.58
Efficiency (%)			65.86	
Output Power (W)			123.89	224.88



This #600 series motor is small, high speed and efficient, and has a long life. It has the leading position for use in portable hand vac applications

## Drawing:

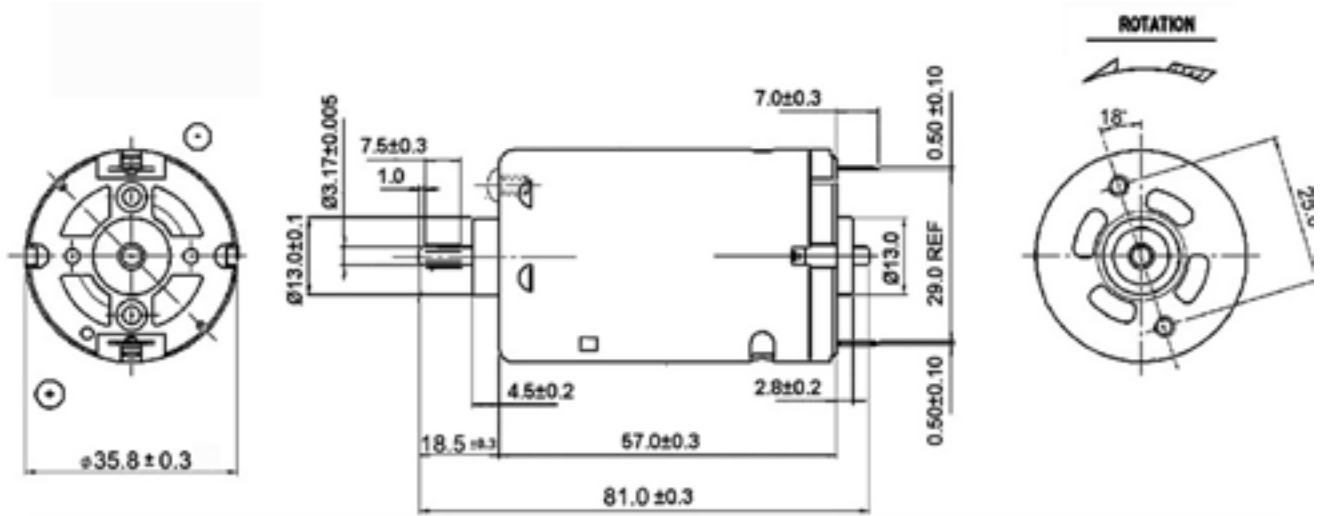

Unit in mm

## Performance Data:

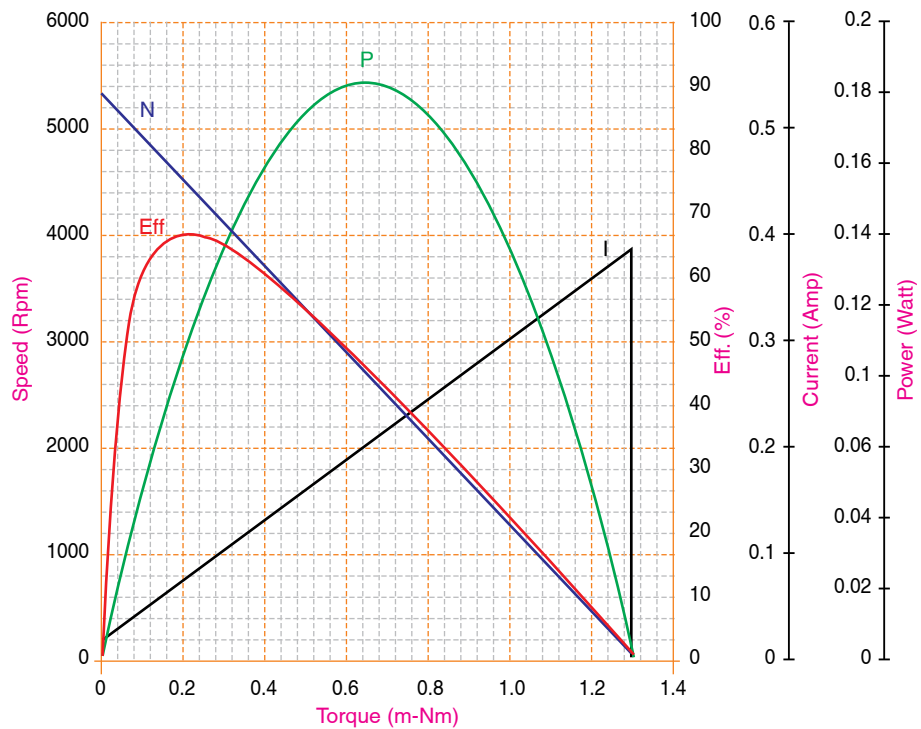

## Market

Consumer Electronics

## Application:

Camcorder, Car CD



This compact size motor is designed to have good starting voltage and cogging to fit into both sled and loading applications.

## Motor Characteristics:

Diameter	: 15.5 mm
Length	: 18.6 mm
Flat	: 12 mm
Shaft Diameter	: 1.505 mm
Nominal Voltage	: 5 V
Weight	: 10.4 g
Torque Constant	: 3.267 m-Nm/A
Dynamic Resistance	: 8.16 Ohms
Motor Regulations	: 5612.245 Rpm/m-Nm
Pole Number	: 3

## Standard Data:

Operating Temperature	: -10 — 50°C
Storage Temperature	: -20 — 100°C
Mounting	: Any position
Electrical Connection	: Terminal
Standards	: RoHS

## Electrical Performance:

	No Load	Stall	Max Eff	Max Power
Speed (Rpm)	10500		8363	5250
Current (A)	0.04	0.613	0.157	0.326
Torque (mNm)		1.871	0.381	0.649
Efficiency (%)			55.43	
Power (W)			0.334	0.514

## Drawing:

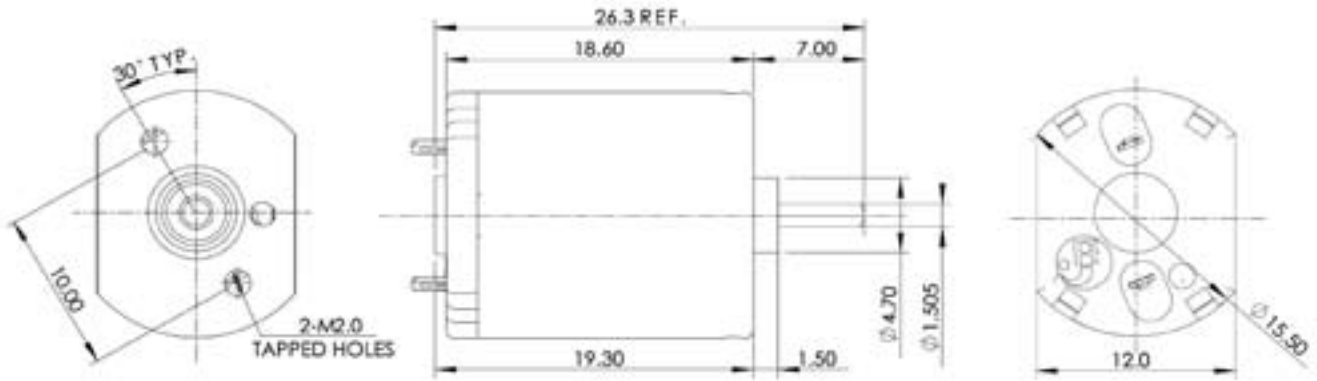

Unit in mm

## Performance Data:

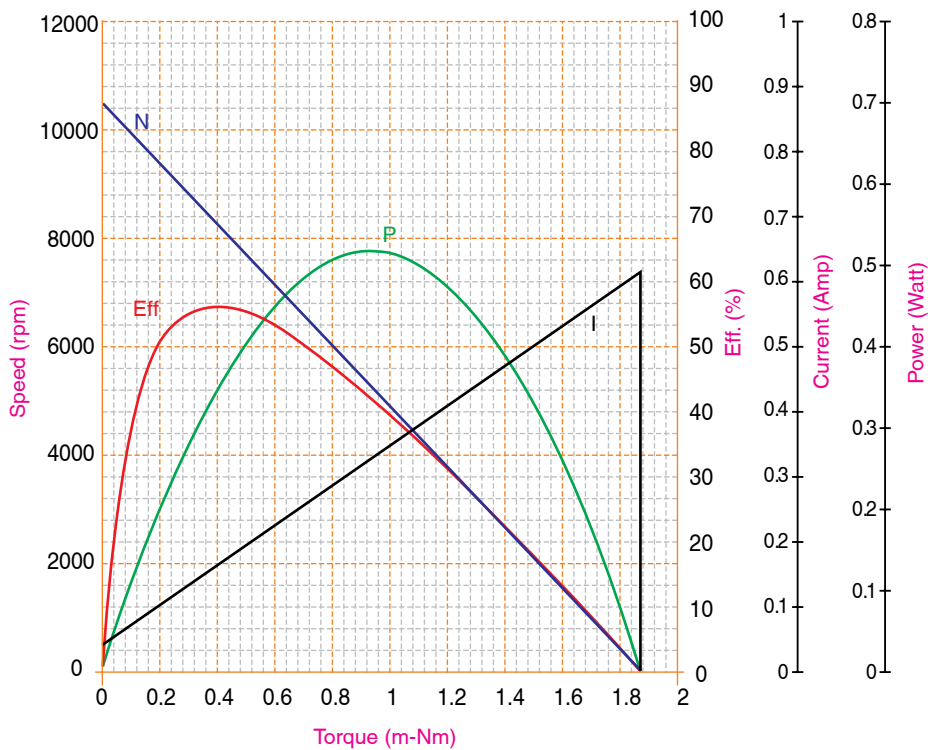

## Market

Consumer Electronics

## Application:

DVD ROM, MD Player



The NF003SG is compact in size with good cogging, making it ideal for slim sled application.

## Motor Characteristics:

Diameter	: 15.5 mm
Length	: 18.6 mm
Flat	: 12 mm
Shaft Diameter	: 1.505 mm
Weight	: 10.4 g
Nominal Voltage	: 2 V
Torque Constant	: 3.521 m-Nm/A
Dynamic Resistance	: 5.231 Ohms
Motor Regulations	: 4086.446 Rpm/m-Nm
Pole Number	: 3

## Standard Data:

Operating Temperature	: -10 — 50°C
Storage Temperature	: -20 — 100°C
Mounting	: Any position
Electrical Connection	: Terminal
Standards	: RoHS

## Electrical Performance:

	No Load	Stall	Max Eff	Max Power
Speed (Rpm)	5300		4451	2650
Current (A)	0.014	0.382	0.073	0.2
Torque (mNm)		1.297	0.208	0.648
Efficiency (%)			65.35	
Power (W)			0.097	0.18



## Drawing:

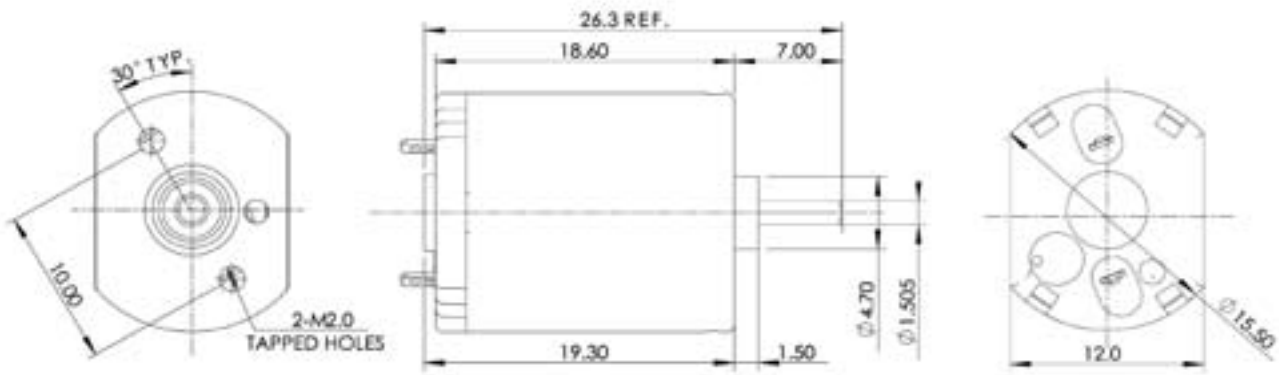

Unit in mm

## Performance Data:

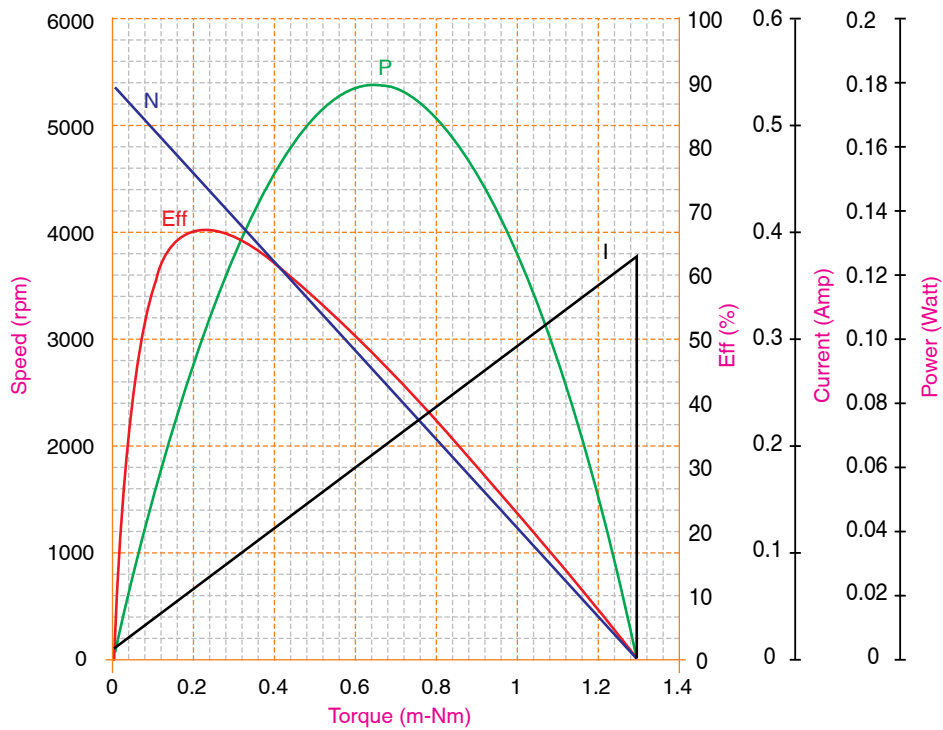

## Market

Consumer Electronics

## Application:

Game Controller



## Motor Characteristics:

Diameter	: 15.5 mm
Length	: 18.6 mm
Flat	: 12 mm
Shaft Diameter	: 1.505 mm
Weight	: 13.0 g
Nominal Voltage	: 5 V
Torque Constant	: 7.334 m-Nm/A
Dynamic Resistance	: 38.462 Ohms
Motor Regulations	: 6363.347 Rpm/m-Nm
Pole Number	: 3

This typical compact and high speed motor has an eccentric/ balancer to produce the feel of high spin vibration for game controllers. It is widely-used in popular game player controllers.

## Standard Data:

Operating Temperature	: -10 — 50°C
Storage Temperature	: -20 — 100°C
Mounting	: Any position
Electrical Connection	: Terminal
Standards	: RoHS

## Electrical Performance:

	No Load	Stall	Max Eff	Max Power
Speed (Rpm)	5600		4384	2800
Current (A)	0.010	0.130	0.036	0.070
Torque (mNm)		0.880	0.191	0.044
Efficiency (%)			52.22	
Power (W)			0.088	0.129

## Drawing:

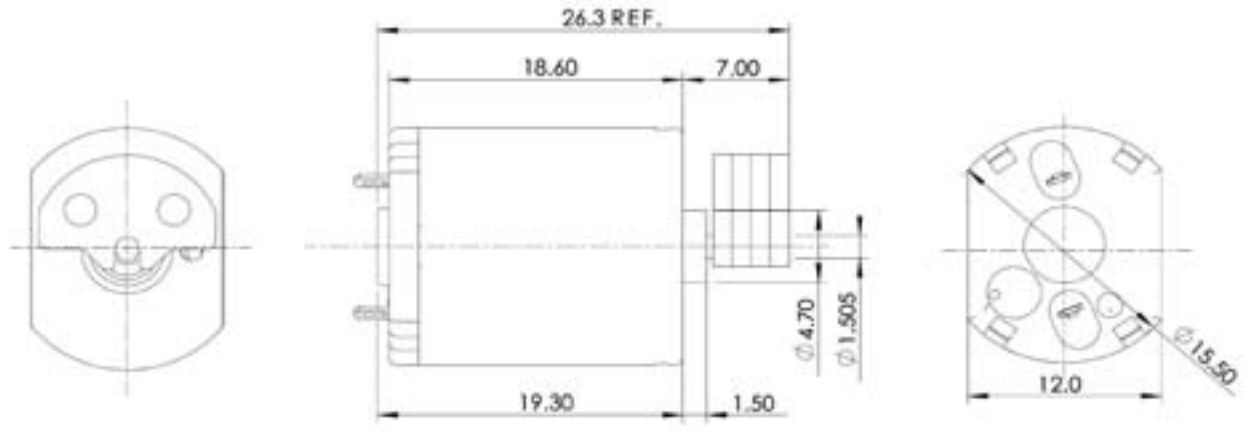

Unit in mm

## Performance Data:

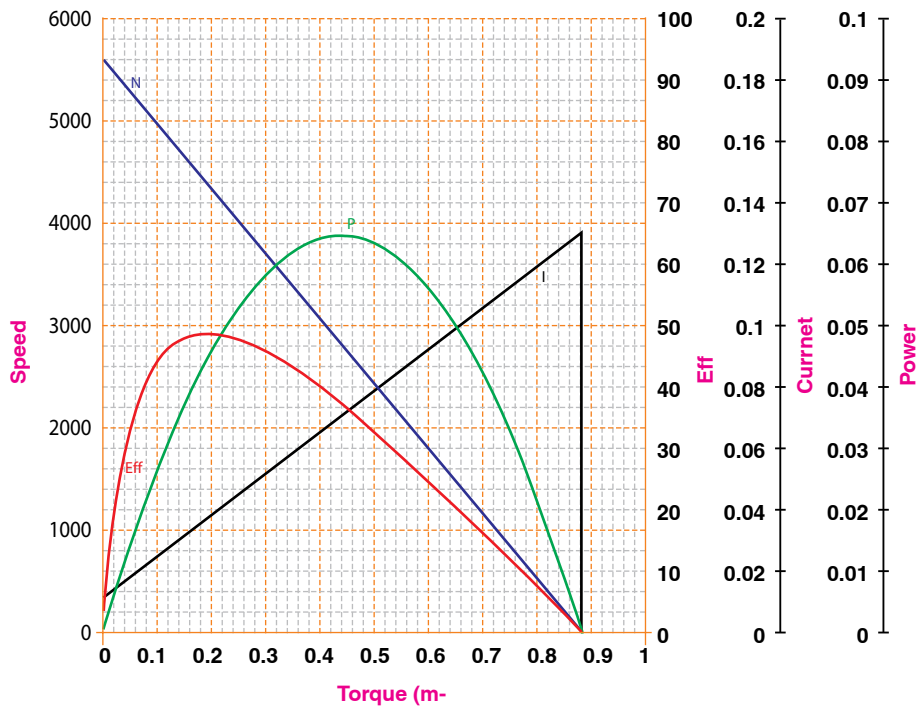

## Market

Personal Care

## Application:

Hair Curler

## Motor Characteristics:

Diameter	: 20.4 mm
Length	: 32.1 mm
Flat	: 15.4 mm
Shaft Diameter	: 2 mm
Weight	: 28.5 g
Nominal Voltage	: 13 V
Torque Constant	: 5.197 m-Nm/A
Dynamic Resistance	: 5.603 Ohms
Motor Regulations	: 2091.803 Rpm/m-Nm
Pole Number	: 3



Specially designed motor for mid power hair curler

## Standard Data:

Operation Temperature	: -10 — 50°C
Storage Temperature	: -20 — 100°C
Mounting	: Any position
Electrical Connection	: Terminal
Winding Temperature (Tmax)	: 180 °C
Direction of Rotation	: CCW
Standards	: RoHS
Remarks	: Varistor

## Electrical Performance:

	No Load	Stall	Max Eff	Max Power
Speed (Rpm)	22940		17635	11470
Current (A)	0.21	2.32	0.70	1.27
Torque (mNm)		10.97	2.54	5.48
Efficiency (%)			51.61	
Power (W)			4.68	6.59



## Market

Business Machines

## Application:

Scanner



## Motor Characteristics:

Diameter	: 20.4 mm
Length	: 25 mm
Flat	: 15.4 mm
Shaft Diameter	: 2 mm
Weight	: 21.8 g
Nominal Voltage	: 18 V
Torque Constant	: 12.591 m-Nm/A
Dynamic Resistance	: 31.942 Ohms
Motor Regulations	: 1874.787 Rpm/m-Nm
Pole Number	: 3

Encoder system that is compact in size, with EMI suppression components, used for precision motion control in scanner. Encoder systems can be designed according to customer's requirement.

## Standard Data:

Operation Temperature	: -10 — 55°C
Storage Temperature	: -20 — 100°C
Mounting	: Any position
Electrical Connection	: Connector
Winding Temperature (Tmax)	: 130 °C
Direction of Rotation	: CW& CCW
Standards	: RoHS

## Electrical Performance:

	No Load	Stall	Max Eff	Max Power
Speed (Rpm)	12020		9172	6010
Current (A)	0.054	0.564	0.175	0.309
Torque (mNm)		6.411	1.519	3.206
Efficiency (%)			46.34	
Power (W)			1.46	2.018

## Drawing:

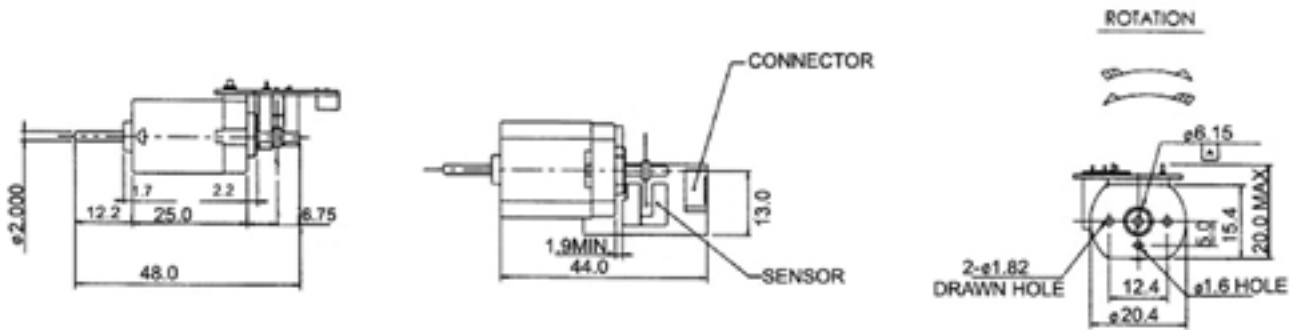

Unit in mm

## Performance Data:

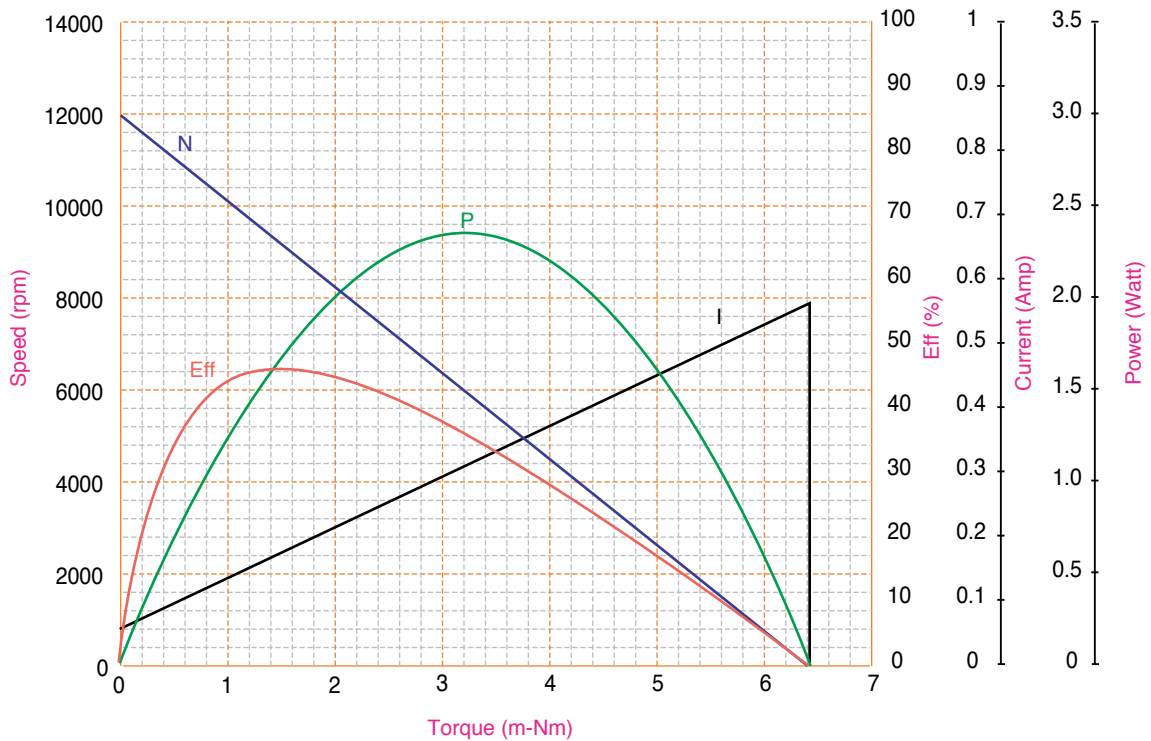

## Market

Personal Care

## Application:

Tooth-



Well-known motor with high power, low noise and high efficiency

## Motor Characteristics:

Diameter	: 20.4 mm
Length	: 32.1 mm
Flat	: 15.4 mm
Shaft Diameter	: 2 mm
Weight	: 28.7 g
Nominal Voltage	: 2.4 V
Torque Constant	: 3.478 m-Nm/A
Dynamic Resistance	: 1.007 Ohms
Motor Regulations	: 775.618 Rpm/m-Nm
Pole Number	: 3

## Standard Data:

Operation Temperature	: -10 — 50°C
Storage Temperature	: -20 — 100°C
Mounting	: Any position
Electrical Connection	: Terminal
Winding Temperature (Tmax)	: 130 °C
Direction of Rotation	: CCW
Standards	: RoHS

## Electrical Performance:

	No Load	Stall	Max Eff	Max Power
Speed (Rpm)	6212		5257	3105
Current (A)	0.08	2.38	0.43	1.23
Torque (mNm)		8.01	1.23	4.01
Efficiency (%)			65.30	
Power (W)			0.68	1.30



## Drawing:

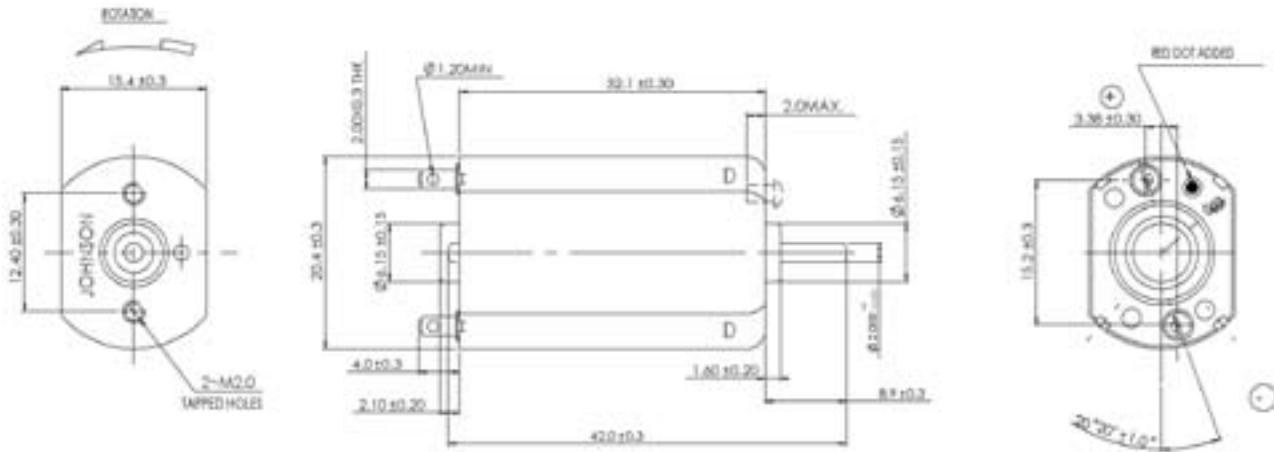

Unit in mm

## Performance Data:

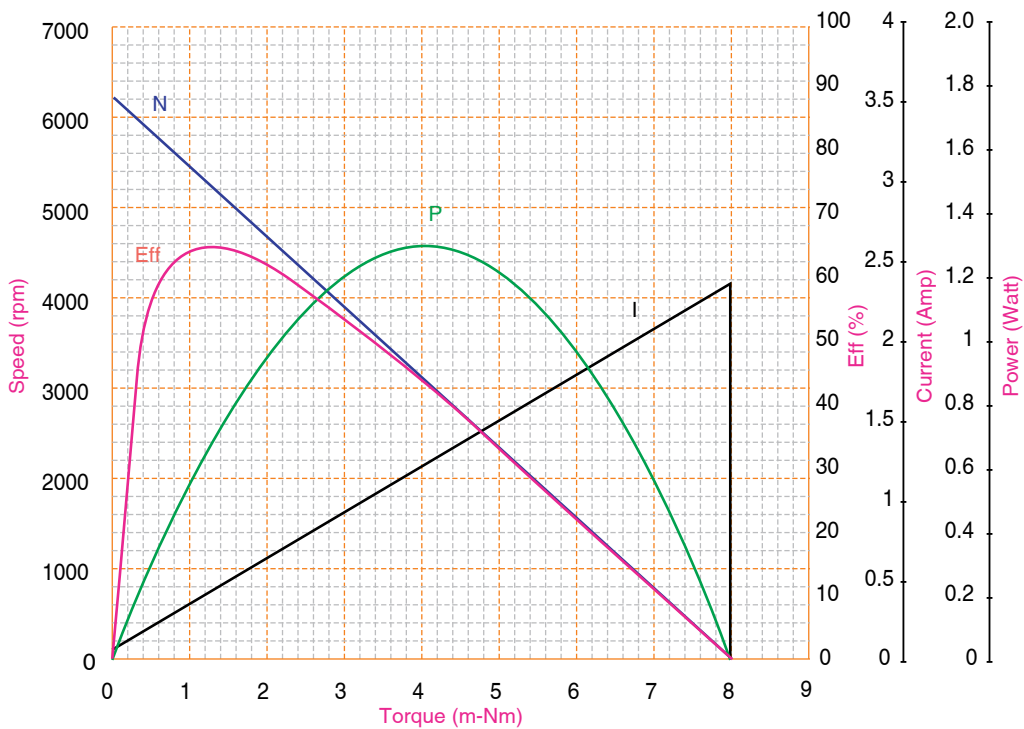

## Market

Personal Care

## Application:

Hair Trim-

## Motor Characteristics:

Diameter	: 24.2 mm
Length	: 30.5 mm
Flat	: 18.3 mm
Shaft Diameter	: 2 mm
Weight	: 45.8 g
Nominal Voltage	: 2.4 V
Torque Constant	: 3.026 m-Nm/A
Dynamic Resistance	: 0.321 Ohms
Motor Regulations	: 315.906 Rpm/m-Nm
Pole Number	: 3



The most widely-used motor for hair trimmer

## Standard Data:

Operation Temperature	: -10 — 50°C
Storage Temperature	: -20 — 100°C
Mounting	: Any position
Electrical Connection	: Terminal
Winding Temperature (Tmax)	: 130 °C
Direction of Rotation	: CCW
Standards	: RoHS

## Electrical Performance:

	No Load	Stall	Max Eff	Max Power
Speed (Rpm)	6967		6000	3484
Current (A)	0.19	7.48	1.20	4.02
Torque (mNm)		22.05	3.05	11.03
Efficiency (%)			66.53	
Power (W)			1.92	4.02

## Drawing:

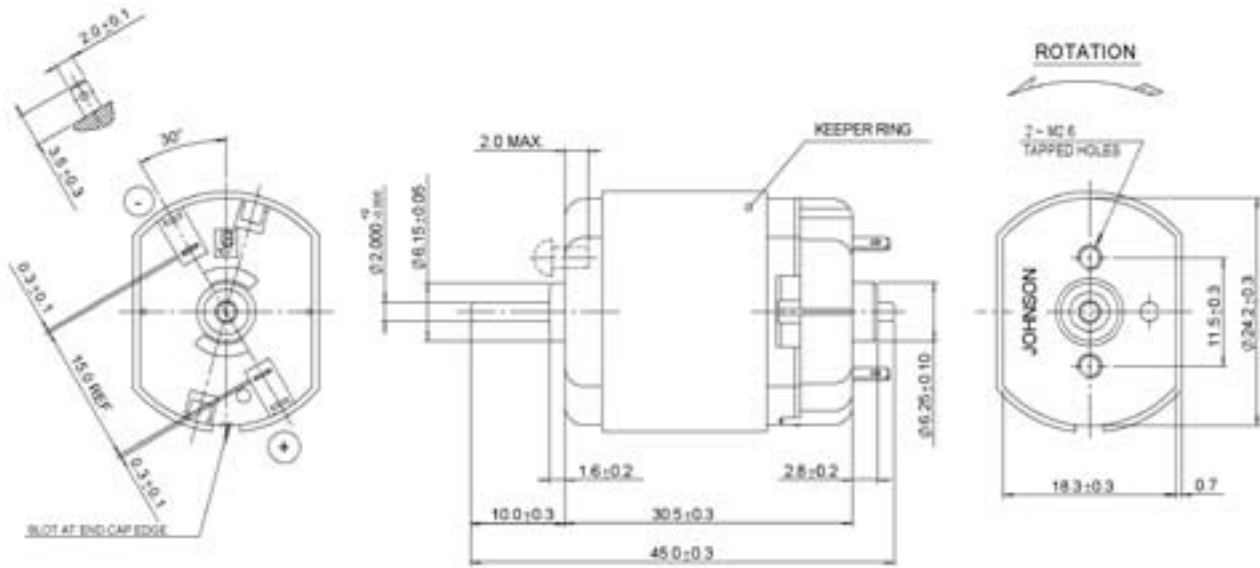

Unit in mm

## Performance Data:



## Market

Personal Care

## Application:

Hair Trim-

## Motor Characteristics:

Diameter	: 24.2 mm
Length	: 30.5 mm
Flat	: 18.3 mm
Shaft Diameter	: 2 mm
Weight	: 37.2 g
Nominal Voltage	: 1.2 V
Torque Constant	: 1.290 m-Nm/A
Dynamic Resistance	: 0.119 Ohms
Motor Regulations	: 625.649 Rpm/m-Nm
Pole Number	: 3



The most widely-used motor for hair trimmer

## Standard Data:

Operation Temperature	: -10 — 50°C
Storage Temperature	: -20 — 100°C
Mounting	: Any position
Electrical Connection	: Terminal
Winding Temperature (Tmax)	: 130 °C
Direction of Rotation	: CCW
Standards	: RoHS

## Electrical Performance:

	No Load	Stall	Max Eff	Max Power
Speed (Rpm)	7835		6539	3918
Current (A)	0.40	10.11	2.00	5.25
Torque (mNm)		12.51	2.07	6.26
Efficiency (%)			59.00	
Power (W)			1.42	2.57

## Drawing:

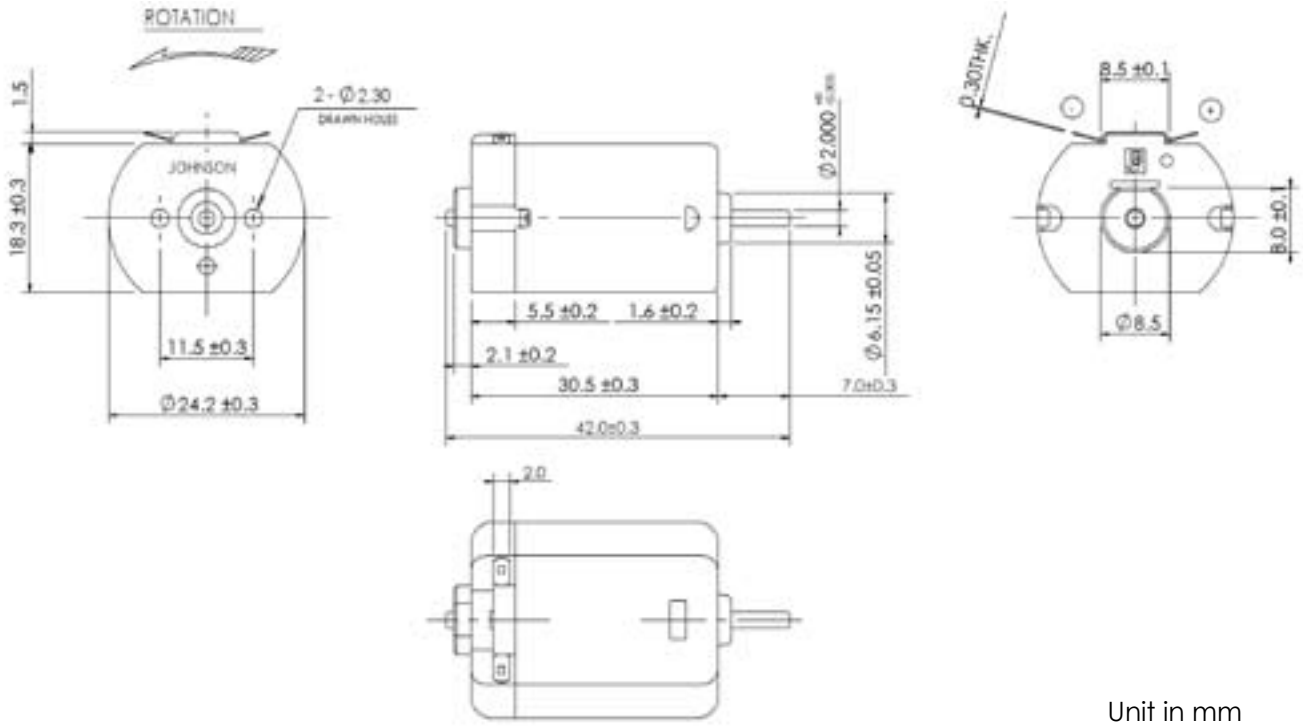

PMDC

## Performance Data:

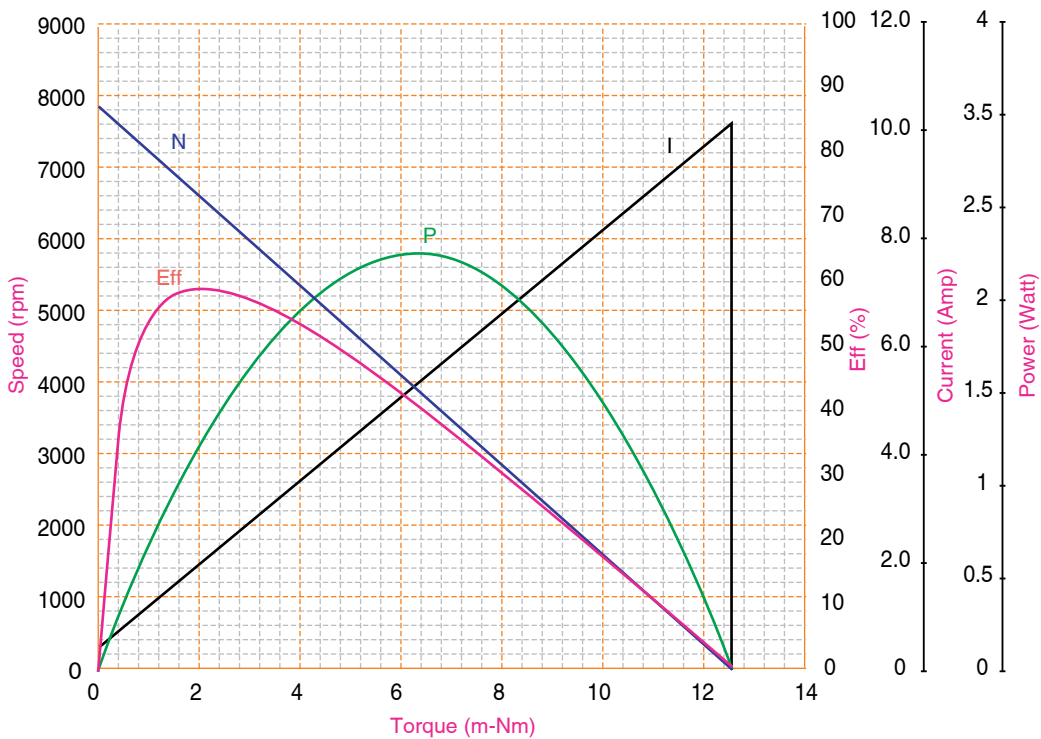

## Market

Consumer Electronics

## Application:

CD ROM, DVD Player, CD-R/

## Motor Characteristics:

Diameter	: 24.4 mm
Length	: 12.3 mm
Shaft Diameter	: 2 mm
Weight	: 20.4 g
Nominal Voltage	: 3.9 V
Torque Constant	: 7.603 m-Nm/A
Dynamic Resistance	: 11.096 Ohms
Motor Regulations	: 1814.059 Rpm/m-Nm
Pole Number	: 3



The motor has low cogging used for sled application in computer drive and DVD player.

## Standard Data:

Operating Temperature	: -10 — 50°C
Storage Temperature	: -20 — 100°C
Mounting	: Any position
Electrical Connection	: Leadwire
Standards	: RoHS

## Electrical Performance:

	No Load	Stall	Max Eff	Max Power
Speed (Rpm)	4600		3751	2300
Current (A)	0.018	0.352	0.080	0.185
Torque (mNm)		2.536	0.468	1.268
Efficiency (%)			59.86	
Power (W)			0.184	0.305

## Drawing:

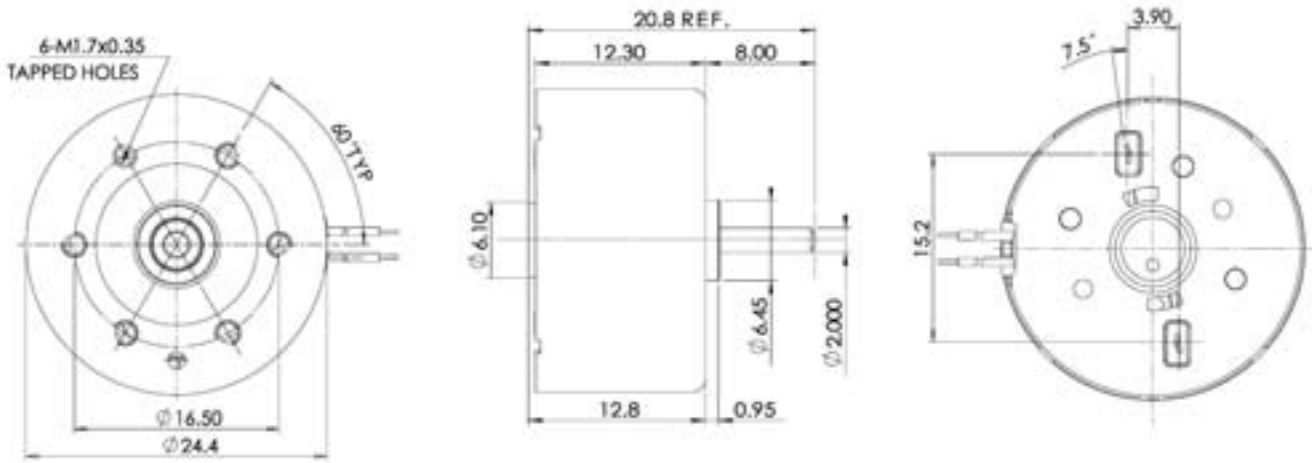

Unit in mm

## Performance Data:

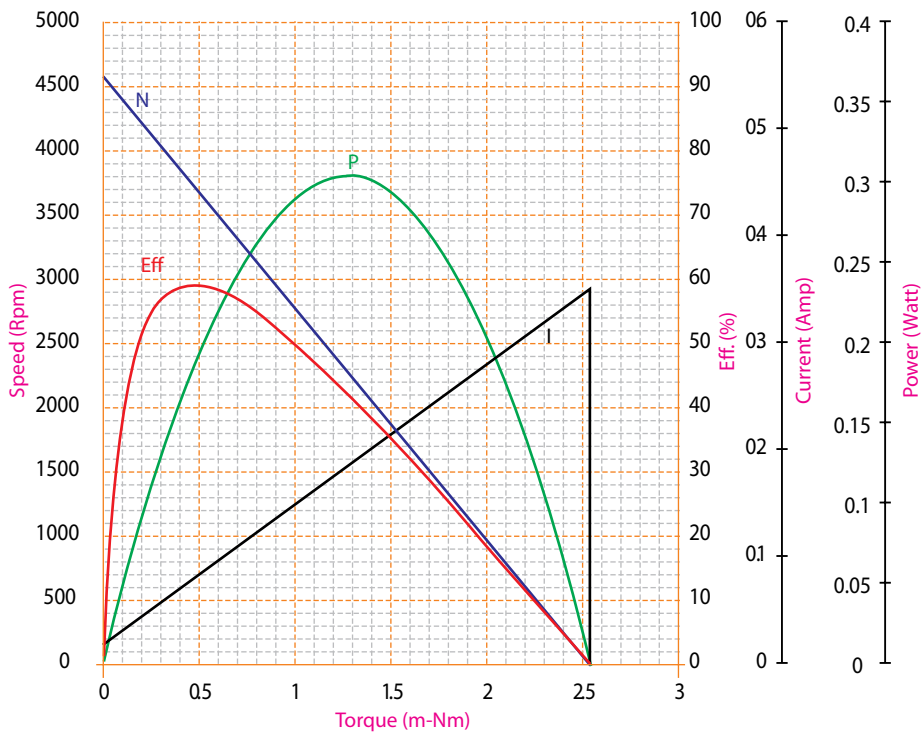

## Market

Consumer Electronics

## Application:

CD/DVD ROM, CD-R/RW, CD/VCD/DVD



With its compact size and long running life, this is a perfect motor for the loading application in computer and audio-visual drives.

## Motor Characteristics:

Diameter	: 24.4 mm
Length	: 12.3 mm
Shaft Diameter	: 2 mm
Weight	: 20.4 g
Nominal Voltage	: 2 V
Torque Constant	: 7.84 m-Nm/A
Dynamic Resistance	: 12.214 Ohms
Motor Regulations	: 2040.816 Rpm/m-Nm
Pole Number	: 3

## Standard Data:

Operating Temperature	: -10 — 50°C
Storage Temperature	: -20 — 100°C
Mounting	: Any position
Electrical Connection	: Terminal
Standards	: RoHS

## Electrical Performance:

	No Load	Stall	Max Eff	Max Power
Speed (Rpm)	2300		1704	1150
Current (A)	0.02	0.164	0.057	0.092
Torque (mNm)		1.127	0.292	0.564
Efficiency (%)			43.32	
Power (W)			0.052	0.068



Drawing:

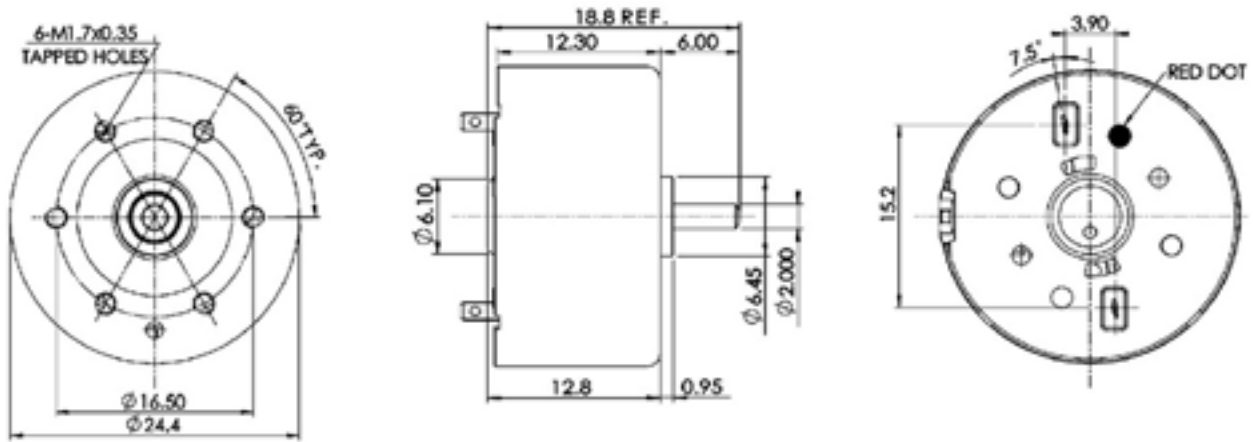

Unit in mm

Performance Data:

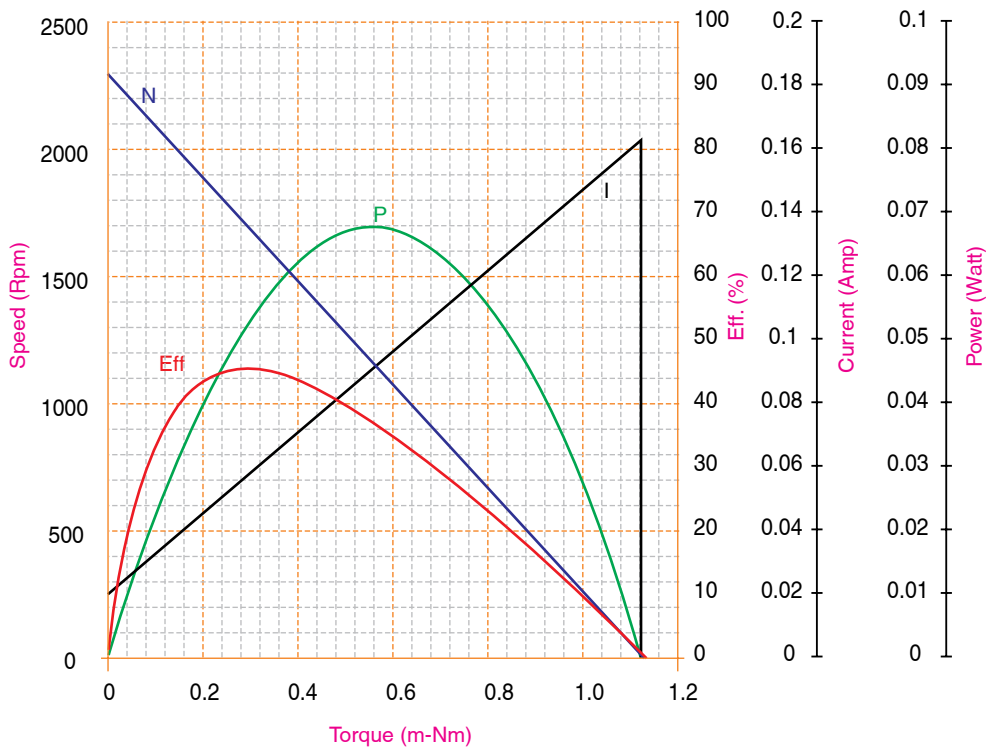

## Market

Consumer Electronics

## Application:

DVD Player

## Motor Characteristics:

Diameter	: 24.4 mm
Length	: 12.3 mm
Shaft Diameter	: 2 mm
Weight	: 20.4 g
Nominal Voltage	: 3 V
Torque Constant	: 7.84 m-Nm/A
Dynamic Resistance	: 21.739 Ohms
Motor Regulations	: 2039.217 Rpm/m-Nm
Pole Number	: 3



This typical compact spindle motor has low cogging and long running life and fits the market requirement to slim CD/VCD/DVD players

## Standard Data:

Operating Temperature	: -10 — 50°C
Storage Temperature	: -20 — 100°C
Mounting	: Any position
Electrical Connection	: Terminal
Standards	: RoHS

## Electrical Performance:

	No Load	Stall	Max Eff	Max Power
Speed (Rpm)	2550		2009	1275
Current (A)	0.010	0.138	0.037	0.074
Torque (mNm)		1.250	0.265	0.625
Efficiency (%)			53.41	
Power (W)			0.056	0.084

## Drawing:

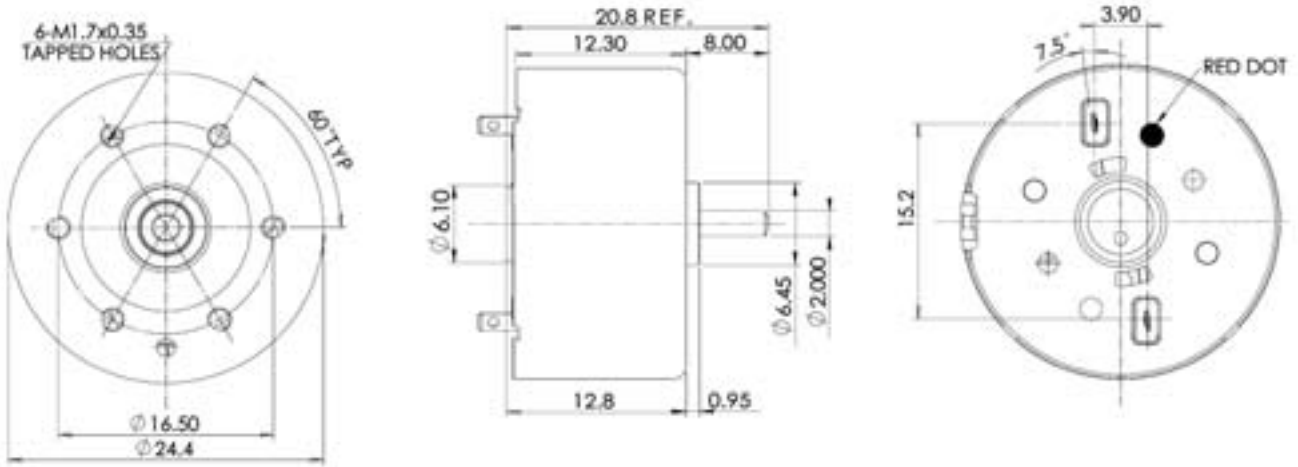

Unit in mm

## Performance Data:

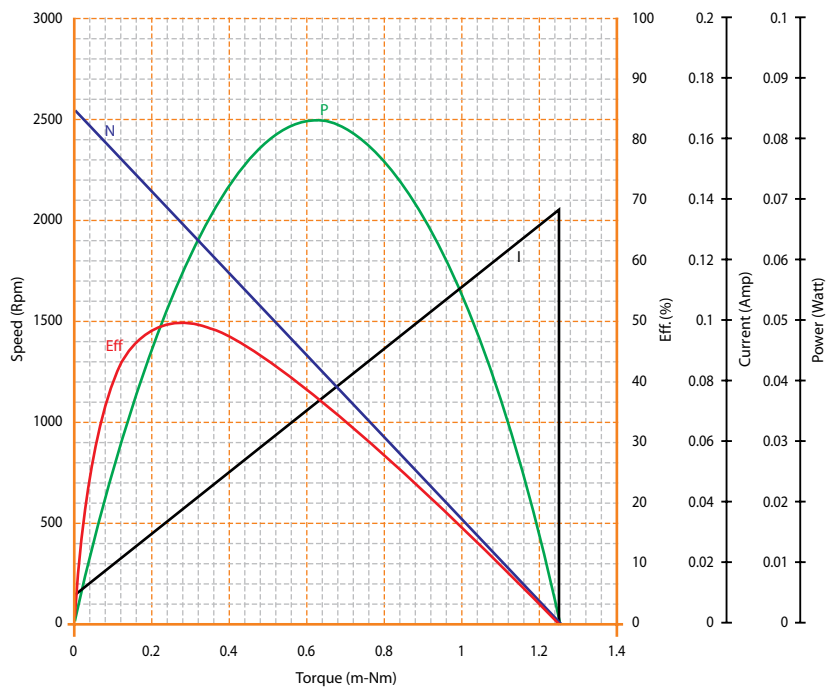

## Market

Consumer Electronics

## Application:

DVD ROM



This excellent low starting voltage and low cogging motor allows a smooth feeding/sled movement in computer and DVD applications

## Motor Characteristics:

Diameter	: 24.4 mm
Length	: 12.3 mm
Shaft Diameter	: 2 mm
Weight	: 20.4 g
Nominal Voltage	: 2 V
Torque Constant	: 8.253 m-Nm/A
Dynamic Resistance	: 14.983 Ohms
Motor Regulations	: 2295.918 Rpm/m-Nm
Pole Number	: 3

## Standard Data:

Operating Temperature	: -10 — 50°C
Storage Temperature	: -20 — 100°C
Mounting	: Any position
Electrical Connection	: Leadwire
Standards	: RoHS

## Electrical Performance:

	No Load	Stall	Max Eff	Max Power
Speed (Rpm)	2330		1762	1150
Current (A)	0.013	0.134	0.041	0.073
Torque (mNm)		1.002	0.234	0.501
Efficiency (%)			48.23	
Power (W)			0.043	0.06

## Drawing:

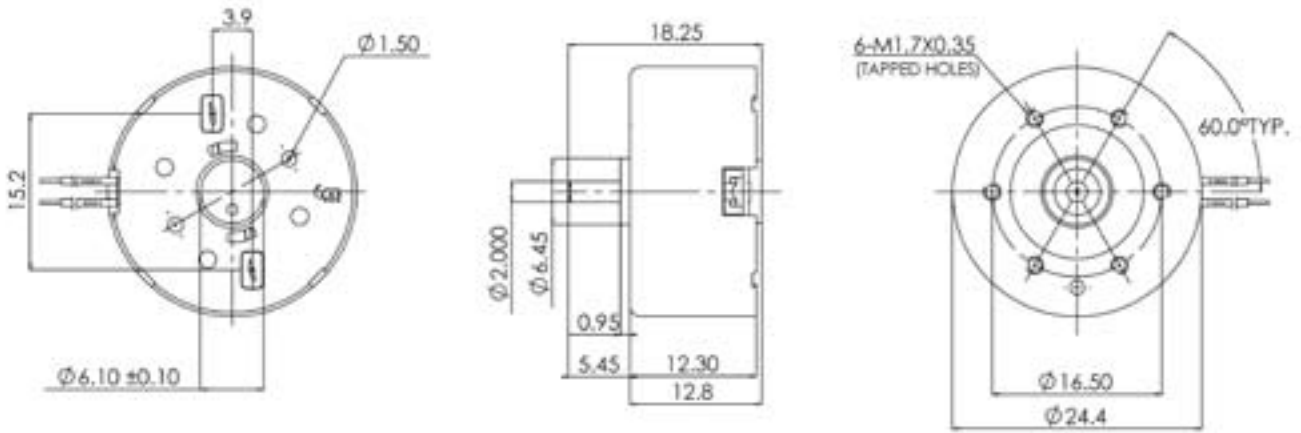

Unit in mm

## Performance Data:

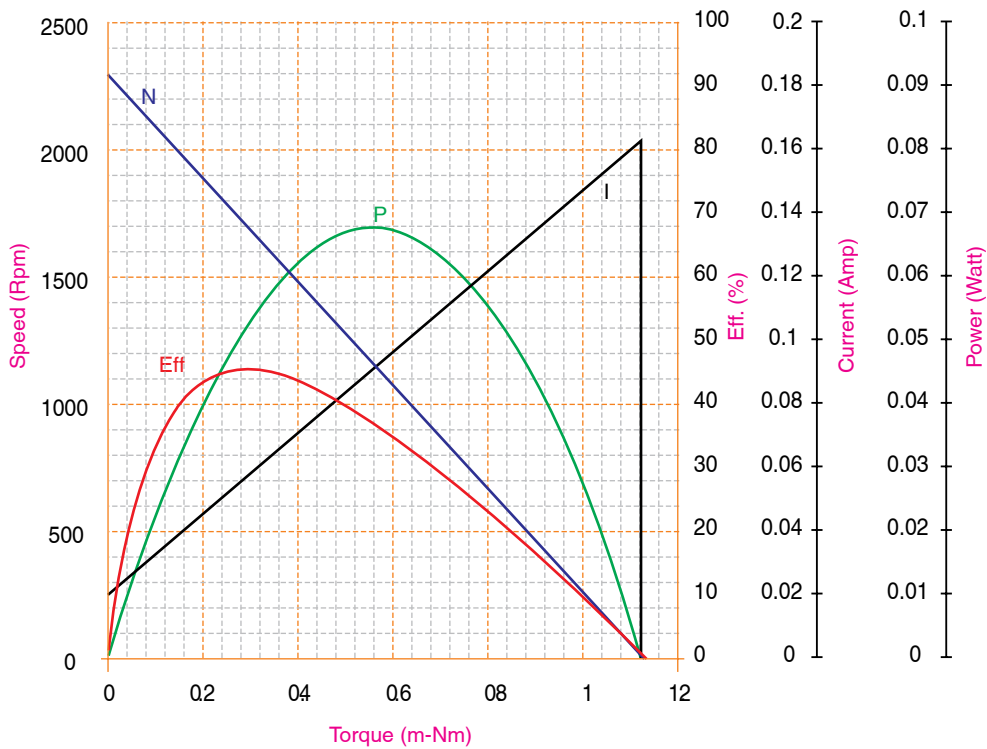

## Market

Consumer Electronics

## Application:

Game Controller



This typical low speed motor has an eccentric/balancer to produce the feel of low spin vibration for game controllers. Feeling of vibration could be adjusted by different eccentric. This is also widely-used in popular game player controllers.

## Motor Characteristics:

Diameter	: 24.4 mm
Length	: 12.3 mm
Shaft Diameter	: 2 mm
Weight	: 30 g
Nominal Voltage	: 8 V
Torque Constant	: 19.6 m-Nm/A
Dynamic Resistance	: 54.054 Ohms
Motor Regulations	: 1530.612 Rpm/m-N
Pole Number	: 3

## Standard Data:

Operating Temperature	: -10 — 50°C
Storage Temperature	: -20 — 100°C
Mounting	: Any position
Electrical Connection	: Leadwire
Standards	: RoHS

## Electrical Performance:

	No Load	Stall	Max Eff	Max Power
Speed (Rpm)	4200		3408	2100
Current (A)	0.008	0.148	0.034	0.078
Torque (mNm)		2.744	0.518	1.372
Efficiency (%)			58.91	
Power (W)			0.185	0.302

## Drawing:

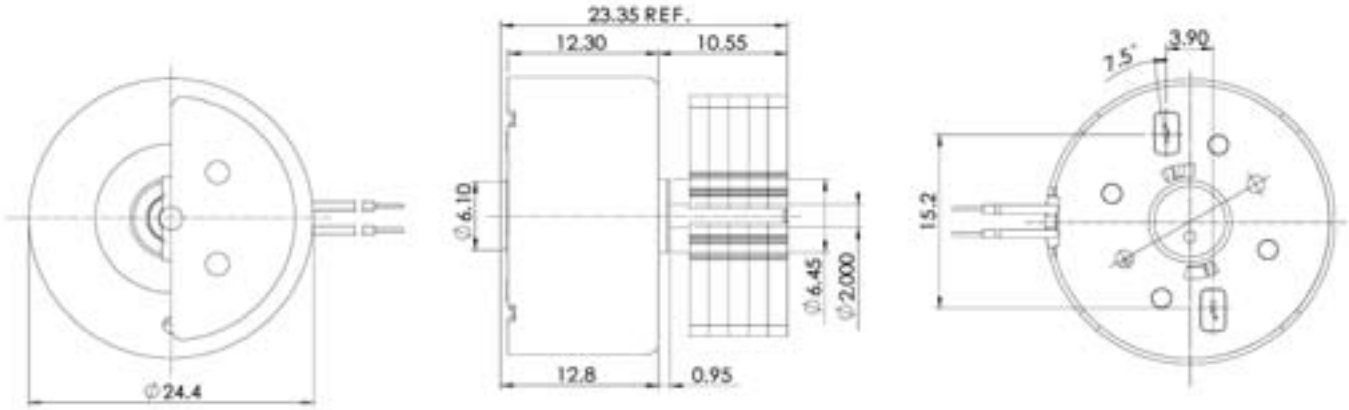

Unit in mm

## Performance Data:

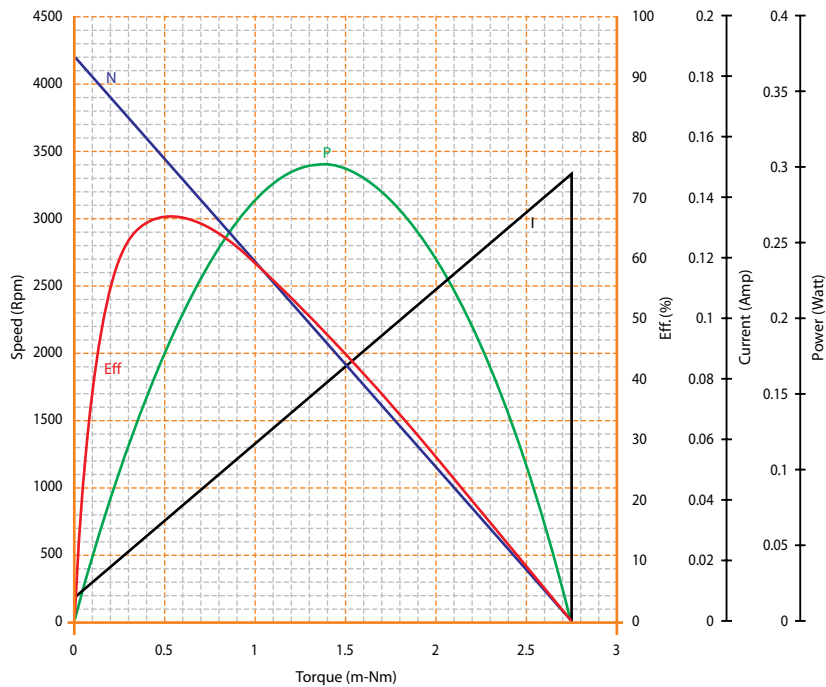

## Market

Consumer Electronics

## Application:

Portable CD/DVD Player

## Motor Characteristics:

Diameter	: 24.4 mm
Length	: 12.3 mm
Shaft Diameter	: 2 mm
Weight	: 23.6 g
Nominal Voltage	: 3 V
Torque Constant	: 7.259 m-Nm/A
Dynamic Resistance	: 11.163 Ohms
Motor Regulations	: 1992.347 Rpm/m-Nm
Pole Number	: 3



This motor can be used in CD/DVD player, also supplied with turntables for a total spindle solution

## Standard Data:

Operating Temperature	: -10 — 50°C
Storage Temperature	: -20 — 100°C
Mounting	: Any position
Electrical Connection	: Leadwire
Standards	: RoHS

## Electrical Performance:

	No Load	Stall	Max Eff	Max Power	At Torque
Speed (Rpm)	3612		2853	1806	2831
Current (A)	0.019	0.269	0.071	0.144	0.073
Torque (mNm)		1.813	0.381	0.906	0.392
Efficiency (%)			53.10		53.09
Power (W)			0.114	0.172	0.116



## Drawing:

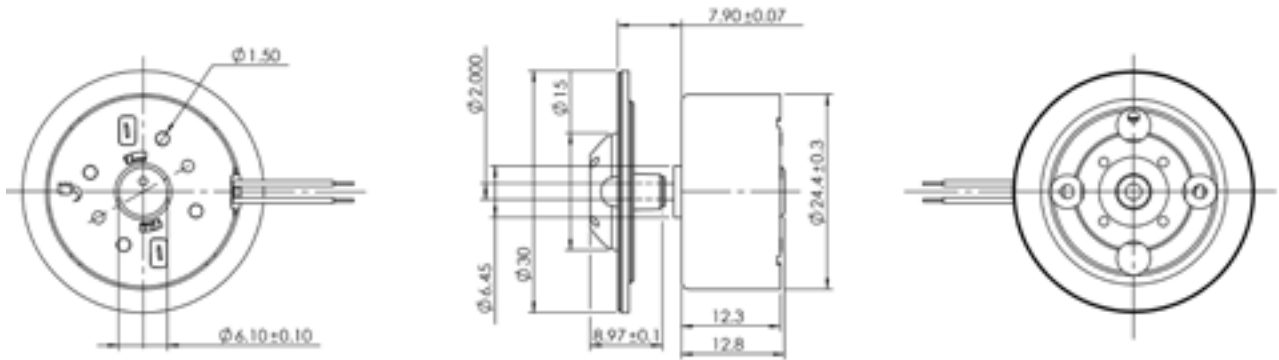

Unit in mm

PMDC

## Performance Data:

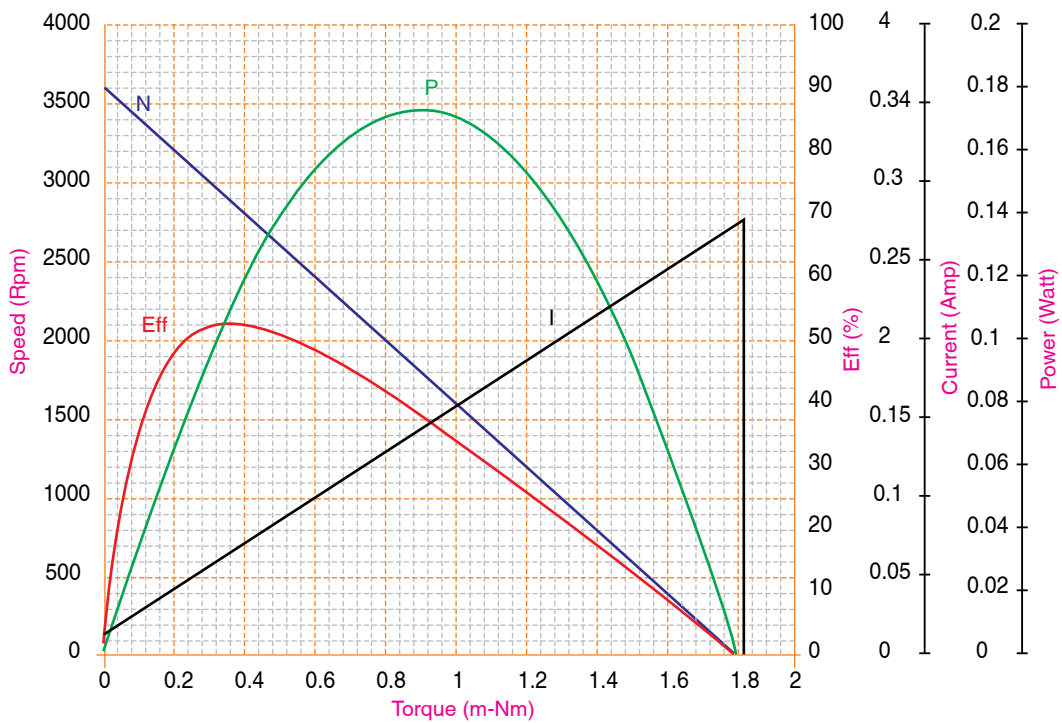

## Market

Business Machines

## Application:

Printer, Scan-

## Motor Characteristics:

Diameter	: 24.4 mm
Length	: 30.8 mm
Shaft Diameter	: 2 mm
Weight	: 51.5 g
Nominal Voltage	: 12 V
Torque Constant	: 12.805 m-Nm/A
Dynamic Resistance	: 5.856 Ohms
Motor Regulations	: 316.361 Rpm/m-Nm
Pole Number	: 3



Compact, low cost, with EMI suppression and high performance motor for paper feeder application in printer

## Standard Data:

Operation Temperature	: -10 — 55°C
Storage Temperature	: -20 — 100°C
Mounting	: Any position
Electrical Connection	: Terminal
Winding Temperature (Tmax)	: 130 °C
Direction of Rotation	: CCW
Standards	: RoHS
Remarks	: Varistor

## Electrical Performance:

	No Load	Stall	Max Eff	Max Power
Speed (Rpm)	8000		6700	4000
Current (A)	0.079	2.049	0.403	1.064
Torque (mNm)		25.22	4.15	12.61
Efficiency (%)			59.87	
Power (W)			2.897	5.271

## Drawing:

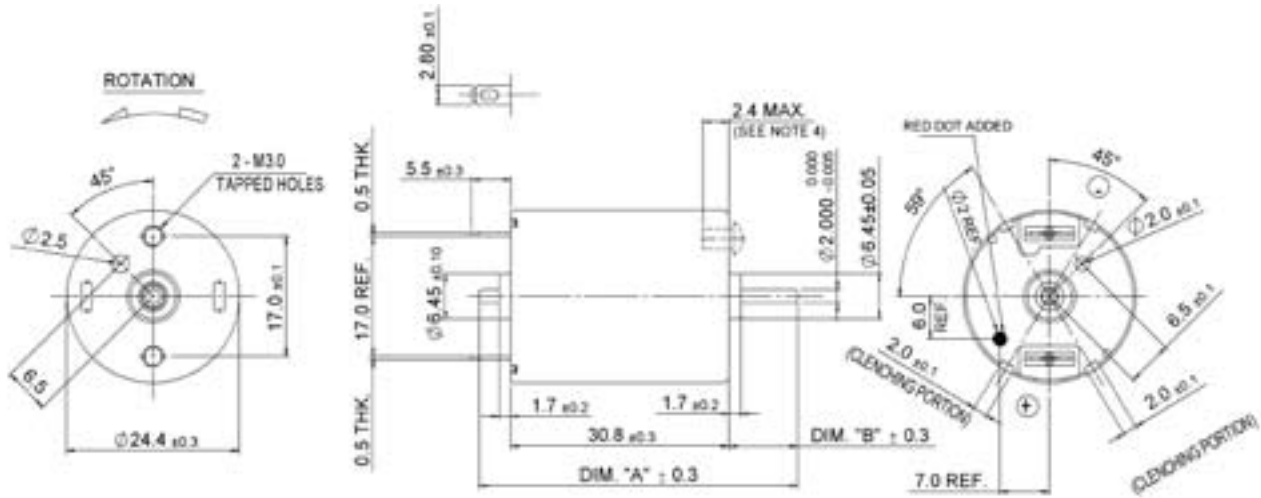

Unit in mm

## Performance Data:

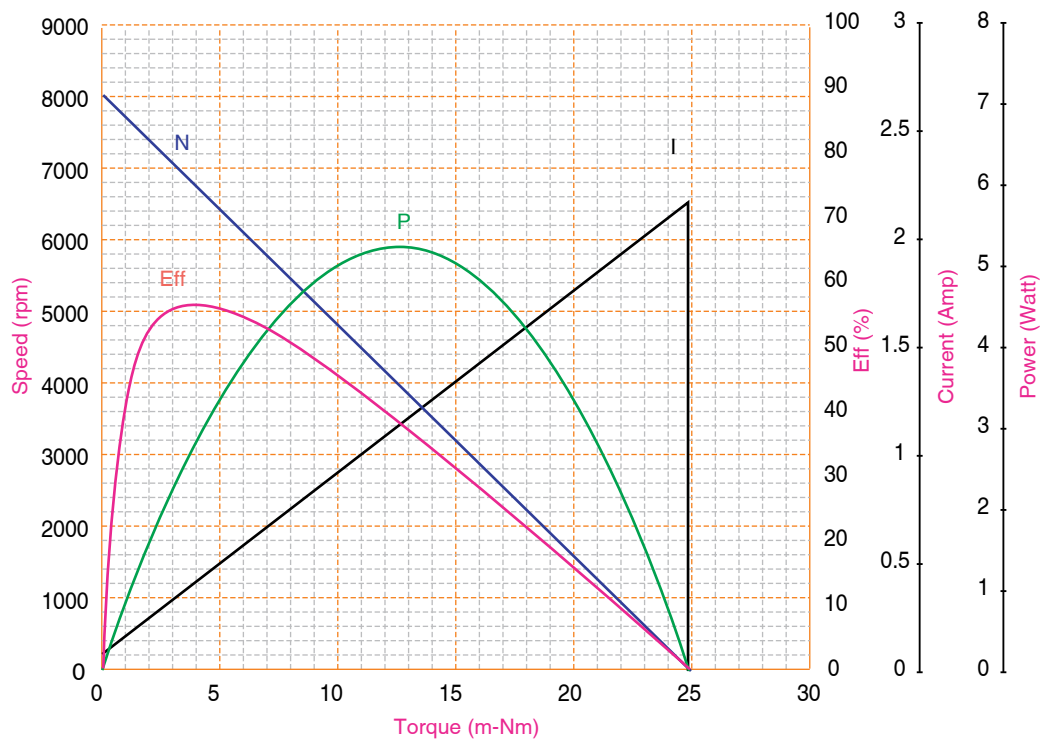

## Market

Consumer Electronics

## Application:

Portable CD /Car CD Player



Designed for spindle application

## Motor Characteristics:

Diameter	: 24.4 mm
Length	: 9 mm
Shaft Diameter	: 2 mm
Nominal Voltage	: 2 V
Weight	: 16 g
Torque Constant	: 4.876 m-Nm/A
Dynamic Resistance	: 10.954 Ohms
Motor Regulations	: 4601.02 Rpm/m-Nm
Pole Number	: 3

## Standard Data:

Operating Temperature	: -10 — 50°C
Storage Temperature	: -20 — 100°C
Mounting	: Any position
Electrical Connection	: Leadwire
Standards	: RoHS

## Electrical Performance:

	No Load	Stall	Max Eff	Max Power
Speed (Rpm)	3500		2536	1751
Current (A)	0.027	0.183	0.070	0.105
Torque (mNm)		0.761	0.210	0.381
Efficiency (%)			40	
Power (W)			0.056	0.070

## Drawing:

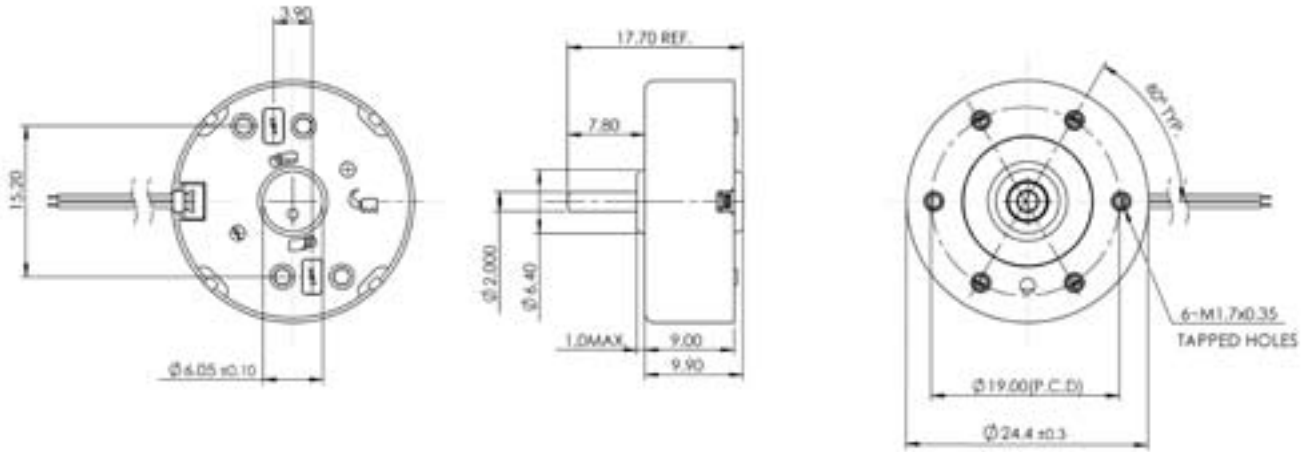

Unit in mm

## Performance Data:

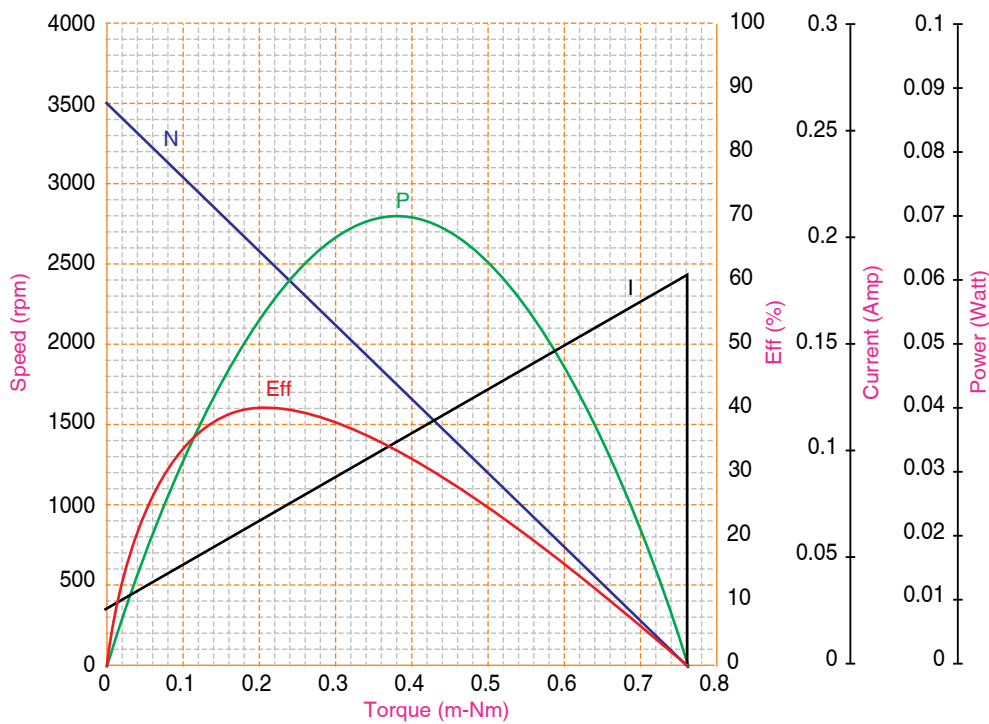

## Market

Power & Garden

## Application:

Drill

## Motor Characteristics:

Diameter	: 44.7 mm
Length	: 68.5 mm
Shaft Diameter	: 5.005 mm
Weight	: 440 g
Nominal Voltage	: 18 V
Torque Constant	: 7.869 m-Nm/A
Dynamic Resistance	: 0.156 Ohms
Motor Regulations	: 25.863 Rpm/m-Nm
Pole Number	: 5



This motor is developed for high torque and efficiency required on cordless power tool applications

## Standard Data:

Operation Temperature	: -10 — 50°C
Storage Temperature	: -20 — 100°C
Mounting	: Any position
Electrical Connection	: Terminal
Power Consumption	: 302.4 W
Power Output	: 237.436 W
Running Torque	: 117.389 cNm
Direction of Rotation	: CCW
Standards	: RoHS

## Electrical Performance:

	No Load	Stall	Max Eff	Max Power
Speed (Rpm)	22900		19900	11500
Current (A)	2.68	115.203	17.571	58.942
Torque (mNm)		885.4152	117.17	442.71
Efficiency (%)			77.12	
Power			243.902	531.031

## Drawing:

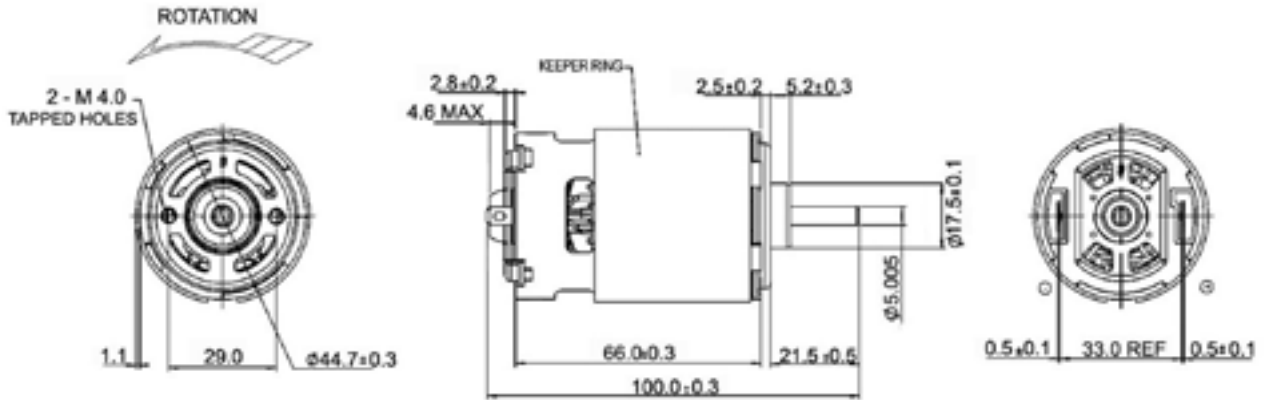

Unit in mm

## Performance Data:

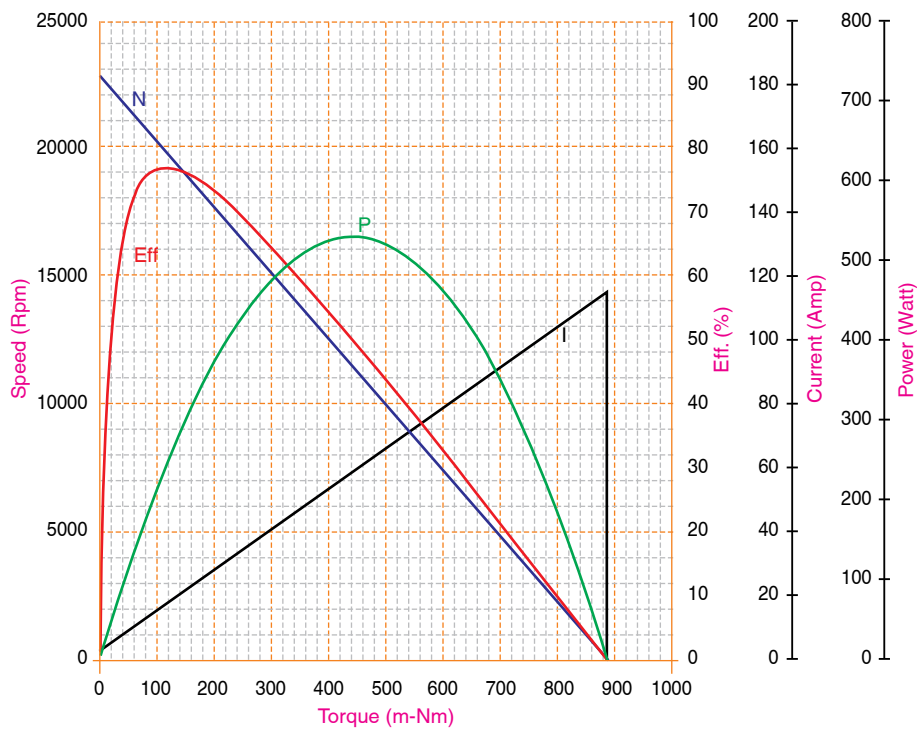







# High Voltage DC Motors

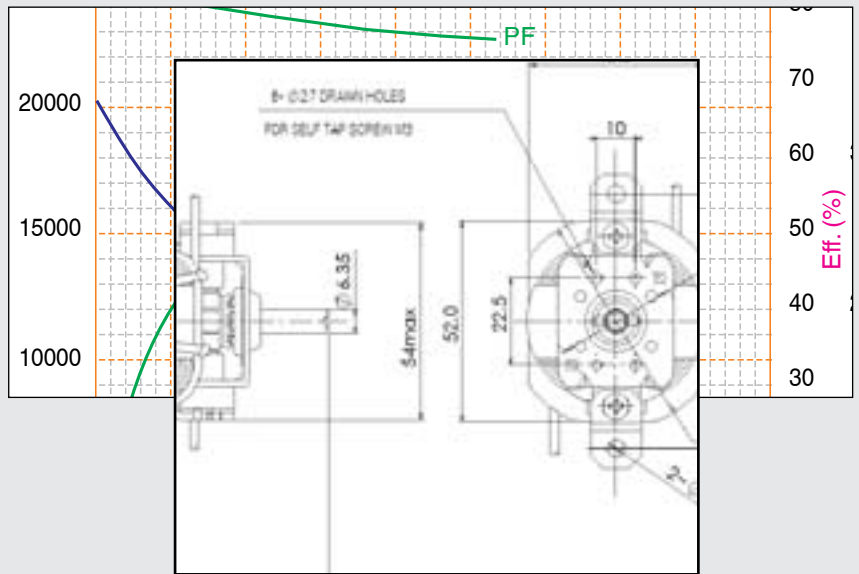

## Market

Personal Care

## Application:

Hair Clipper



Long life motor for hair clipper

## Motor Characteristics:

Diameter	: 35.8 mm
Length	: 57 mm
Shaft Diameter	: 3.175 mm
Weight	: 205 g
Nominal Voltage	: 120 V
Frequency	: 60 Hz
Pole Number	: 8

## Standard Data:

Power Consumption	: 25 W
Power Output	: 10 W
Running Torque	: 20 cNm
Direction of Rotation	: CCW
Standards	: RoHS

## Electrical Performance:

	No Load	Rated Load	Max Eff	Max Power
Speed (Rpm)	7170	4700	4600	3200
Current (A)	0.09	0.210	0.22	0.31
Torque (mNm)		20.0	20.9	37.37
Efficiency (%)			39.86	
Input Power (W)		25.0	25.40	
Output Power (W)		10.0		12.56

## Drawing:

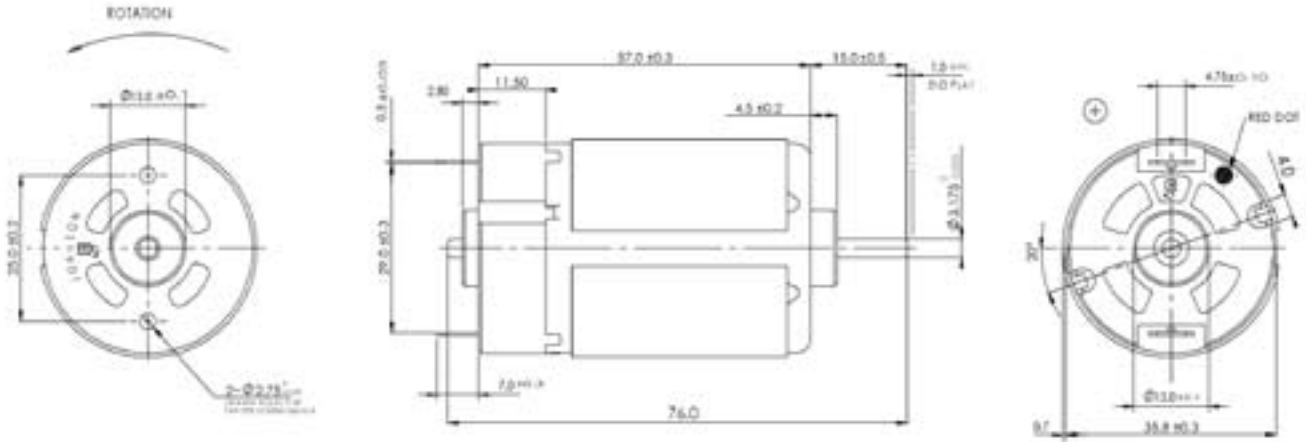

Unit in mm

## Performance Data:

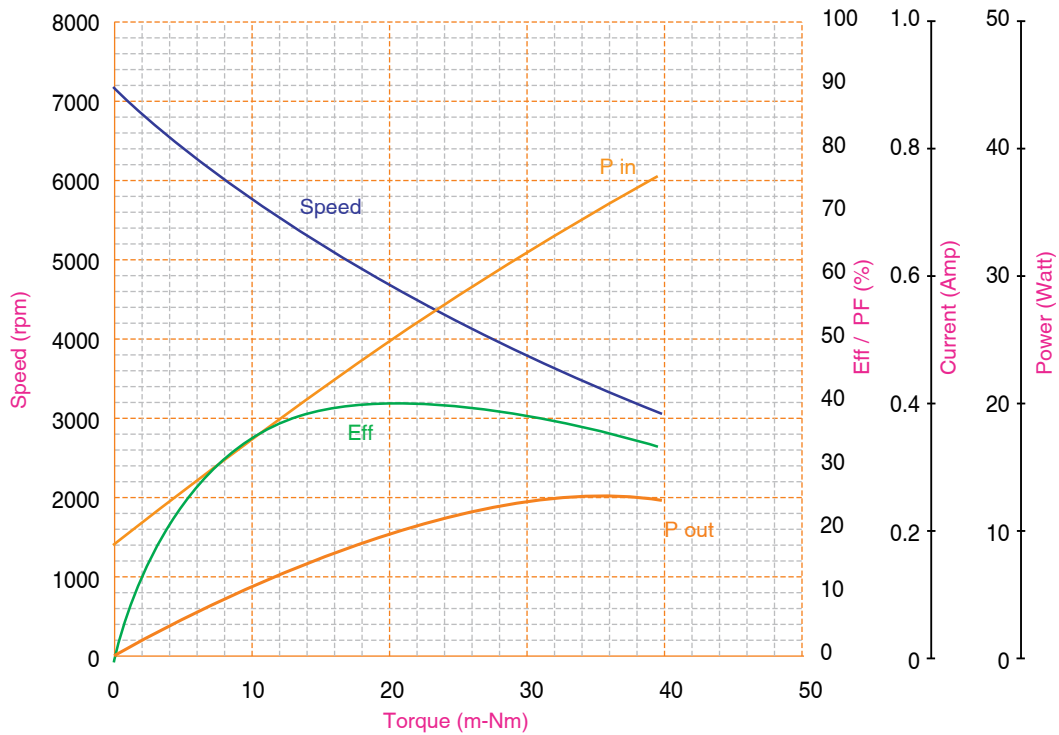

## Market

Personal Care

## Application:

Hair Clipper



Long life motor for hair clipper

## Motor Characteristics:

Diameter	: 35.8 mm
Length	: 57 mm
Shaft Diameter	: 3.175 mm
Weight	: 220 g
Nominal Voltage	: 120 V
Frequency	: 60 Hz
Pole Number	: 12

## Standard Data:

Power Consumption	: 21 W
Power Output	: 11 W
Running Torque	: 25 m-Nm
Direction of Rotation	: CCW
Standards	: RoHS
Remarks	: Choke

## Electrical Performance:

	No Load	Rated Load	Max Eff	Max Power
Speed (Rpm)	6300	4500	4500	2800
Current (A)	0.03	0.160	0.16	0.32
Torque (mNm)		20.0	19.38	49.77
Efficiency (%)			52.85	
Input Power (W)		17.50	17.20	
Output Power (W)		9.110		14.43

## Drawing:

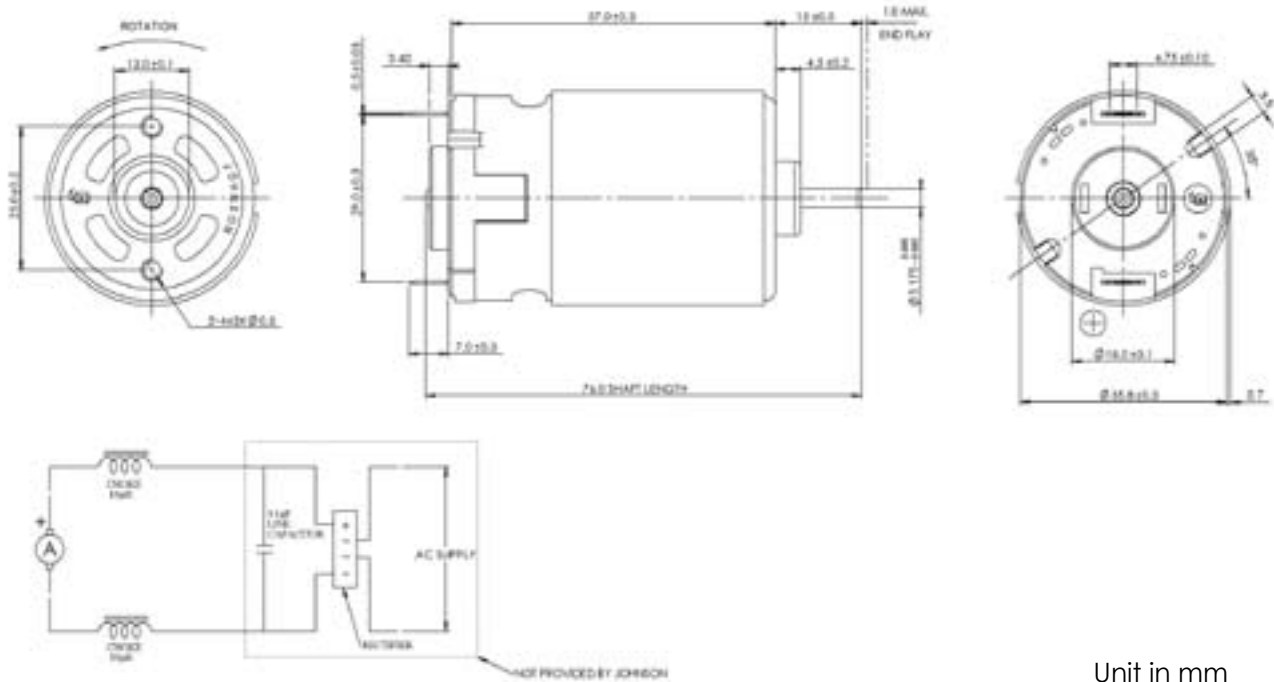

HVDC

## Performance Data:

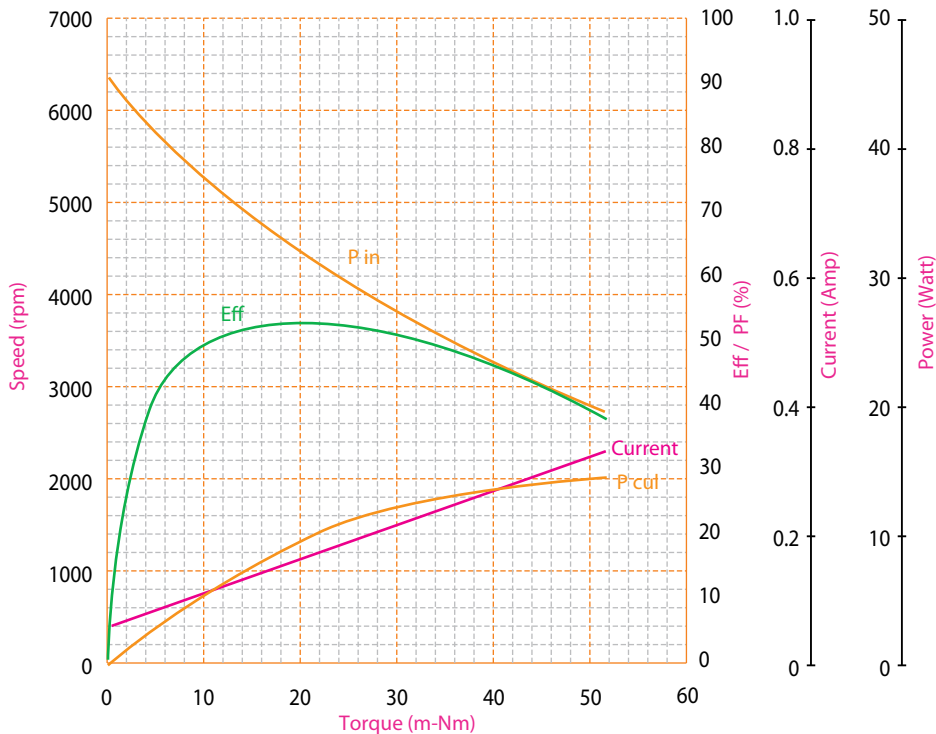

## Market

Home Appliances

## Application:

Sewing Machine



This high efficiency motor is specially designed for 230 v sewing machine

## Motor Characteristics:

Diameter	: 35.8 mm
Length	: 57 mm
Shaft Diameter	: 3.175 mm
Weight	: 180 g
Nominal Voltage	: 120 V
Frequency	: 60 Hz
Pole Number	: 2

## Standard Data:

Operation Temperature	: -10 — 55°C
Storage Temperature	: -20 — 100°C
Mounting	: Any position
Electrical Connection	: Terminal
Winding Temperature (Tmax)	: 180 °C
Direction of Rotation	: CCW
Approvals	: UL
Certifications	: E60303

## Electrical Performance:

	No Load	Stall	Rated Load	Max Eff	Max Power
Speed (Rpm)	10600		7600	7627	4725
Current (A)	0.084	0.91	0.28	0.29	0.54
Torque (mNm)		87.5	20.08	20.24	47
Efficiency (%)				53.08	
Input Power (W)	8.36		30.76	30.58	
Output Power (W)			16.24	16.23	22.9

## Drawing:

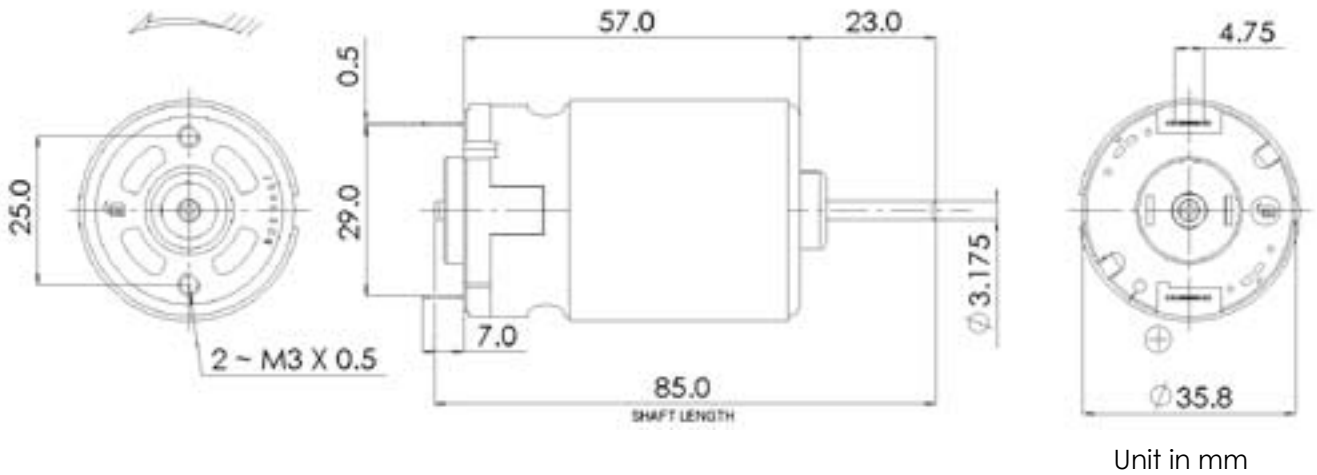

## Performance Data:

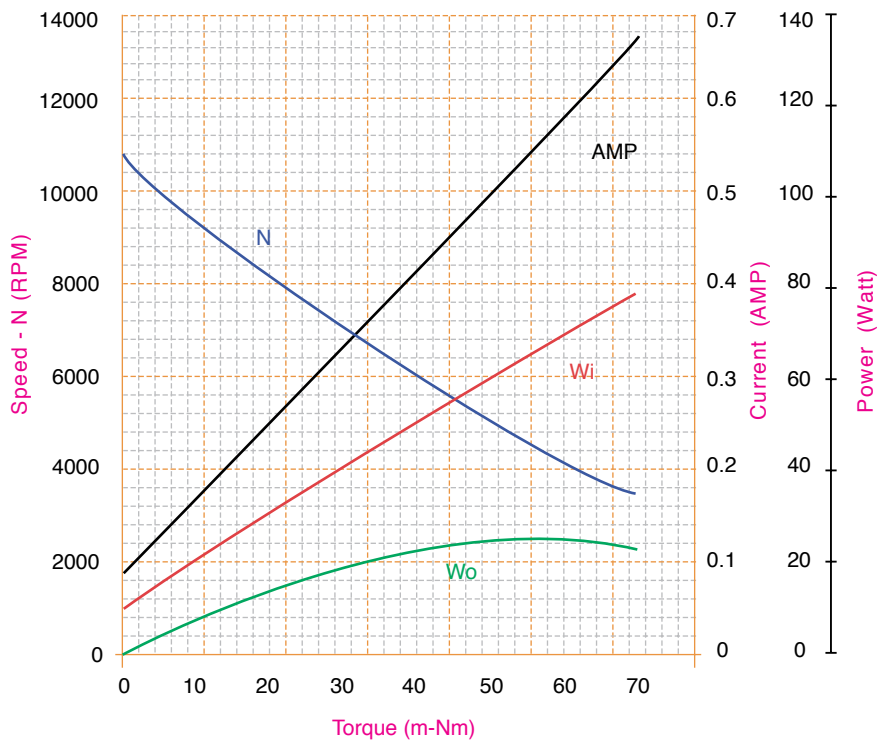

## Market

Home Appliances

## Application:

Sewing Machine



This high efficiency motor is specially designed for 230 v sewing machine

## Motor Characteristics:

Diameter	: 35.8 mm
Length	: 57 mm
Shaft Diameter	: 3.175 mm
Weight	: 180 g
Nominal Voltage	: 230 V
Frequency	: 50 Hz
Pole Number	: 2

## Standard Data:

Operation Temperature	: -10 — 55°C
Storage Temperature	: -20 — 100°C
Mounting	: Any position
Electrical Connection	: Terminal
Winding Temperature (Tmax)	: 180 °C
Direction of Rotation	: CCW

## Electrical Performance:

	No Load	Stall	Rated Load	Max Eff	Max Power
Speed (Rpm)	15660		10439	11269	7830
Current (A)	0.064	0.71	0.26	0.23	0.39
Torque (mNm)		83.51	25	20	41
Efficiency (%)				49.36	
Input Power (W)	13.08		56.85	48.10	
Output Power (W)			27.25	23.74	33.3



## Drawing:

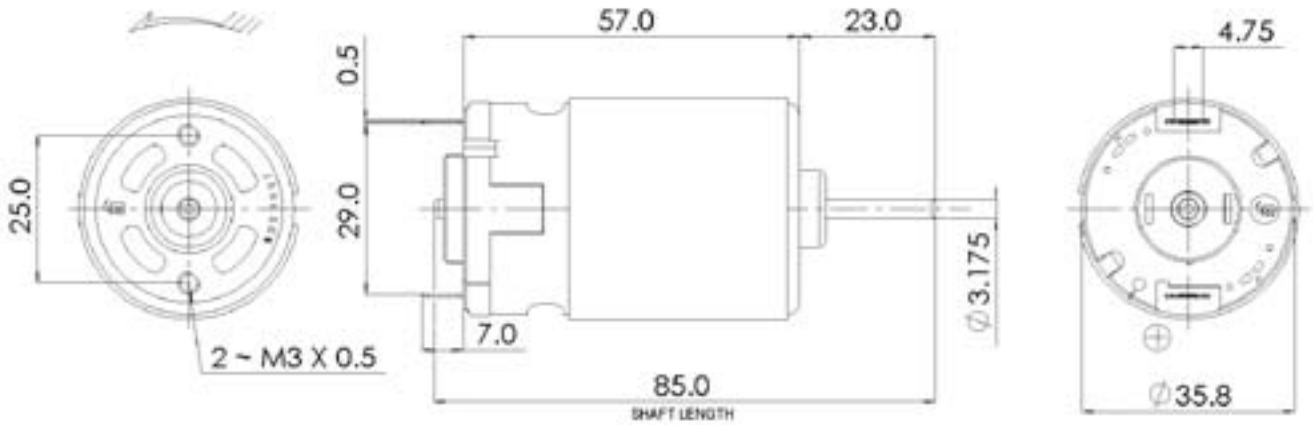

Unit in mm

HVDC

## Performance Data:

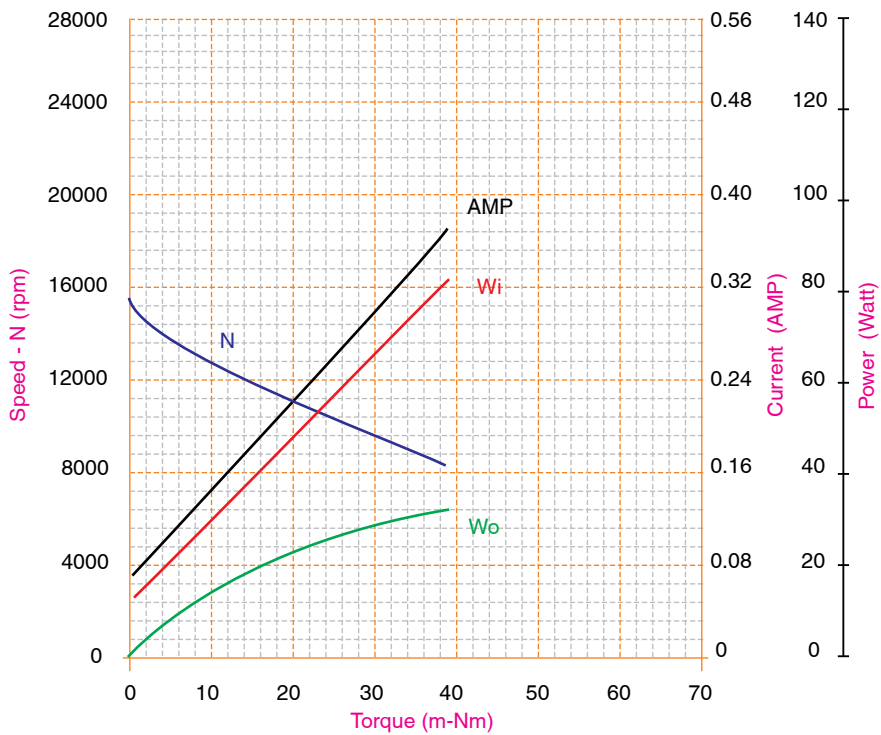

## Market

Floor Care

## Application:

Power Brush

## Motor Characteristics:

Diameter : 42.5 mm  
Length : 75.6 mm  
Shaft Diameter : 5.0 mm  
Weight : 416 g  
Nominal Voltage : 120 V  
Frequency : 60 Hz  
Pole Number : 2



This DC771 series is available in different powers and shaft features. It has high efficiency suitable for power brush and brush roll applications.

## Standard Data:

Operation Temperature : -10 — 55°C  
Storage Temperature : -20 — 100°C  
Mounting : Any position  
Electrical Connection : Terminal  
Winding Temperature (Tmax) : 180 °C  
Direction of Rotation : CW (View from input end)  
Standards : UL, E60303

## Electrical Performance:

	No Load	Max Eff
Speed (Rpm)	11692	8497
Current (A)	0.28	1.17
Torque (mNm)		88
Efficiency (%)		61.94
Power (W)		78.51

## Drawing:

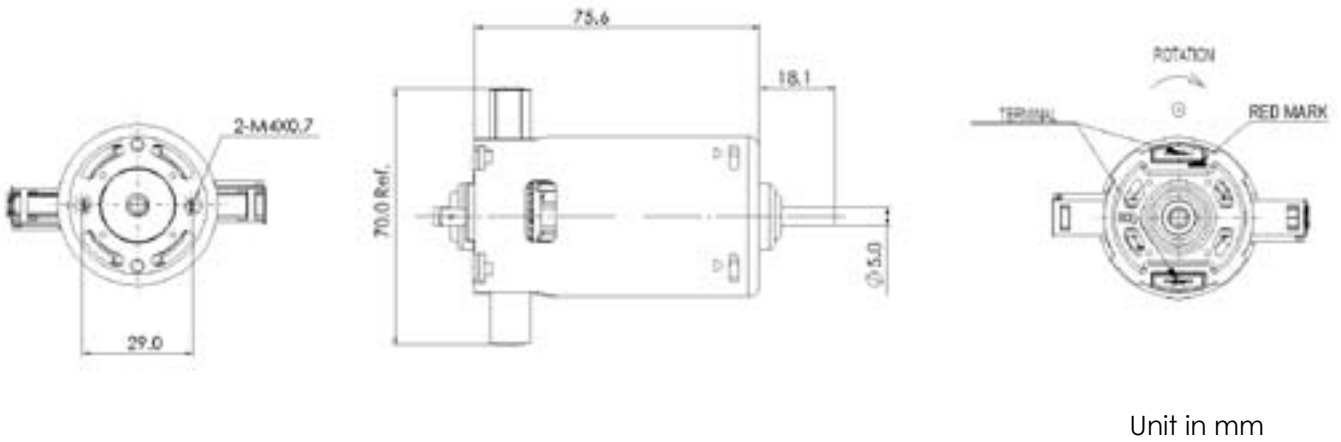

HVDC

## Performance Data:

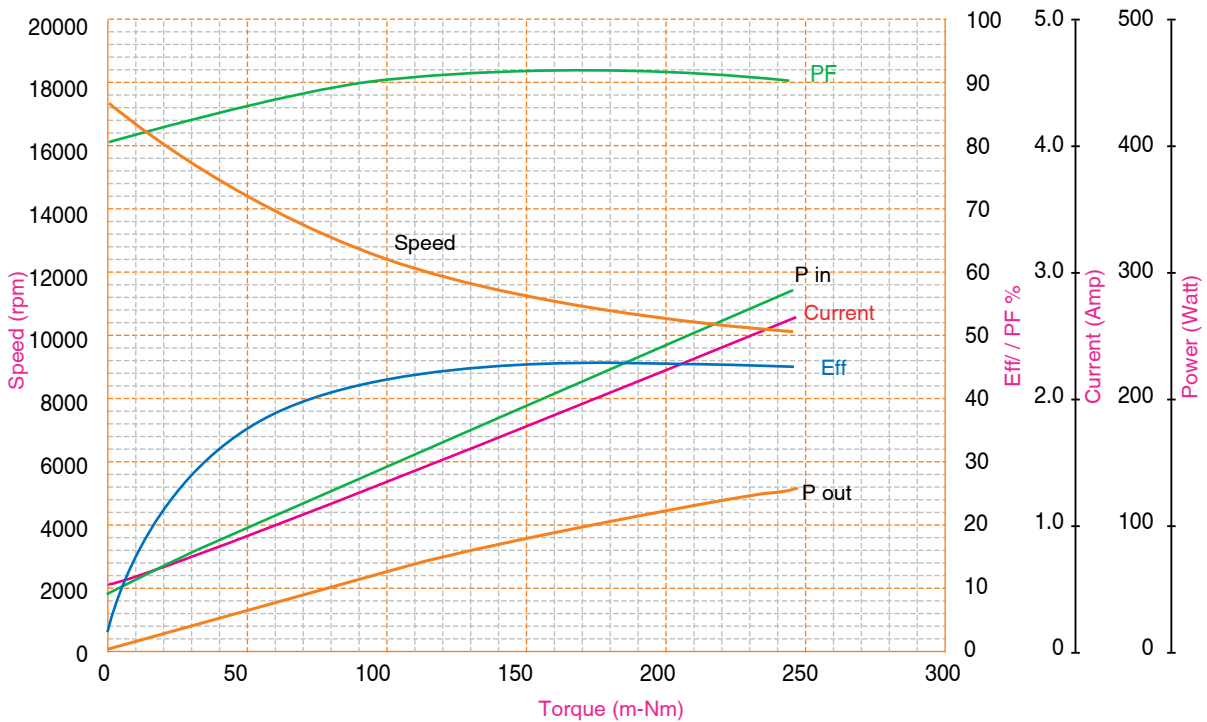

## Market

Power & Garden Tools

## Application:

Hedge Trimmer



This HVDC motor has excellent power to weight ratio needed for the hedge trimmer

## Motor Characteristics:

Diameter	: 42.5 mm
Length	: 66 mm
Shaft Diameter	: 5.005 mm
Weight	: 300 g
Nominal Voltage	: 100 V
Frequency	: 60 Hz
Pole Number	: 12

## Standard Data:

Operation Temperature	: -10 — 50°C
Storage Temperature	: -20 — 100°C
Mounting	: Any position
Electrical Connection	: Leadwire
Power Consumption	: 105.0 W
Power Output	: 53.0 W
Running Torque	: 30.0 mNm
Direction of Rotation	: CW
Standards	: RoHS

## Electrical Performance:

	No Load	Rated Load	Max Eff	Max Power
Speed (Rpm)	18700	14600	13400	8700
Current (A)	0.43	1.08	1.67	3.17
Torque (mNm)		30.0	59.47	145.1
Efficiency (%)			56.42	
Input Power (W)		105.0	148.78	
Output Power (W)		53.0	83.94	131.02

## Drawing:

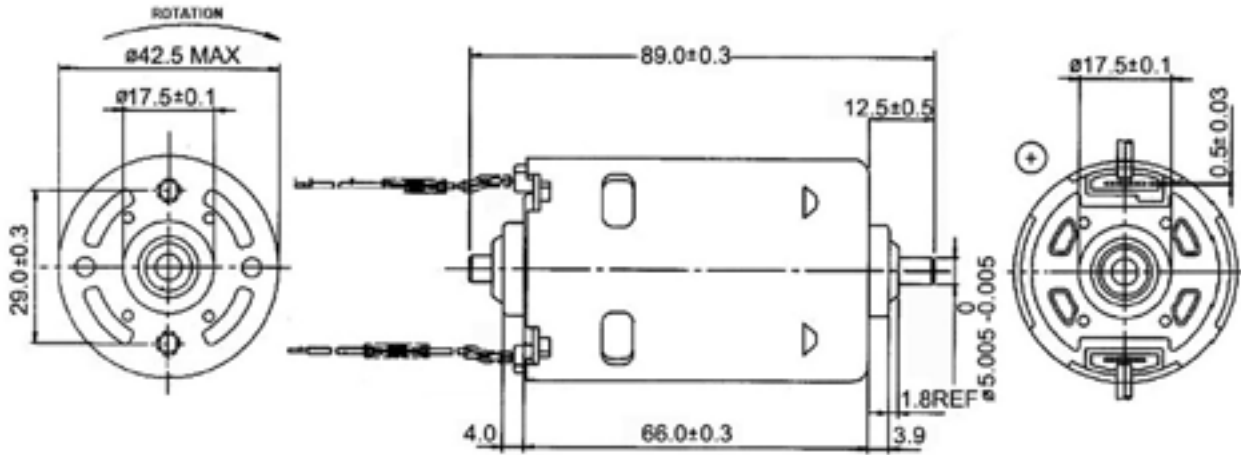

Unit in mm

HVDC

## Performance Data:

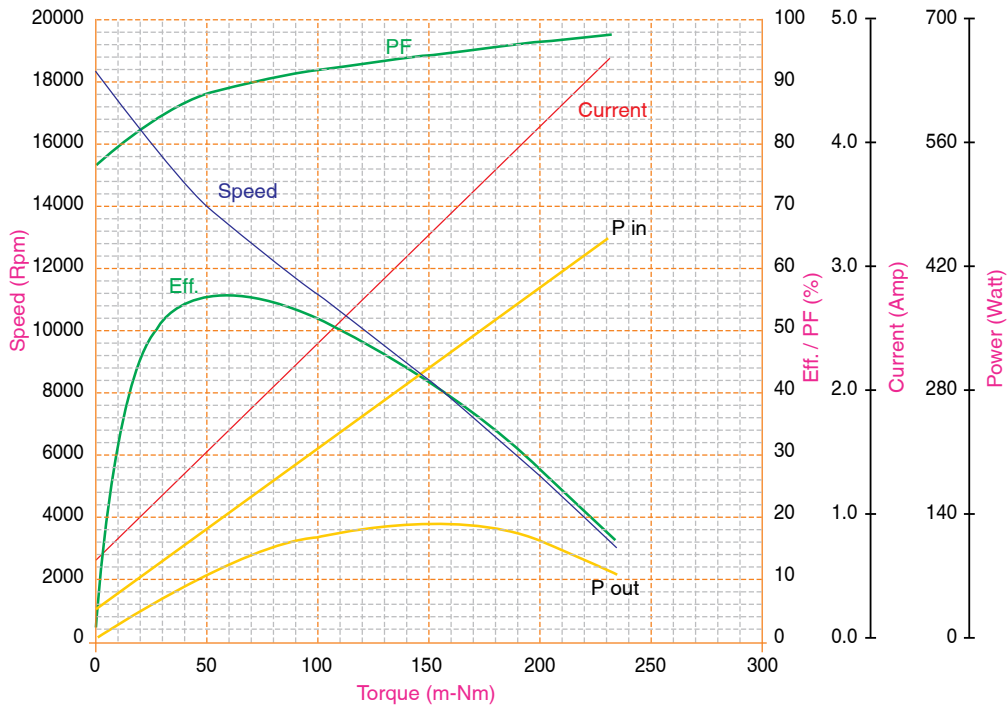

## Market

Home Appliances

## Application:

Coffee Grinder



This specially designed motor is for coffee grinder

## Motor Characteristics:

Diameter	: 42.5 mm
Length	: 66 mm
Shaft Diameter	: 5 mm
Weight	: 291 g
Nominal Voltage	: 230 V
Frequency	: 50 Hz with Rectifier
Pole Number	: 2

## Standard Data:

Operation Temperature	: -10 — 55°C
Storage Temperature	: -20 — 100°C
Mounting	: Any position
Electrical Connection	: Terminal
Winding Temperature (Tmax)	: 140 °C
Direction of Rotation	: CW

## Electrical Performance:

	No Load	Rated Load	Max Eff	Max Power
Speed (Rpm)	18195	16200	13160	8921
Current (A)	0.17	0.39	0.7	1.21
Torque (mNm)		18	56.9	126.5
Efficiency (%)		44	56.2	40.3
Input Power (W)	27.1	80	130	260
Output Power (W)		32	80.1	115.5

Drawing:

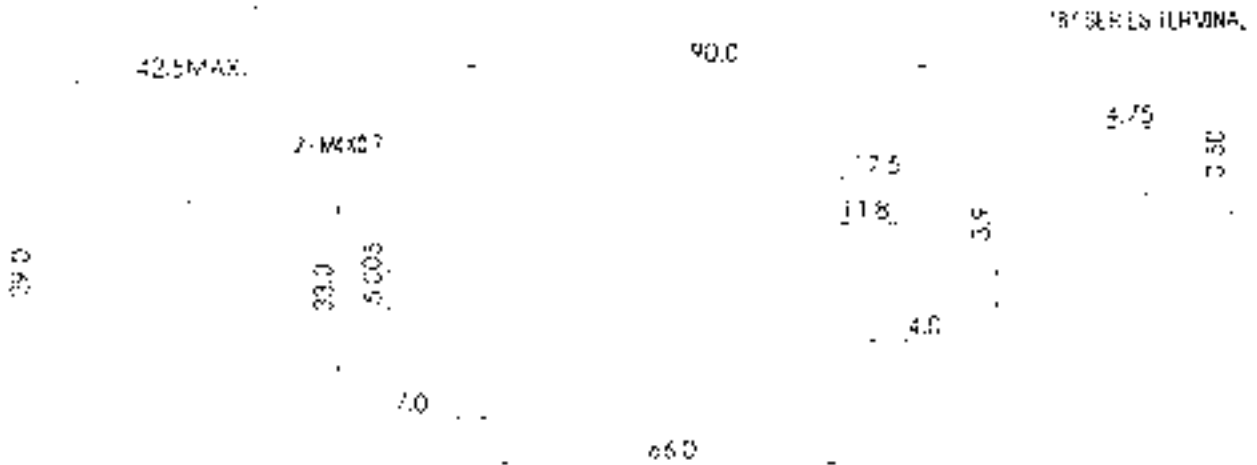

Unit in mm

HVDC

Performance Data:

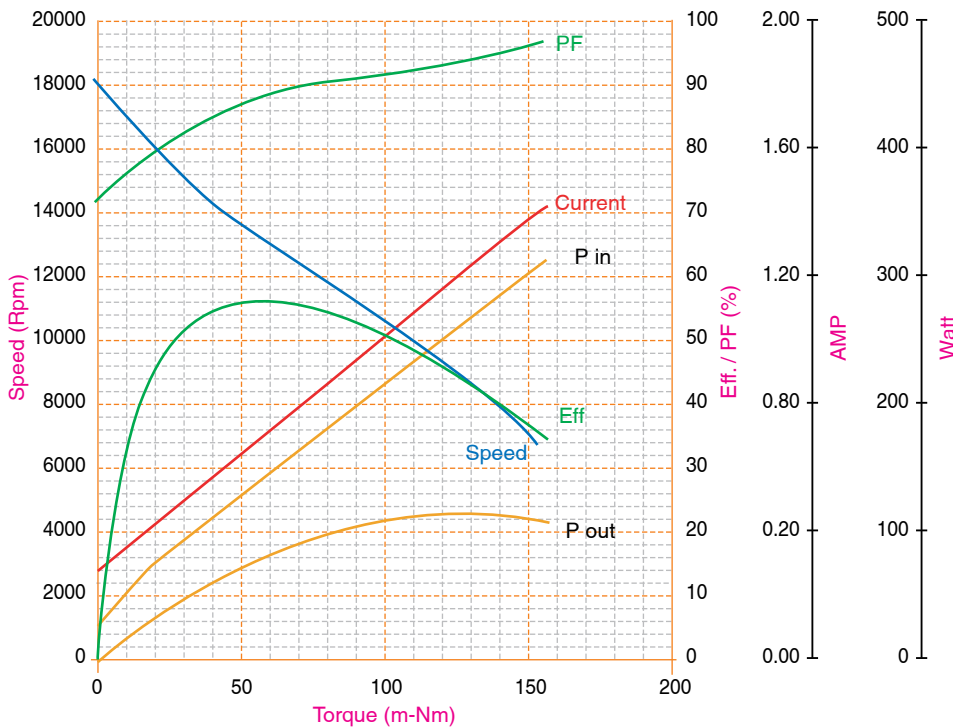

## Market

Floor Care, Home Appliances

## Application:

Power Brush, Stick Blender



This high voltage DC motor can be widely used for power brush, and stick blender application.

## Motor Characteristics:

Diameter	: 42.4 mm
Length	: 75.6 mm
Weight	: 357.7 g
Shaft Diameter	: 5 mm
Nominal Voltage	: 120 V
Frequency	: 60 hz

## Standard Data:

Operation Temperature	: -10 — 55°C
Storage Temperature	: -20 — 100°C
Mounting	: Any position
Electrical Connection	: Terminal
Winding Temperature (Tmax)	: 130 °C
Direction of Rotation	: CCW

## Electrical Performance:

	No Load	Rated Load	Max Eff	Max Power
Speed (Rpm)	12702	11300	9363	5451
Current (A)	0.2	0.5	1.01	2.23
Torque (mNm)		14	68.91	197.24
Efficiency (%)			63.42	46.6
Input Power (W)		40		
Output Power (W)		21	67.61	117.15



Drawing:

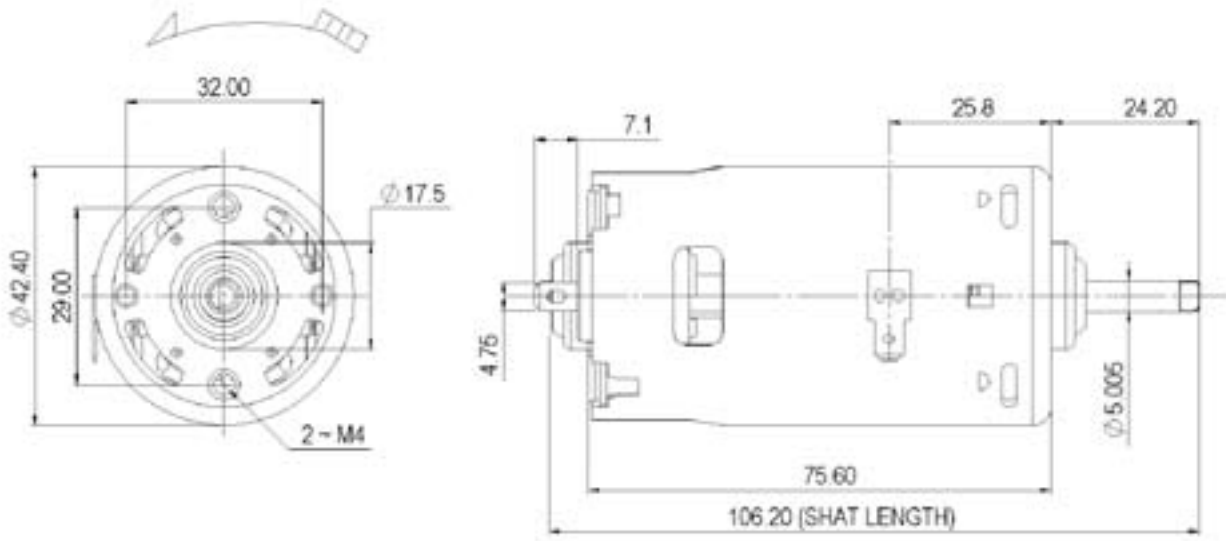

Unit in mm

Performance Data:

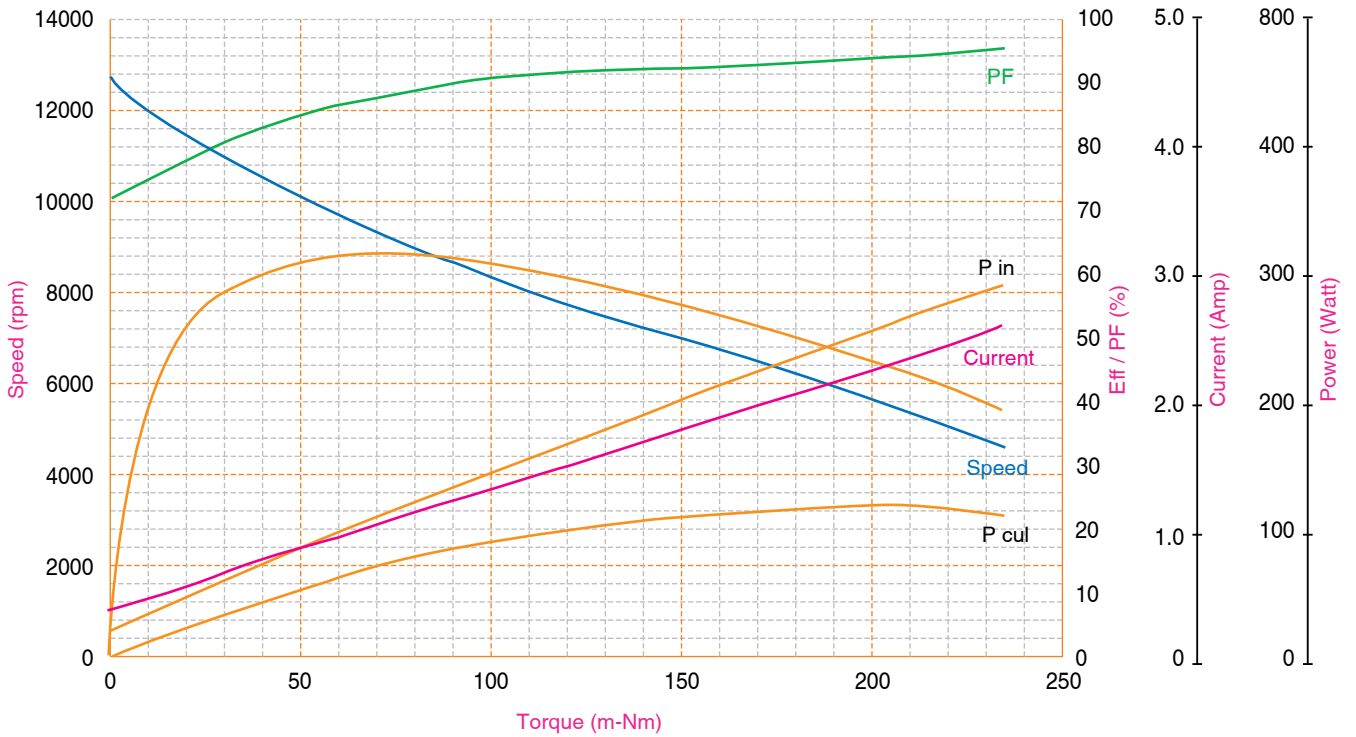

## Market

Floor Care

## Application:

Power Brush



This motor is optimized to be used in high power application

## Motor Characteristics:

Diameter	: 42.2 mm (without keeper ring)
Length	: 133.3 mm
Shaft Diameter	: 5 mm
Weight	: 377 g
Nominal Voltage	: 120 V
Frequency	: 60 hz

## Standard Data:

Operation Temperature	: -10 — 55°C
Storage Temperature	: -20 — 100°C
Mounting	: Any position
Electrical Connection	: Terminal
Winding Temperature (Tmax)	: 130 °C
Direction of Rotation	: CW (view from input end)
Standards	: UL, E60303

## Electrical Performance:

	No Load	Max Eff	Max Power
Speed (Rpm)	11600	7923	9096
Current (A)	0.25	1	0.76
Torque (mNm)		66.86	38
Efficiency (%)		51.22	46.18
Input Power (W)	23	1.10	75.03
Output Power (W)		56.55	34.65

## Drawing:

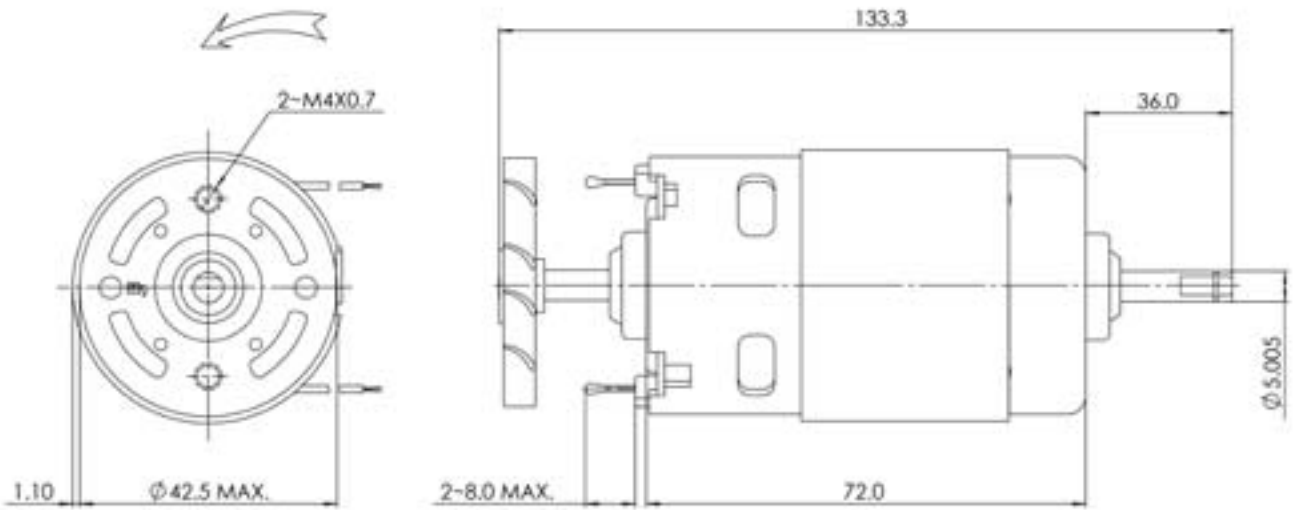

Unit in mm

HVDC

## Performance Data:

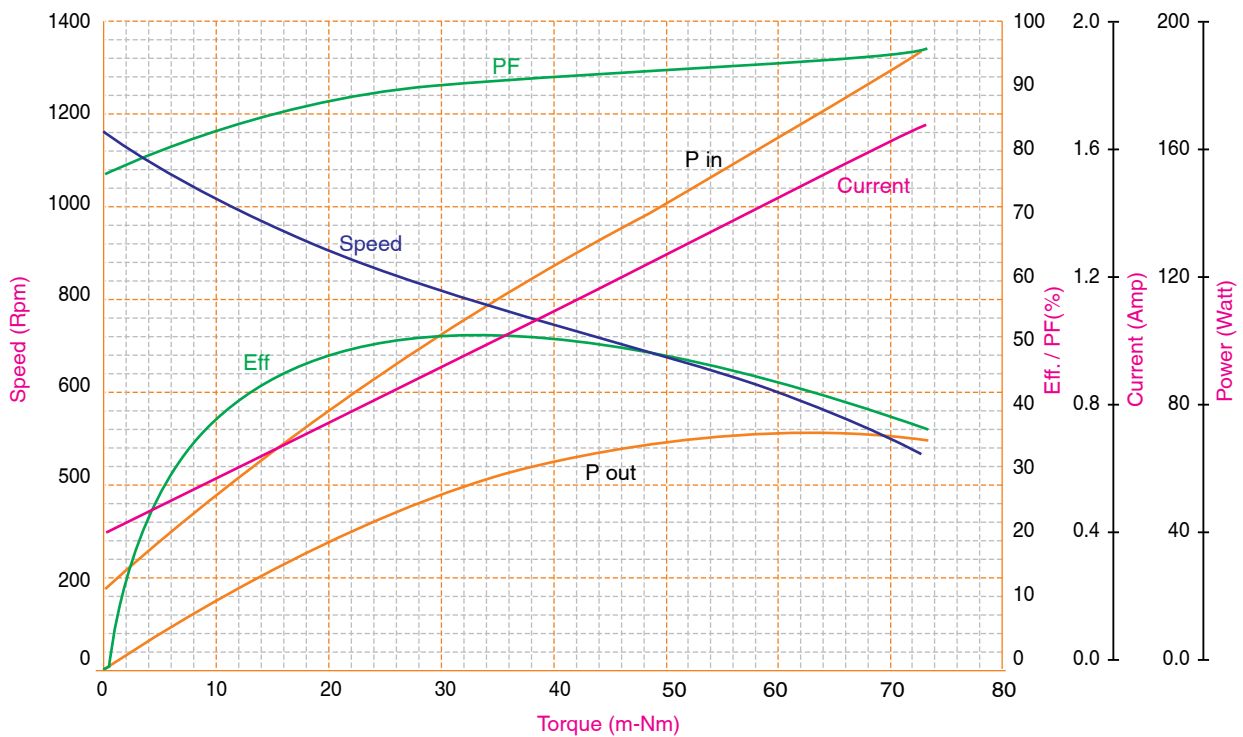

## Market

Floor Care

## Application:

Power Brush



This HVDC motor is specially designed for high power brush application with external mounting feature

## Motor Characteristics:

Length : 116 mm  
Shaft Diameter : 6.35 mm  
Weight : 795 g  
Nominal Voltage : 120 V  
Frequency : 60 Hz  
Pole Number : 2

## Standard Data:

Operation Temperature : -10 — 55°C  
Storage Temperature : -20 — 100°C  
Mounting : Any position  
Electrical Connection : Terminal  
Winding Temperature (Tmax) : 180 °C  
Direction of Rotation : CCW  
Standards : UL, E60303

## Electrical Performance:

	No Load	Rated Load	Max Eff
Speed (Rpm)	11115	9174	8318
Current (A)	0.46	1.46	2.02
Torque (mNm)		100	156.56
Efficiency (%)		63.73	64.99
Input Power (W)		147.53	240.07
Output Power (W)		94.02	137.03

## Drawing:

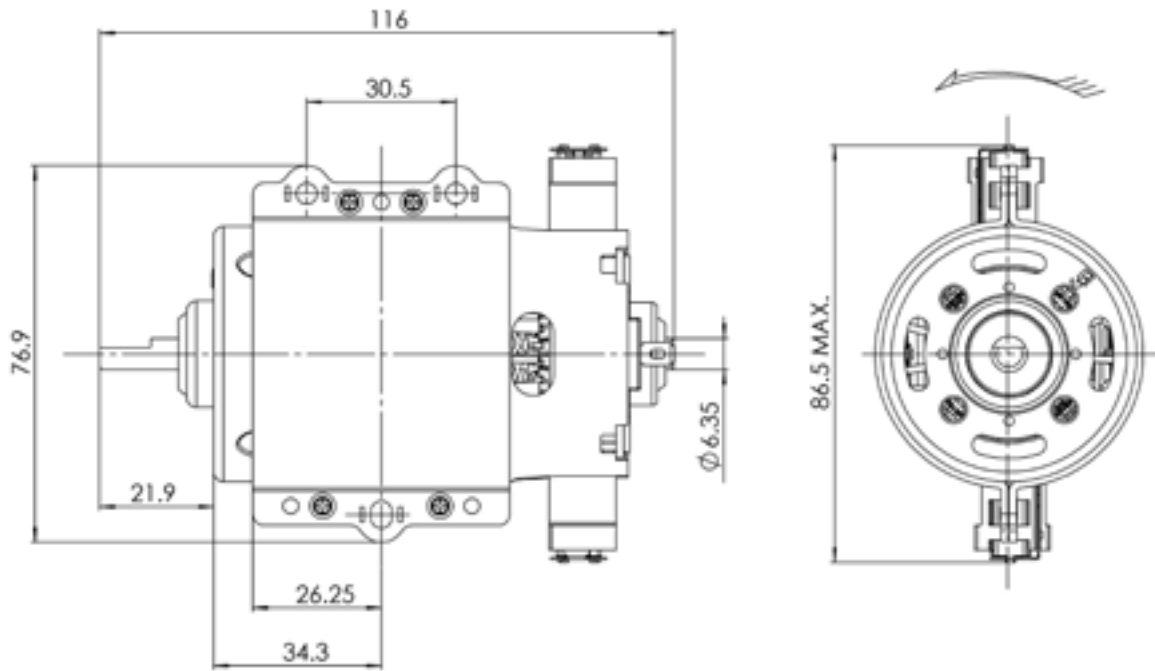

Unit in mm

## Performance Data:

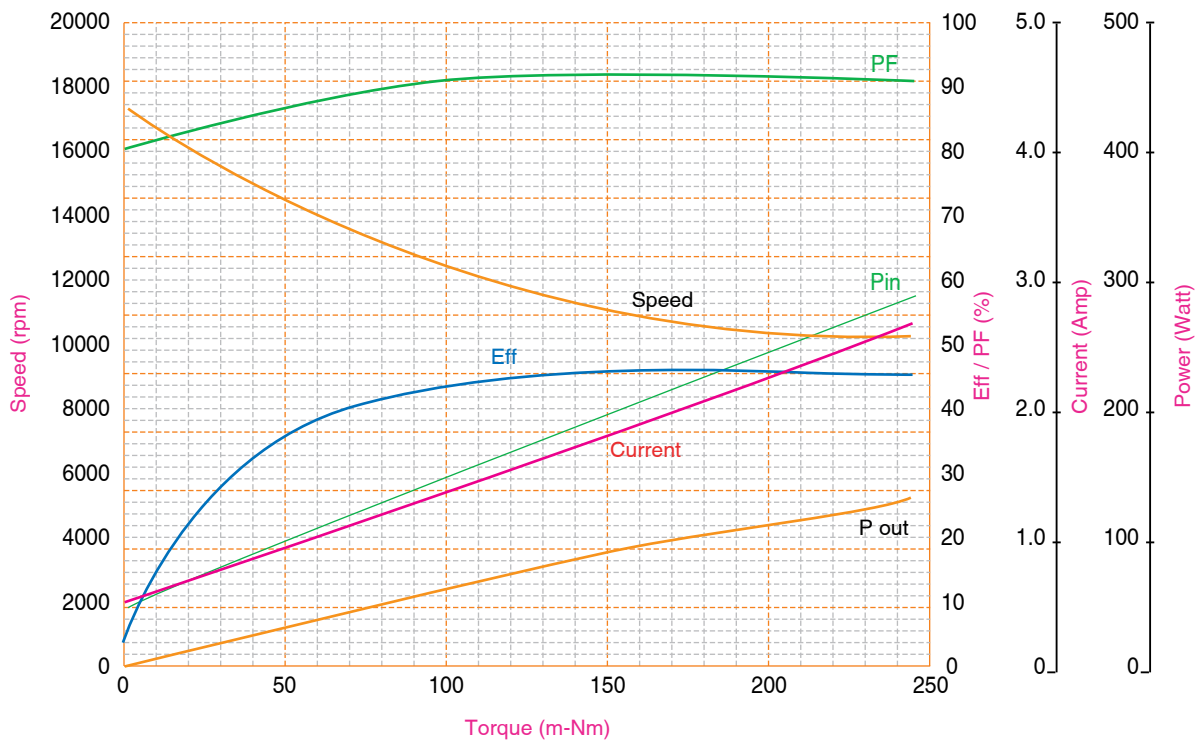

## Market

Floor Care

## Application:

Power Brush



This HVDC motor is specially designed for high power brush application with shaft pinion feature

## Motor Characteristics:

Diameter	: 52.4 mm
Length	: 122 mm
Shaft Diameter	: 6.35 mm
Weight	: 650 g
Nominal Voltage	: 120 V
Frequency	: 60 Hz

## Standard Data:

Operation Temperature	: -10 — 55°C
Storage Temperature	: -20 — 100°C
Mounting	: Any position
Electrical Connection	: Terminal
Winding Temperature (Tmax)	: 130 °C
Direction of Rotation	: CW
Standards	: UL, E60303

## Electrical Performance:

	No Load	Max Eff	Rated Load
Speed (Rpm)	12583	8900	8899
Current (A)	0.53	2.4	2.46
Torque (mNm)		179	179.52
Efficiency (%)	49	63	63.52
Input Power (W)		270	269.96
Output Power (W)		180	168.5

## Drawing:

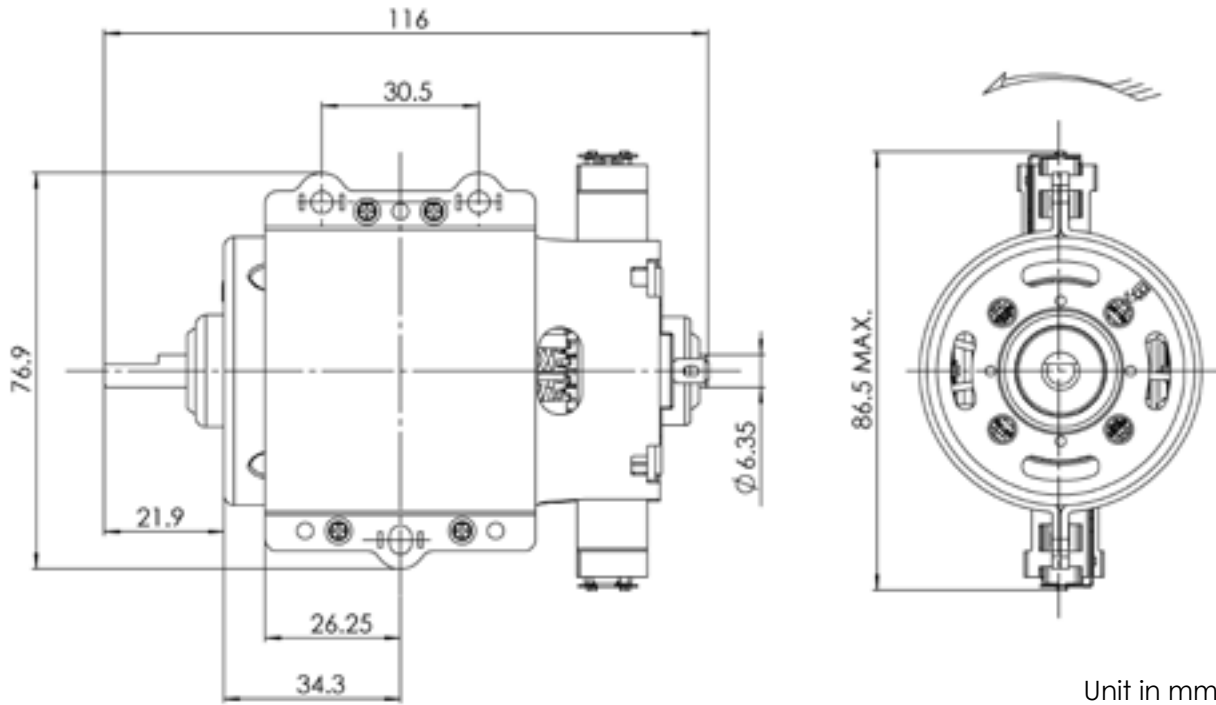

Unit in mm

## Performance Data:

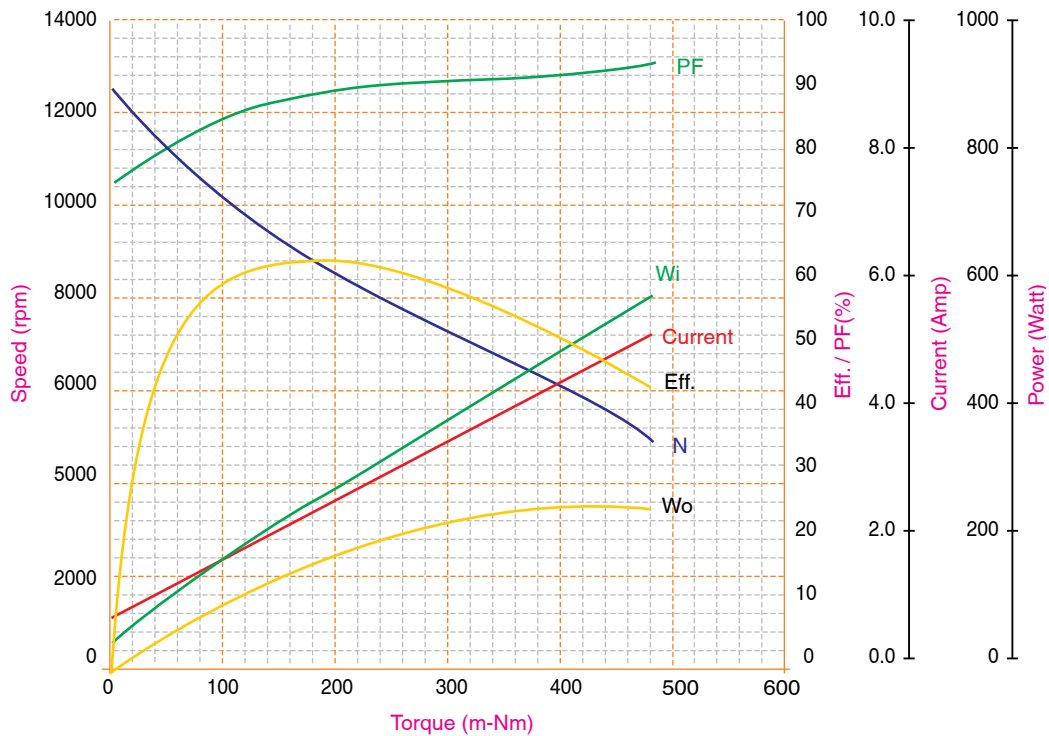

## Market

Home Appliances

## Application:

Stand Mixer



This high efficiency gearbox motor has a high torque specially designed for stand mixer application

## Motor Characteristics:

Diameter	: ~72 mm
Length	: 150 mm (without gearbox)
Flat	: 90 mm
Shaft Diameter	: 8 mm
Weight	: 2200 g (estimated with gearbox)
Nominal Voltage	: 120 V
Frequency	: 60 Hz
Pole Number	: 2

## Standard Data:

Operation Temperature	: -10 — 55°C
Storage Temperature	: -20 — 100°C
Mounting	: Any position
Electrical Connection	: Terminal
Winding Temperature (Tmax)	: 130 °C
Direction of Rotation	: CW
Approvals	: UL
Certifications	: E60303

## Electrical Performance:

	No Load	Max Eff
Speed (Rpm)	10014	7704
Current (A)	1.18	4.76
Torque (mNm)		374
Efficiency (%)		61.00
Output Power (W)		302.62



Drawing:

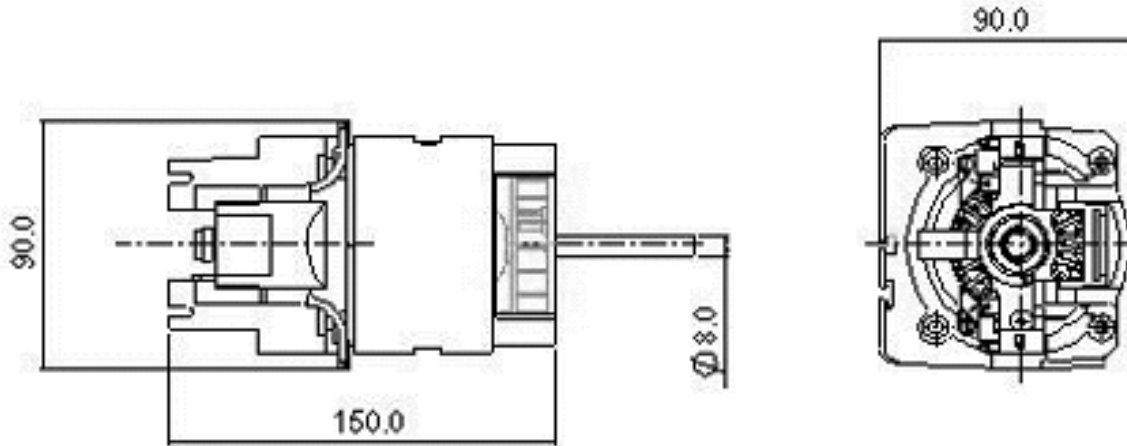

Unit in mm

Performance Data:

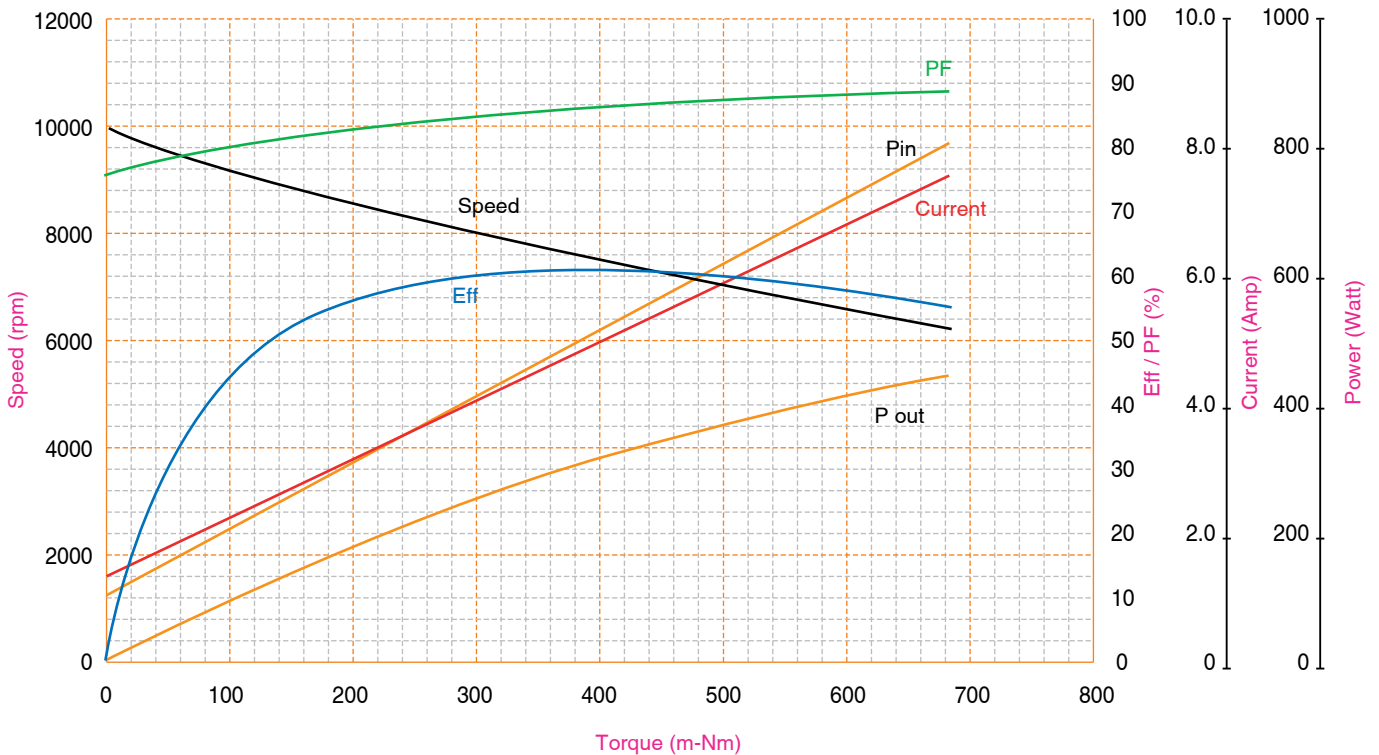

## Market

White Goods

## Application:

Dishwasher



This latest technology HVDC motor is used for dishwasher circulation pump

## Motor Characteristics:

Diameter	: ~ 72 mm
Length	: ~143.65 mm
Shaft Diameter	: 8 mm
Weight	: ~ 1.1 kg
Nominal Voltage	: 110-240 V
Frequency	: 50/60 Hz

## Standard Data:

Operation Temperature	: 10 — 40°C
Storage Temperature	: -20 — 70°C
Mounting	: Any position
Electrical Connection	: Terminal
Winding Temperature (Tmax)	: 220 °C
Direction of Rotation	: CCW
Standards	: CE / UL

## Electrical Performance:

	No Load	Max Eff	Max Power
Speed (Rpm)	3560	2996	1808
Current (A)	0.2	0.79	1.64
Torque (mNm)		166	512
Efficiency (%)		71.5	50.50
Output Power (W)		52	97

## Drawing:

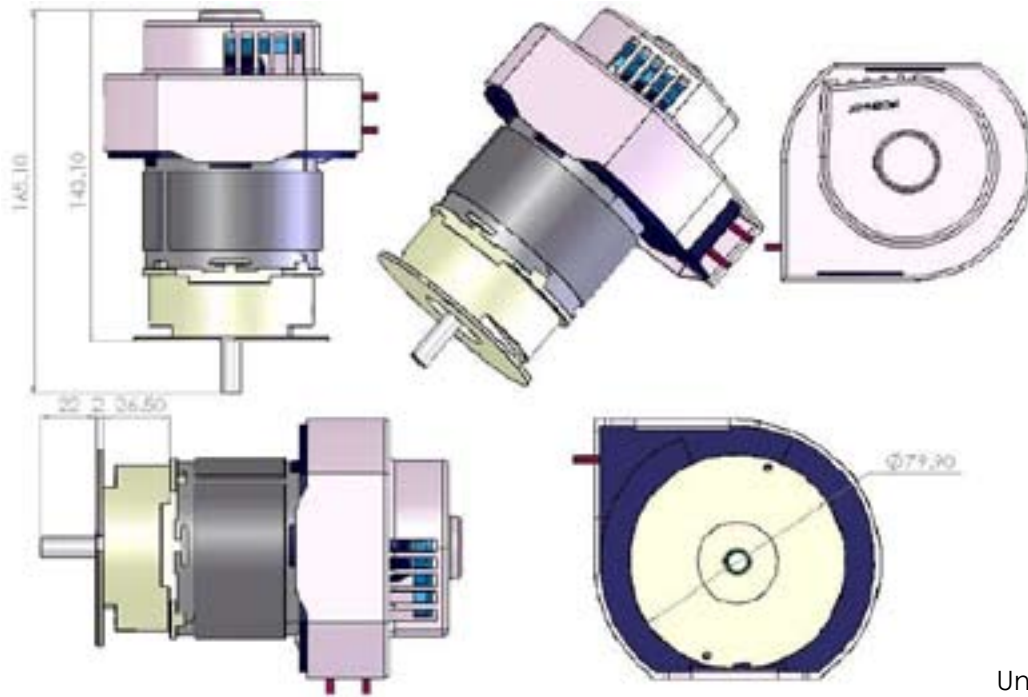

Unit in mm

HVDC

## Performance Data:

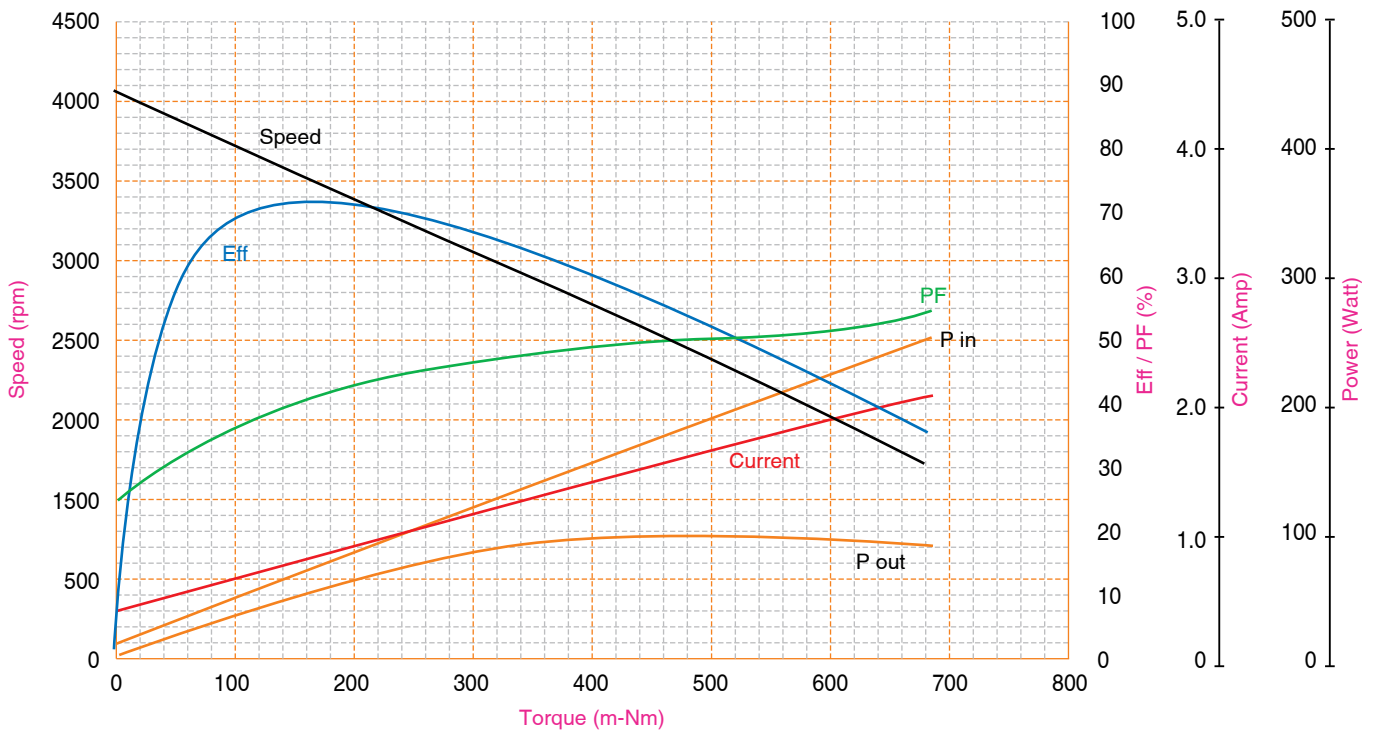

**Market**

Personal Care

**Application:**

Hair Clipper

**Motor Characteristics:**

Diameter	: 29 mm
Length	: 49 mm
Flat	: 25 mm
Shaft Diameter	: 2.3 mm
Weight	: 105 g
Nominal Voltage	: 240 V
Frequency	: 50 Hz
Pole Number	: 3

**Standard Data:**

Power Consumption	: 12 W
Power Output	: 5.5 W
Running Torque	: 10 cNm
Direction of Rotation	: CCW
Standards	: UL, CSA VDE
Remarks	: Protector

**Electrical Performance:**

	No Load	Max Eff	Max Power
Speed (Rpm)	7200	5625	3653
Current (A)	0.02	0.07	0.13
Torque (mNm)		13	28.8
Efficiency (%)		49	38
Output Power (W)		7.6	11

## Drawing:

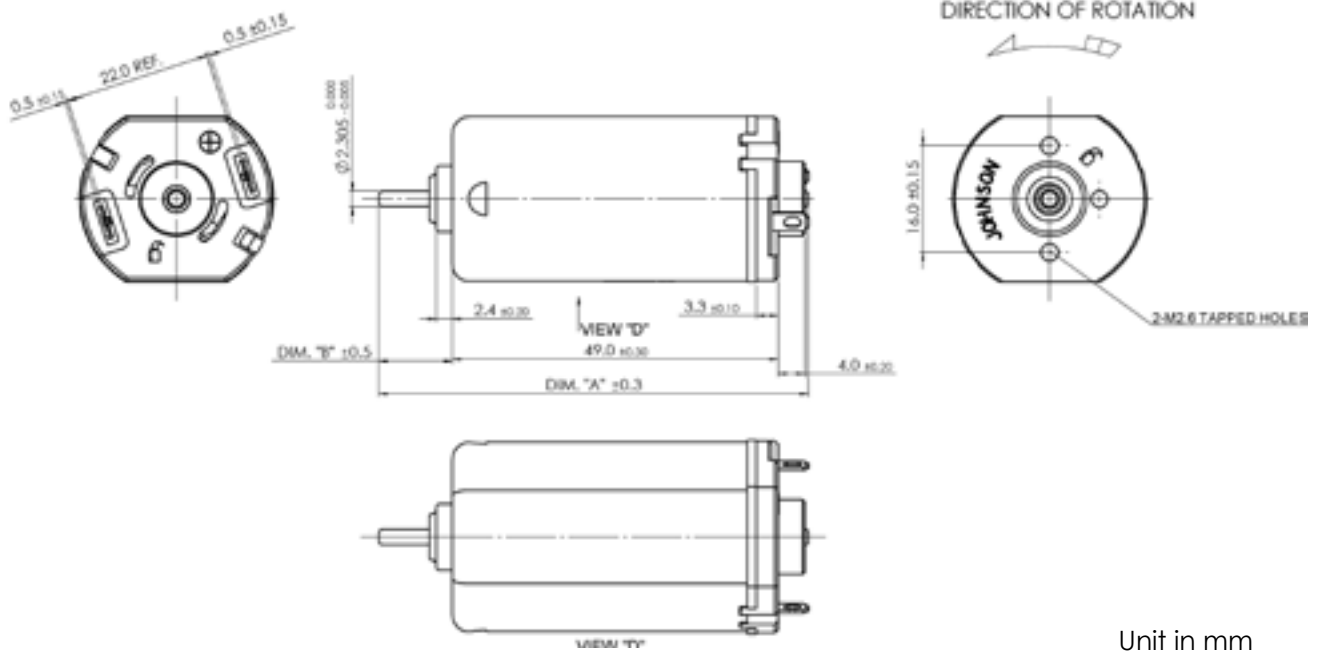

## Performance Data:

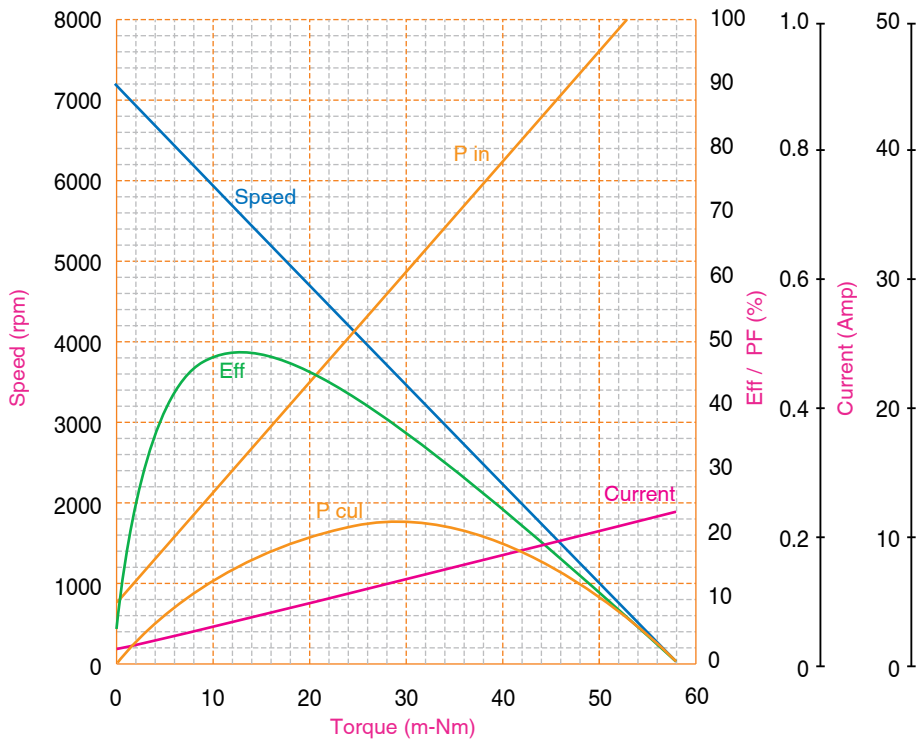

## Market

Personal Care

## Application:

Hair Clipper



Compact powerful high voltage DC motor

## Motor Characteristics:

Diameter	: 28.9 mm
Length	: 49 mm
Flat	: 24.7 mm
Shaft Diameter	: 2.305 mm
Weight	: 105 g
Nominal Voltage	: 120 V
Frequency	: 60 Hz
Pole Number	: 5

## Standard Data:

Power Consumption	: 11 W
Power Output	: 4.3 W
Running Torque	: 10 m-Nm
Direction of Rotation	: CCW
Standards	: UL, E60303

## Electrical Performance:

	No Load	Rated Load	Max Eff	Max Power
Speed (Rpm)	5500	4000	4000	2700
Current (A)	0.02	0.07	0.07	0.12
Torque (mNm)		10	10	19.42
Efficiency (%)			45	
Input Power (W)		11	11	
output Power (W)		4.3		5.575

## Drawing:

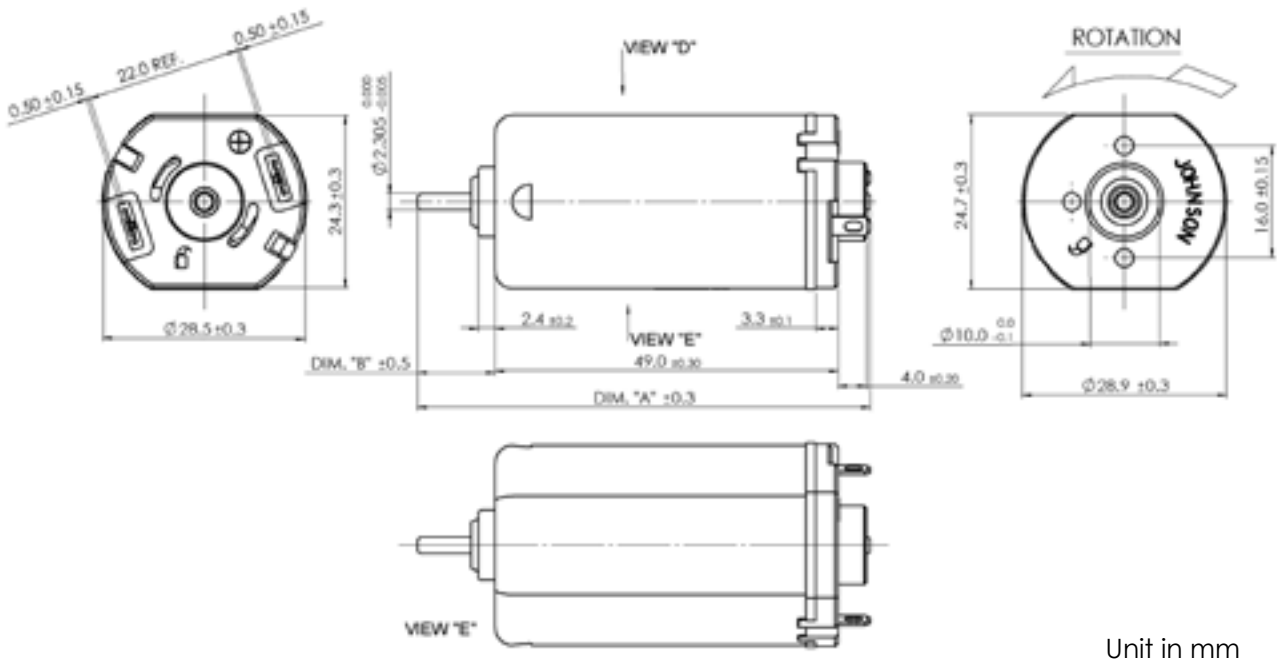

## Performance Data:

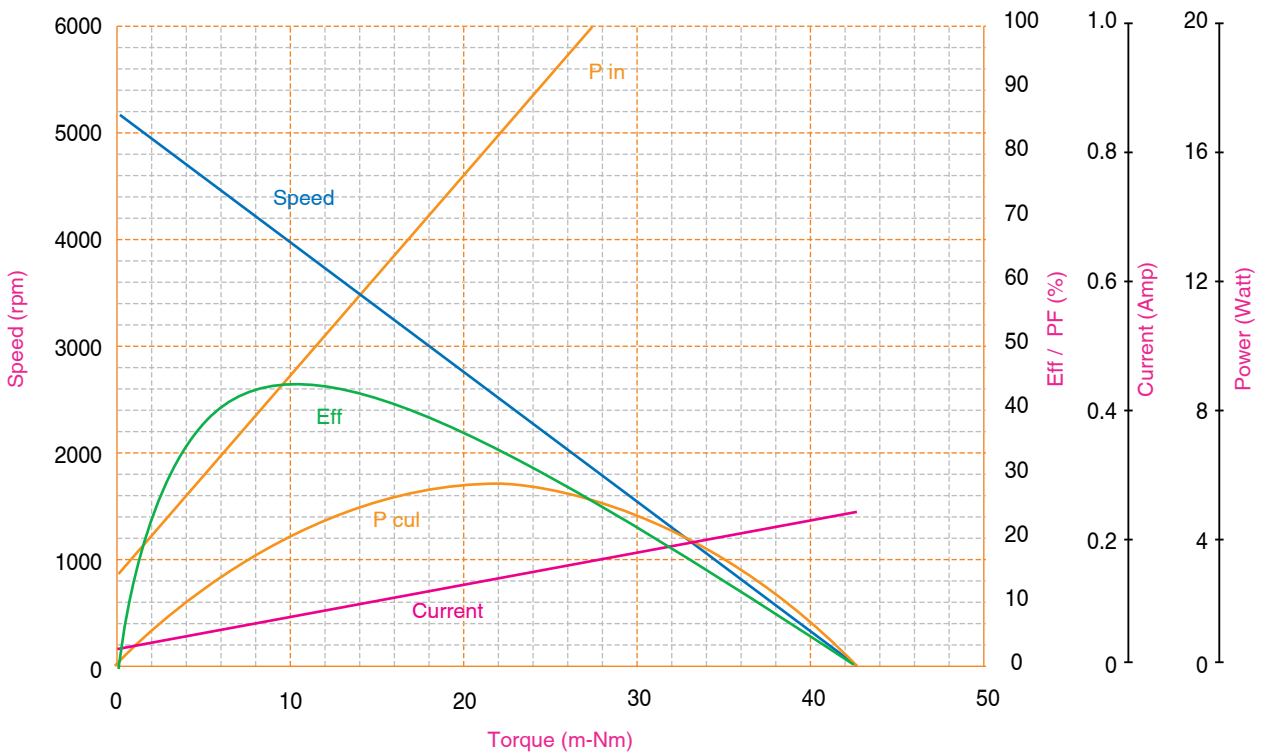

## Market

Floor Care

## Application:

Power Brush



This motor is for low power application at 120 V

## Motor Characteristics:

Diameter	: 38.5 mm
Length	: 63.0 mm
Flat	: 32 mm
Shaft Diameter	: 4 mm
Weight	: 221 g
Nominal Voltage	: 120 V
Frequency	: 60 Hz
Pole Number	: 2

## Standard Data:

Operation Temperature	: -10 — 55°C
Storage Temperature	: -20 — 100°C
Mounting	: Any position
Electrical Connection	: Terminal
Winding Temperature (Tmax)	: 130 °C
Direction of Rotation	: CW
Approvals	: UL
Certifications	: E60303

## Electrical Performance:

	No Load	Max Eff	Max Power
Speed (Rpm)	9739	7791	4870
Current (A)	0.09	0.38	0.81
Torque (mNm)		35.28	88.2
Efficiency (%)		62	45
Input Power (W)		46.40	98
output Power (W)		28.77	44.1



## Drawing:

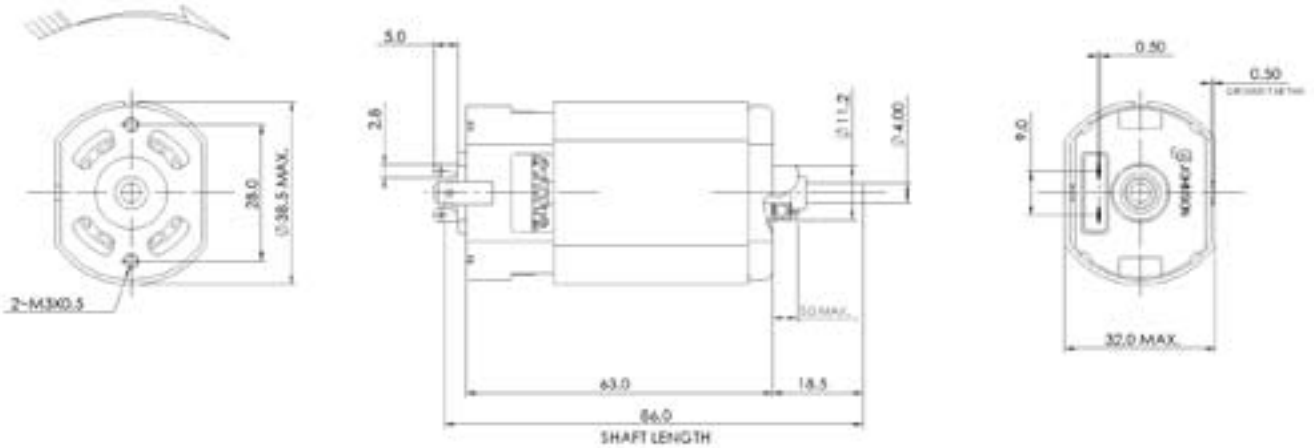

Unit in mm

## Performance Data:

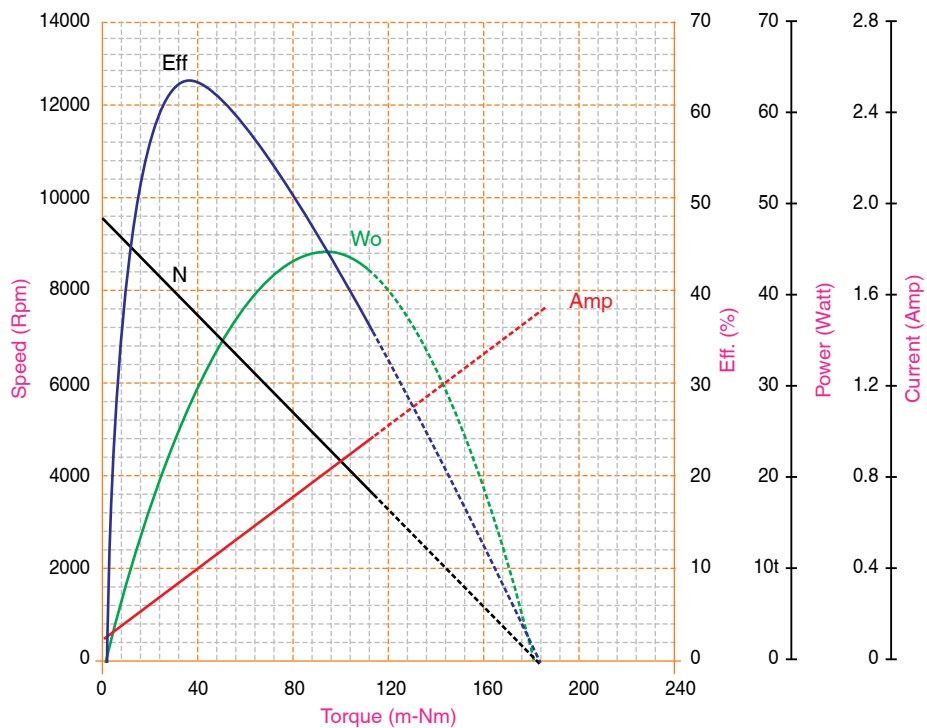

## Market

White Goods

## Application:

Ice Auger



This motor specially designed for ice auger application in refrigerator

## Motor Characteristics:

Diameter	: 42.5 mm
Length	: 63 mm
Flat	: 32 mm
Shaft Diameter	: 4 mm
Weight	: 223 g
Nominal Voltage	: 100 V
Frequency	: 60 Hz

## Standard Data:

Operation Temperature	: -10 — 55°C
Storage Temperature	: -20 — 80°C
Mounting	: Any position
Electrical Connection	: Terminal
Winding Temperature (Tmax)	: 130 °C
Direction of Rotation	: CCW

## Electrical Performance:

	No Load	Stall	Max Eff	Max Power
Speed (Rpm)	13575		9603	6001
Current (A)	0.13	7.85	0.47	0.95
Torque (mNm)		130	30.71	77.26
Efficiency (%)			59.2	44.28
Output Power (W)			30.85	48.27

## Drawing:

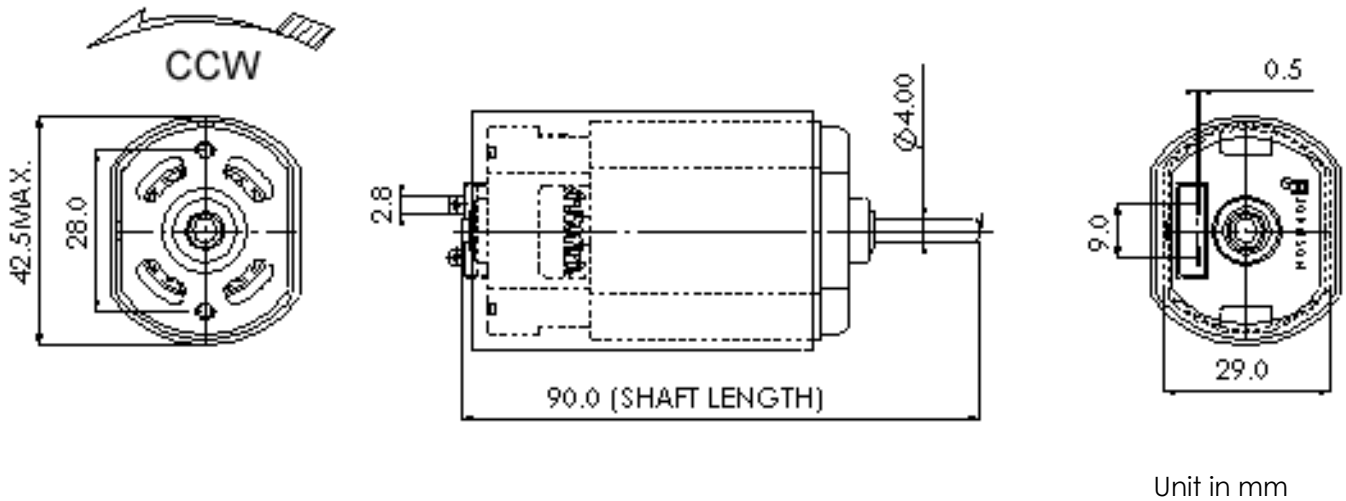

## Performance Data:

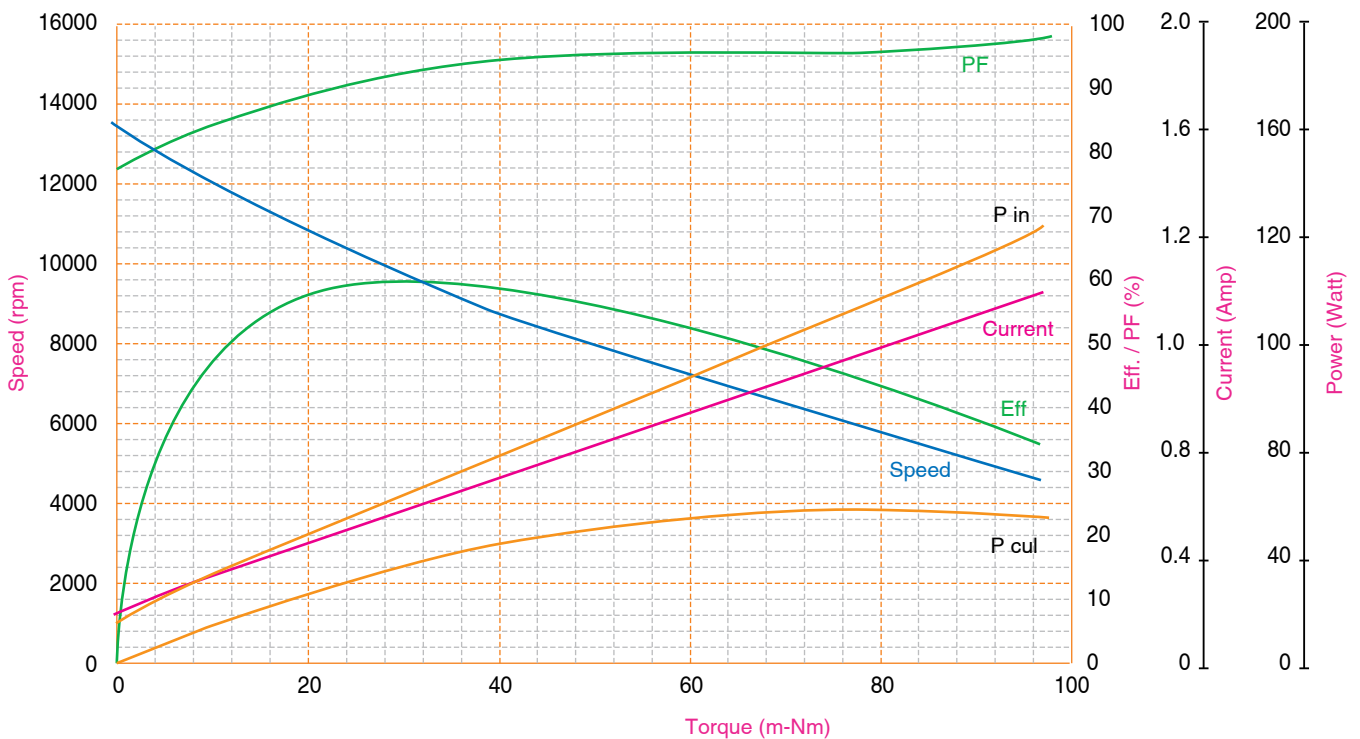

## Market

Floor Care

## Application:

Power Brush



This motor is for low power application at 230 V

## Motor Characteristics:

Diameter	: 38.5 mm
Length	: 63 mm
Flat	: 32 mm
Shaft Diameter	: 4 mm
Weight	: 218.7 g
Nominal Voltage	: 230 V
Frequency	: 50 Hz

## Standard Data:

Operation Temperature	: -10 — 55°C
Storage Temperature	: -20 — 100°C
Mounting	: Any position
Electrical Connection	: Terminal
Winding Temperature (Tmax)	: 130 °C
Direction of Rotation	: CCW

## Electrical Performance:

	No Load	Rated Load	Max Eff	Max Power
Speed (Rpm)	12731	9100	8800	6200
Current (A)	0.076	0.25	0.28	0.44
Torque (mNm)		37.82	40	70
Efficiency (%)			60.3	
Input Power (W)		58	60.7	
Output Power (W)		36	36.65	44.7

## Drawing:

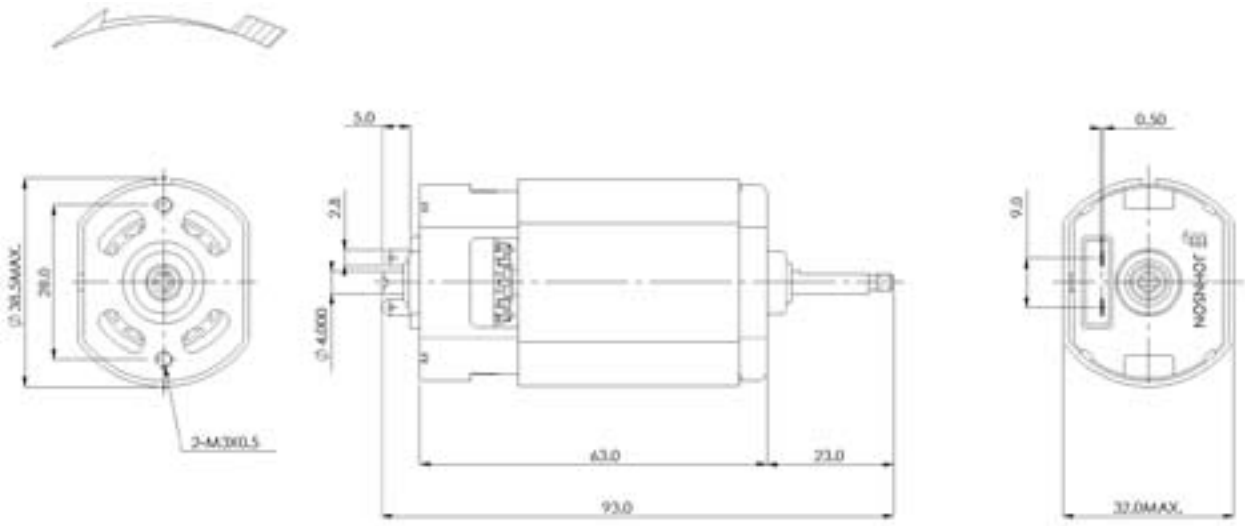

Unit in mm

## Performance Data:

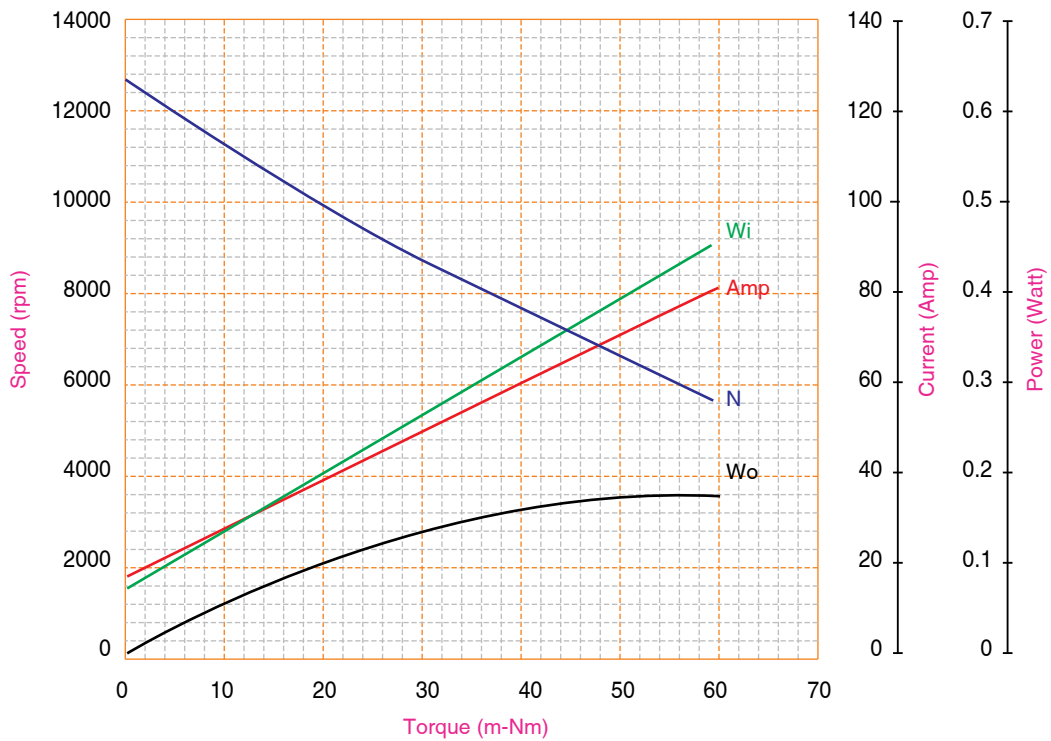

## Market

Floor Care

## Application:

Power Brush



This motor is for low power application with shaft pinion at 120 V

## Motor Characteristics:

Diameter	: 38.5 mm
Length	: 92 mm
Shaft Diameter	: 4.0 mm
Weight	: 225 g
Nominal Voltage	: 120 V
Frequency	: 60 Hz

## Standard Data:

Operation Temperature	: -10 — 55°C
Storage Temperature	: -20 — 100°C
Mounting	: Any position
Electrical Connection	: Terminal
Direction of Rotation	: CW
Standards	: UL, E60303

## Electrical Performance:

	No Load	Max Eff	Max Power
Speed (Rpm)	11751	8248	9600
Current (A)	0.09	0.44	0.3
Torque (mNm)		27.92	14
Efficiency (%)		50.71	48
Output Power (W)		24.35	14.5

## Drawing:

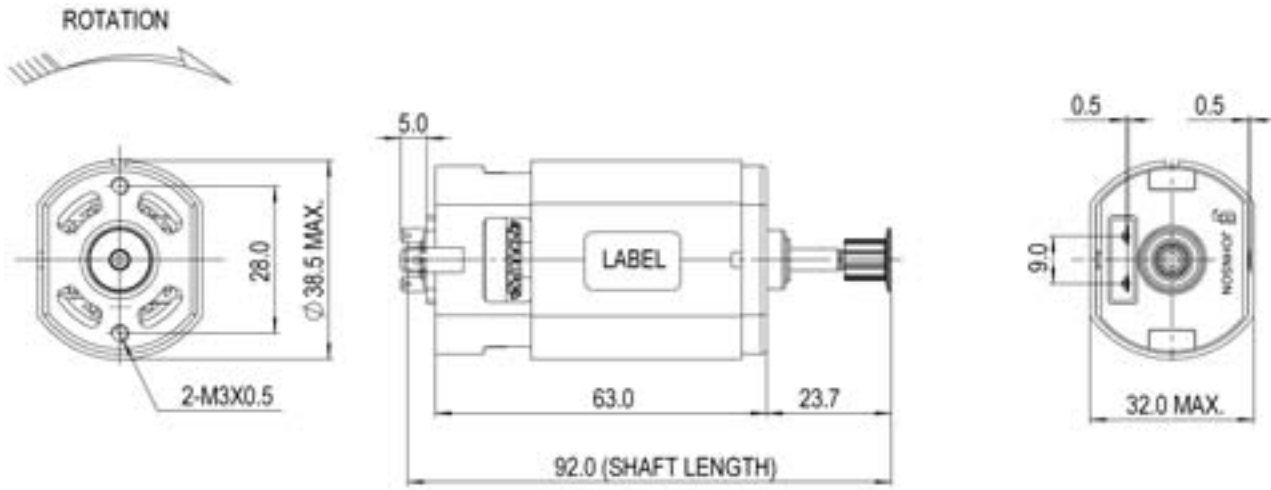

Unit in mm

## Performance Data:

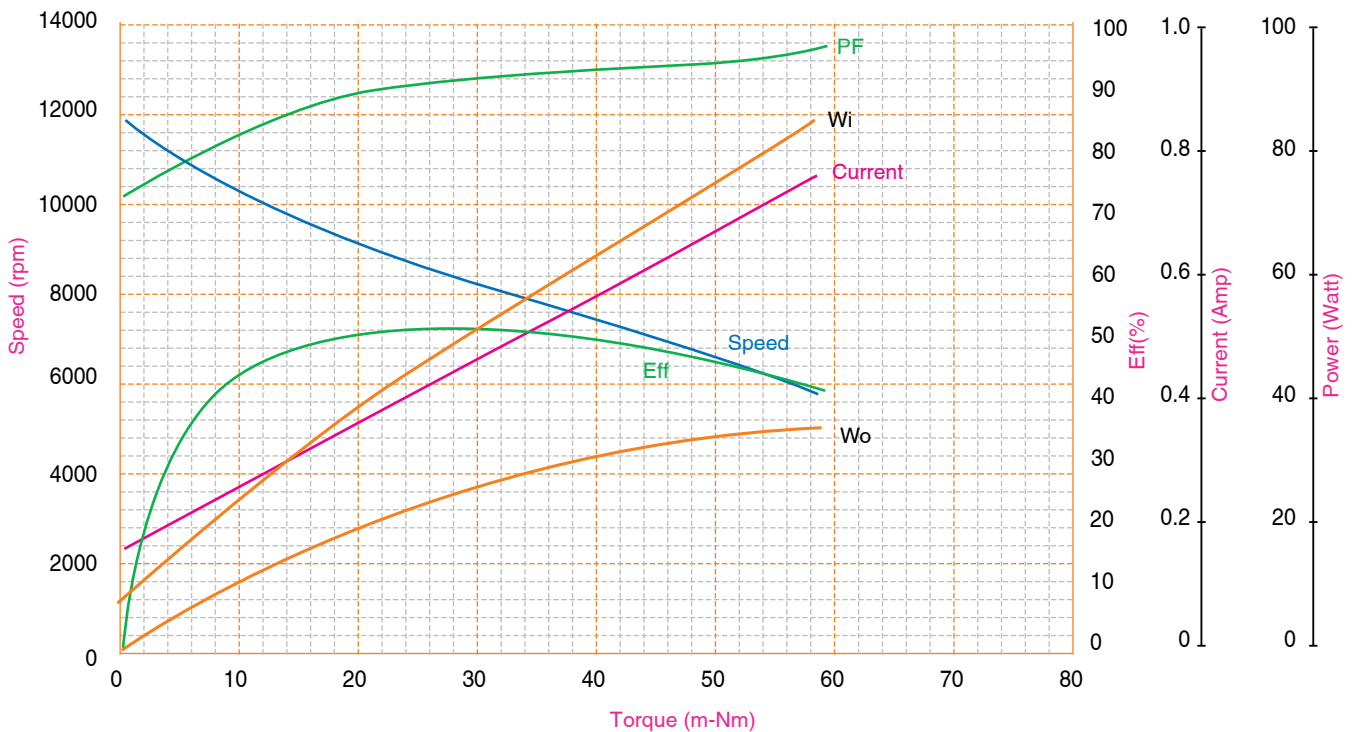

## Market

Power & Garden

## Application:

Rotary Tool



This HVDC #600 series motor is compact and powerful making it ideal for use in the compact rotary tool market

## Motor Characteristics:

Diameter	: 38.5 mm
Length	: 63 mm
Flat	: 32 mm
Shaft Diameter	: 4 mm
Weight	: 220 g
Nominal Voltage	: 120 V
Frequency	: 60 Hz
Pole Number	: 12

## Standard Data:

Operation Temperature	: -10 — 50°C
Storage Temperature	: -20 — 100°C
Mounting	: Any position
Electrical Connection	: Terminal
Thermal Class	: UL Class A
Direction of Rotation	: CCW
Standards	: RoHS

## Electrical Performance:

	No Load	Rated Load	Max Eff	Max Power
Speed (Rpm)	13463	11900	9300	5900
Current (A)	0.14	0.2	0.52	0.99
Torque (mNm)		6.0	30.0	73.0
Efficiency (%)			50.9	
Input Power (W)		21.0	57.0	
Output Power (W)		9.0		44.5



## Drawing:

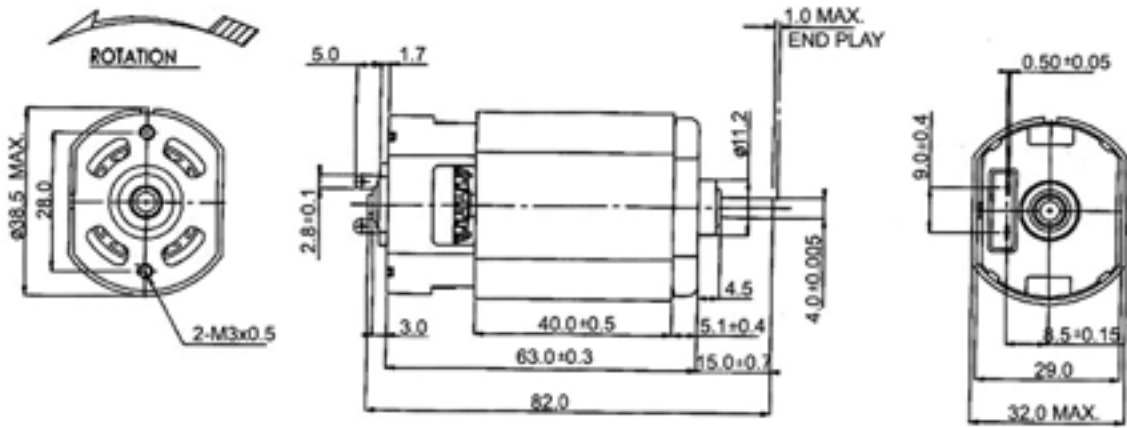

Unit in mm

## Performance Data:

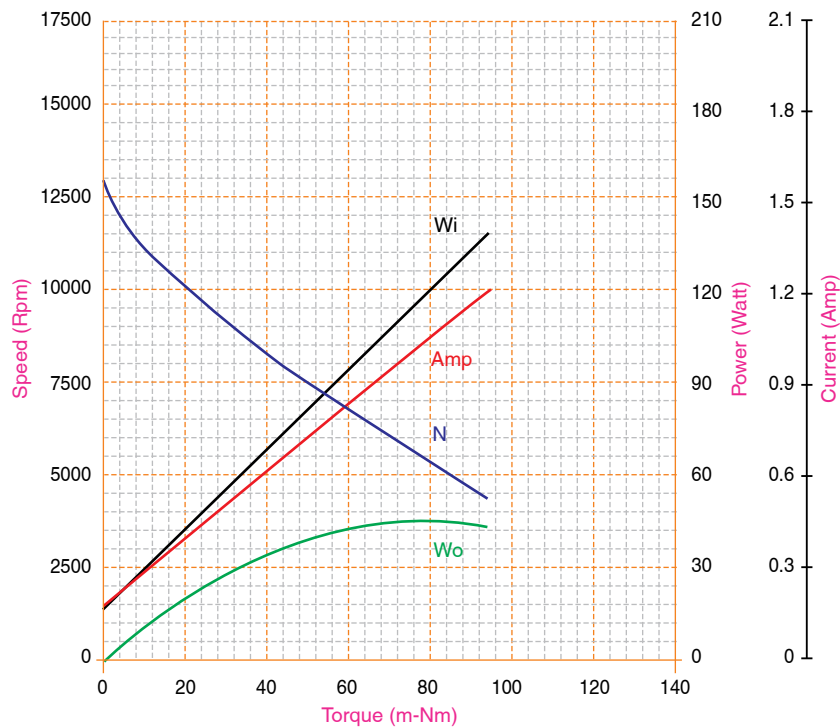



## Resource Informa-

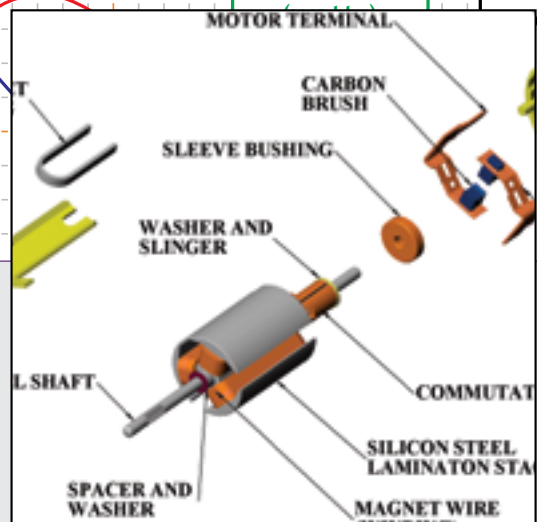
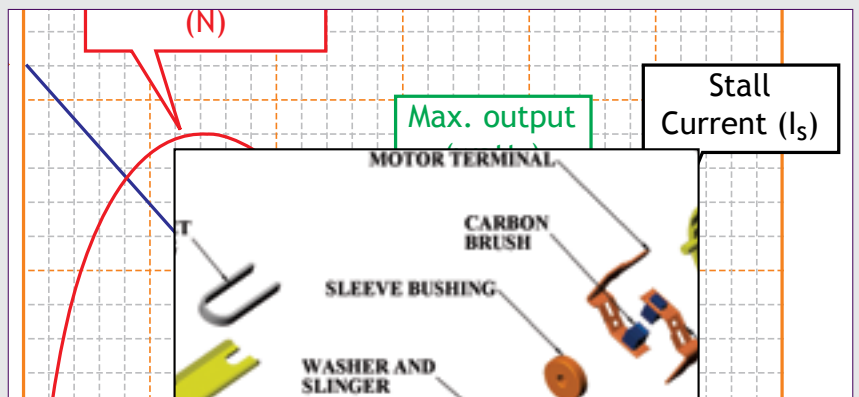

# Motor Basics

The function of the motor is to convert electrical energy to mechanical energy. Thus, the motor is also classified as an electromechanical device/machine

## Motor Construction

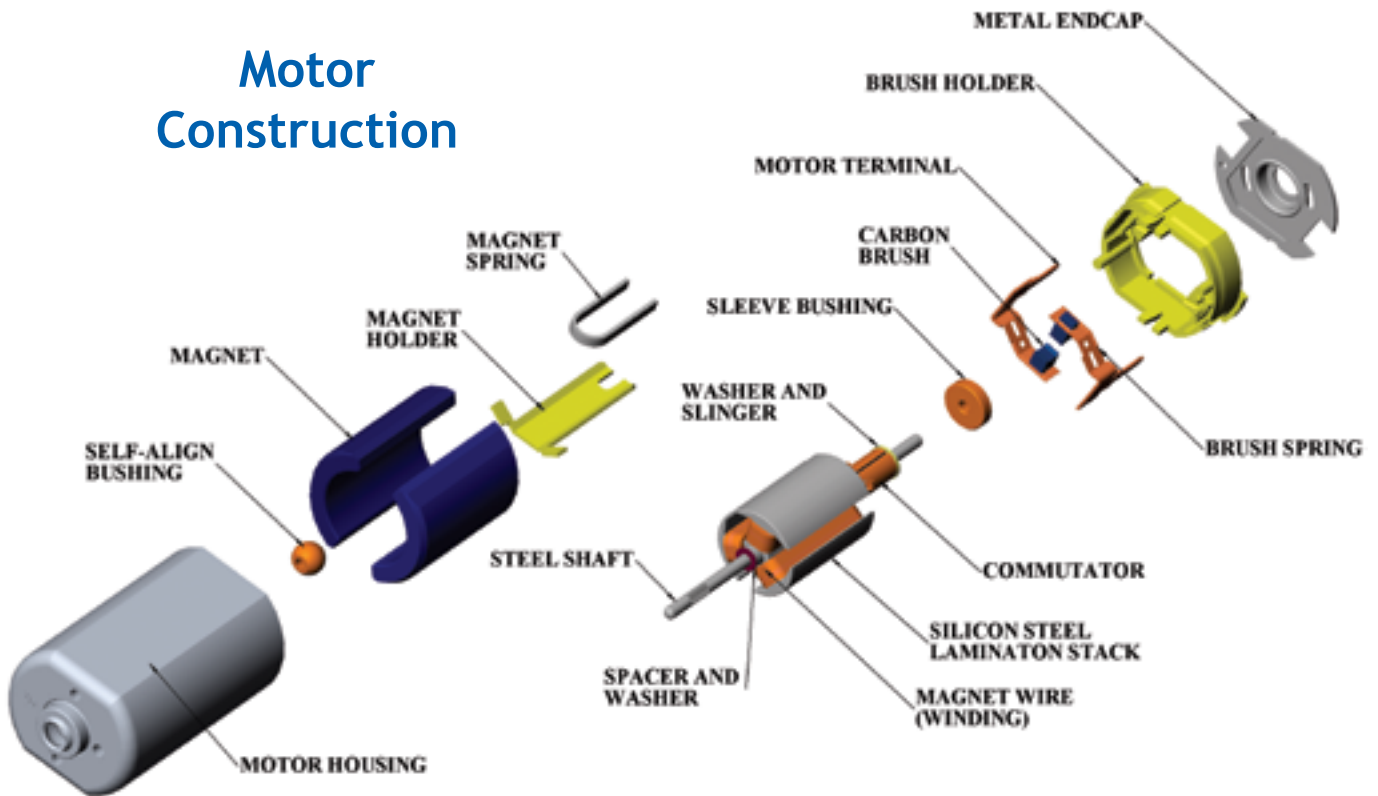

### Operation

Typically, electric motors run by electromagnetism. However, there are also other types of motors that utilize electrostatic forces or piezoelectric effect. In the case of a PMDC motor, motion is produced by an electromagnet (armature) interacting with a fixed field magnet (housing assembly).

Electrical current flows through the motor terminals in the endcap assembly that comes in contact with the commutator in the armature assembly through the carbon brushes or brush leaves. The electrical current powers the coils generating a magnetic field causing the armature to rotate as it interacts with the magnets encased in the housing assembly.

Flemming's Left Hand Rule helps to determine the direction of the force, the current and the magnetic flux.

### 3 Key Elements Interacting to Produce Motion

- **Magnetic Flux** - The motor housing which contains the permanent magnets generate a magnetic field with the core or lamination stack forming a path.
- **Current** - When electricity is applied across the motor terminals, current flows through from one end of the terminal to the brush, commutator then to the windings, back to the commutator and brush and out through the other terminal.
- **Force** - The current that flows through the magnetic field then produces an electromagnetic force that causes the shaft to rotate. As conductor rotates to opposite pole, the commutator switches the direction of the current and continuously causes the shaft to rotate. This continuous switching of current produces the rotating force. This generated rotating force is called torque and this is usually measured at the shaft.

## Main Components of a PMDC Motor

### Motor Housing Assembly (stator)

- Metal Housing - A metal case to house the magnets and bearings and fix the endcap. It is also responsible for producing a magnetic field using the magnets to chart the flow of magnetic force.
- Bearing - This component supports the shaft that is part of the armature assembly and also provides lubrication for the shaft to turn with less friction.
- Magnet - The permanent magnet is the key component in producing a magnetic field which in turn produces torque or the turning force of the motor
- Spring Holder - This component fixes the magnet to the housing

### Armature Assembly (rotor)

- Commutator - The commutator commonly uses copper segments and more recently, graphite. This component comes in contact with the brush to allow current to flow through the armature and is responsible for the direction of the current to shift as it spins and slides in contact with the brushes.
- Lamination Stack - Composed of stamped sheet metal called laminations, the lamination stack has slots for the magnet wire windings where current can flow.
- Magnet Wire - Magnet wires are used as windings for the armature.
- Shaft - The shaft is where the mechanical output characteristics of the motor are measured such as speed and torque. The whole idea of the motor is to provide rotational motion to the shaft.

### Endcap Assembly

- Brush Holder - This component holds the brush in place and provides electrical insulation from the metal housing.
- Endcap - The endcap is a stamped metal part that holds the bearing in place and strengthens the plastic brush holder. The terminals protrude through the endcap.
- Terminals - Usually in pair, the terminals are the electrical input contacts of the motor.
- Brush - The brush, usually composed of carbon material, enables electrical current to flow from the terminal to the armature as it slides in contact with the commutator while the armature assembly is rotating.
- Brush Leaf - This component holds the brush and enables the brush to slide and come in contact with the commutator at just the right amount of pressure.

## Other Types of Motors:

What was described earlier was one type of Direct Current (DC) motor. There are several types of DC motors and Alternating Current (AC) motors, all utilizing electromagnetism to generate motion.

1. Wound Field DC Motor - Instead of using a fixed magnet on the stator as the PMDC motor has, this is replaced by electromagnets. There are 3 types of wound field DC motor
  - Series Wound - The field winding is in series with the armature winding. This produces a high torque low speed motor
  - Shunt Wound - The field winding is in parallel with the armature winding. This produces a low torque high speed motor
  - Compound Wound - The field winding is partly in parallel and partly in series. This produces a more balanced motor of a steady speed over a range of loads.

2. Stepper Motors - It is an electric motor without commutators. The commutator is replaced by an external motor controller that allows the shaft to be held in a fixed position or rotated in either direction in "steps". Typically, the construction of a stepper motor is that the windings of the motor are part of the stator and the rotor could be a permanent magnet or a magnetically soft material. Since this type of motor could be rotated to a specified position with more accuracy and ease, this is commonly used in applications that require high precision such as disk drives or camera autofocus lens



3. Brushless DC Motors (BLDC) - Like the stepper motor, the BLDC motor also does not have a commutator and brushleaf. Commutation (or switching) is produced through an external motor controller that is synchronized to the rotor's position. The rotor position is typically determined by the hall sensors and fed back to the motor controller. Utilizing the external motor controller, variable and precise speeds can be easily produced making it suitable for applications such as disk drive spindles or blower fans.

Though more expensive than a PMDC motor, the BLDC has an advantage of having longer life, higher efficiency and lower noise.





# Motor Basics

## 4. Universal Motors

- As the name implies, universal motors may use single phase AC or DC input current, but generally always used AC. Closely resembles a wound field DC motor, the mechanical force generated is uni-directional (one direction). The universal motor is designed for less than 1hp operation and can run up to 10,000 - 50,000 rpm speed at no-load condition. It is suitable for power tools and food mixer applications.



## Application Design Considerations:

Before selecting a motor for your application, consider your requirements first using below criteria as guide. Deciding on these factors will allow your technical support engineer to find the right motor for you.

- Size (form & fit) - allowable space to fit the motor
- Purpose / Application
- Output Requirements - constant or variable load, constant or variable speed, shaft/driving system (with gear, belt drive, impeller or fan, etc.), starting and stall conditions, clockwise or counter-clockwise rotation
- Power Source - AC, DC or other waveforms
- Environmental Condition - operating temperature, humidity, dusty/sandy/salty environment, vibration (such as installed in a moving vehicle), audible noise considerations, EMC, safety and other protections required, electrical noise
- Operating Conditions - continuous or intermittent, expected life of the application

5. Single Phase AC Synchronous Motors - Regardless of the load, this motor operates at a fixed synchronous speed directly proportional to the frequency of the input AC power. By energizing the electro-magnet in the stator, the rotor (containing a permanent magnet) will turn at a speed equivalent to the frequency. When the rotor turns it can turn in either direction. To avoid this, a mechanical device

called anti-return is placed on the rotor to ensure that the rotor will always turn on the same direction. The highly accurate speed, makes this motor suitable for tape drives or mechanical clock applications.



6. Shaded Pole Motors - Another type of AC single-phase induction motor, this motor has one main winding and start winding being called shade pole ring. Rotation is done using a copper ring around a small portion of each motor pole. The copper ring “shades” that portion of the pole, causing the magnetic field of the pole with the copper ring to lag the field of the pole without the copper ring. This interaction between the two magnetic fields enables rotation. Because of a low starting torque, this motor is an economical and reliable solution for fan applications



# Motor Range Characteristics

## Permanent Magnet Direct Current (PMDC)

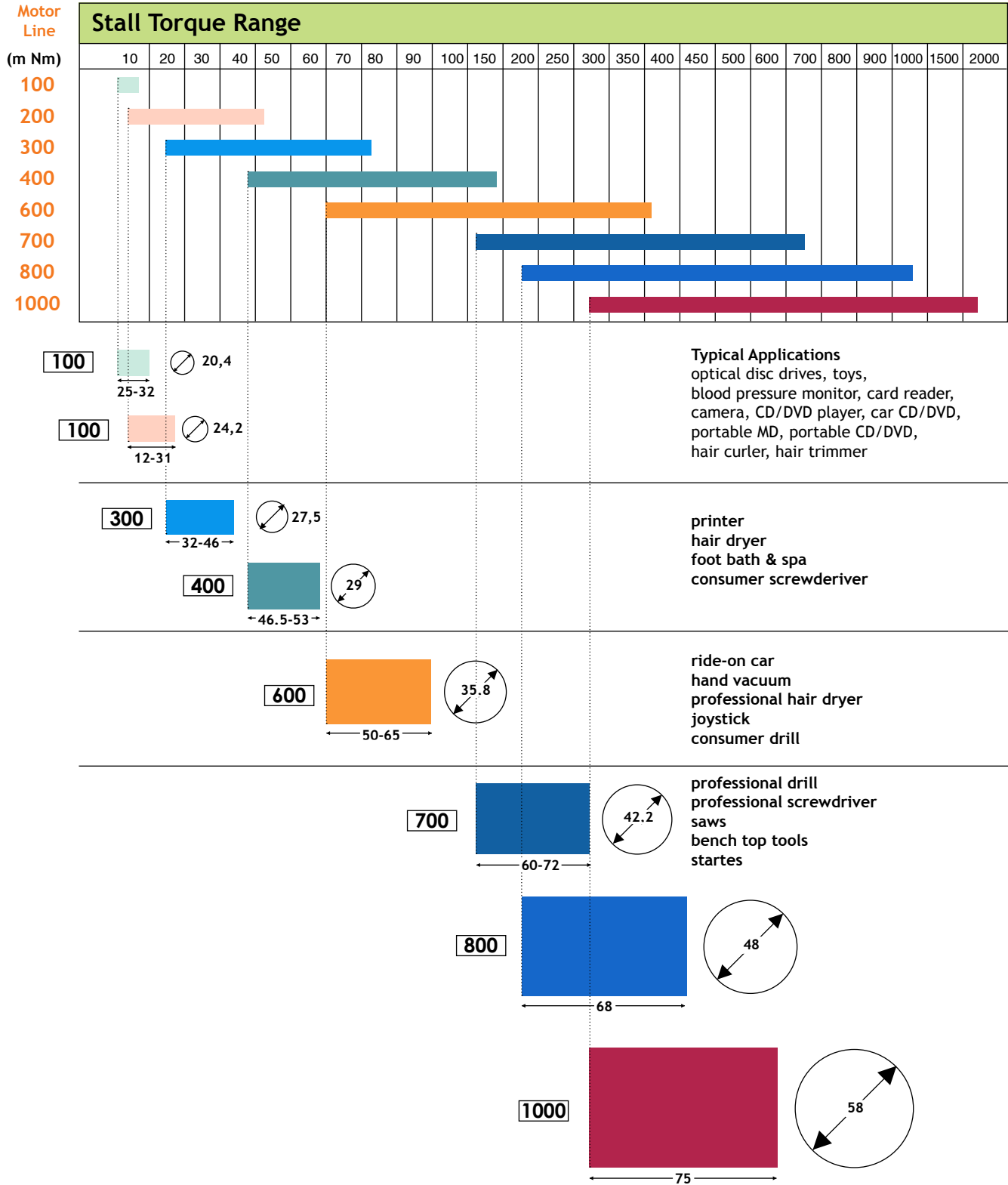

# Motor Range Characteristics

## High Voltage Direct Current

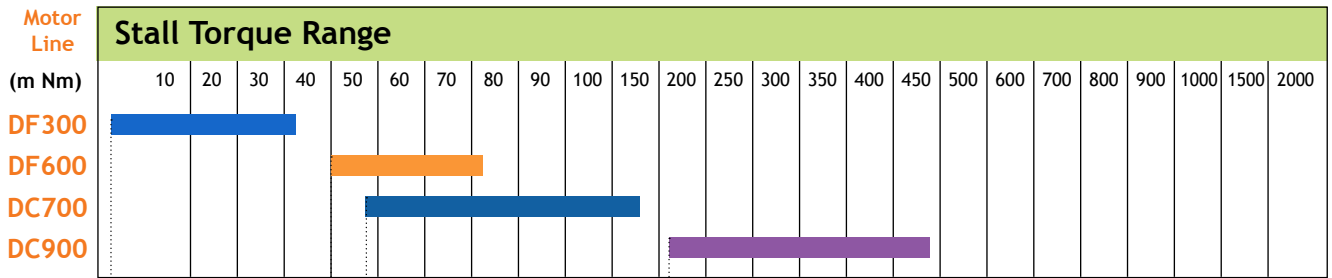

Typical Applications

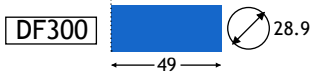

Hair Clipper

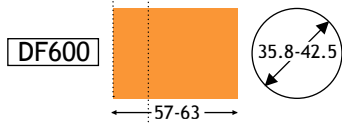

Sewing Machine  
Refrigerator

Brush Roll

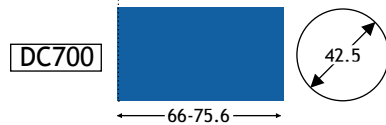

Coffee Grinder  
Stand Mixer  
Hedge Trimmer  
Dishwasher

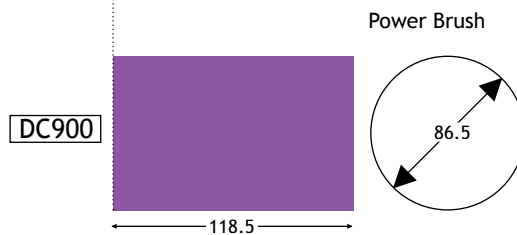

Power Brush

MOTOR BASICS



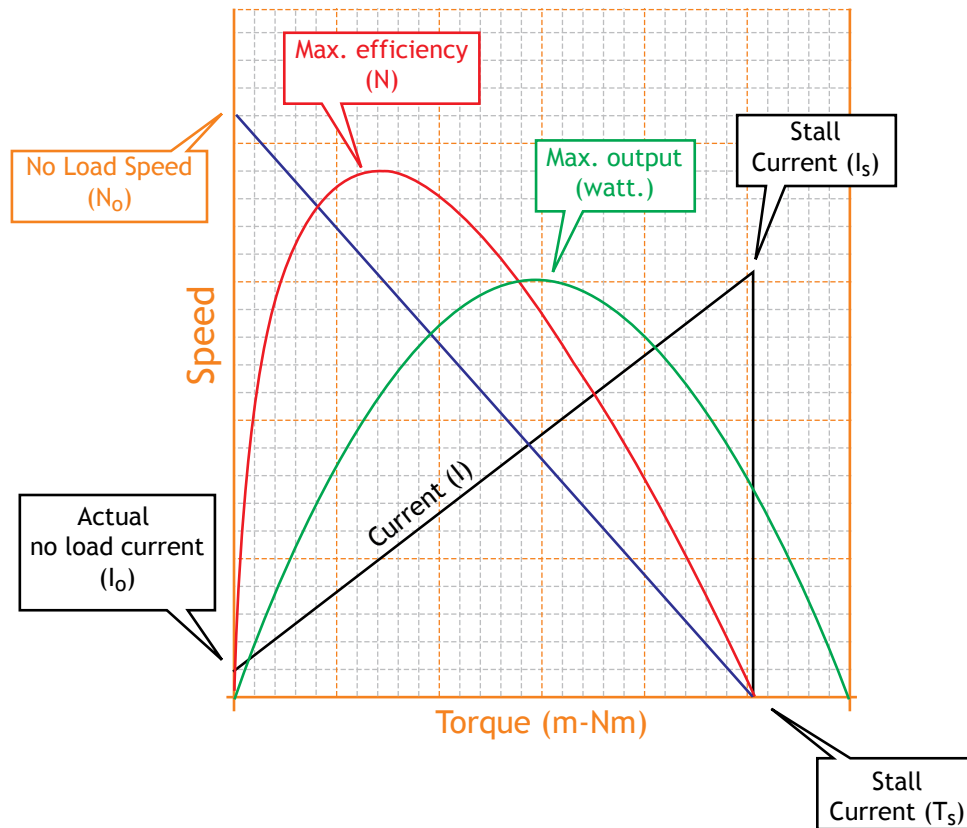

## Understanding the Performance Chart

There are 4 critical points in the performance chart.

- No Load Speed (N<sub>0</sub>) - This pertains to the speed of the shaft measured in number of revolutions per minute (rpm) when voltage is applied without any mechanical resistance or load on the motor.
- No Load Current (I<sub>0</sub>) - This pertains to the current measured during no load condition of the motor.
- Stall Torque (T<sub>S</sub>) - This pertains to the torque measured when the motor stops rotating due to the increase in load.
- Stall Current (I<sub>S</sub>) - This pertains to the current measured during stall condition of the motor due to the increase in load.

## Plotting the Performance Chart

- Speed Line - This is the line that connects the points N<sub>0</sub> and T<sub>S</sub>, this line identifies the motor's speed at various conditions
- Current Line - This is the line that connects the points I<sub>0</sub> and I<sub>S</sub>, this line identifies the motor's current discharge at various conditions.

- Output Curve - This curve displays the output power of the motor and can be graphed using the formula:  

$$P = (\text{Speed} \times \text{Torque}) / 9550$$
<where speed is in rpm and torque in mNm>
- Efficiency Curve - This curve displays the efficiency of the motor and can be graphed using the formula:  

$$\text{Eff} (\%) = ((\text{Output Power} / (\text{Voltage} \times \text{Current})) \times 100$$

## Main Factors Affecting Motor Performance

- Input Voltage - Increase in input voltage increases N<sub>0</sub>, I<sub>S</sub> and T<sub>S</sub> while I<sub>0</sub> remains unchanged.
- Series Resistance - Increase in series resistance will cause T<sub>S</sub>, I<sub>S</sub> to decrease, while I<sub>0</sub> and N<sub>0</sub> remain unchanged.
- Number of Winding Turns - Increase in number of winding turns will decrease N<sub>0</sub>, I<sub>0</sub> and I<sub>S</sub>, while T<sub>S</sub> is unchanged.
- Winding Wire Diameter - Increasing the diameter of the winding wire will increase T<sub>S</sub> and I<sub>S</sub>, while I<sub>0</sub> and N<sub>0</sub> remains unchanged.
- Magnetic Flux - Increasing the magnetic flux will decrease N<sub>0</sub> and I<sub>0</sub> and increase T<sub>S</sub> while I<sub>S</sub> will remain unchanged.
- Temperature - Increase in environmental temperature increases N<sub>0</sub> and I<sub>0</sub> while decreases I<sub>S</sub> and T<sub>S</sub>.

## Headquarters

Johnson Electric Holdings Limited  
Johnson Building, 6-22 Dai Shun St, Tai Po Industrial  
Estate, New Territories

### Hong Kong

Tel: +852 2663 6688

Fax: +852 2897 2054

e-mail: salessupport@johnsonelectric.com

## Sales Offices

### Asia

#### Shanghai, China

12/F, Hua Rong Tower  
1289 Pudong Road South

#### Shanghai

200122 China

T +86 21 5882 2880

F +86 21 5882 2800

#### Tokyo, Japan

Keihin Higashi-Ohi Bldg.  
10/F, 2-13-8 Higashi-Ohi  
Shinagawa-ku

Tokyo 140-0011 Japan

T +81 3 5762 1031

F +81 3 5762 1032

#### Seoul, Korea

Misung Bldg B127, 115-7  
Nonhyun-Dong, Kangnam-Gu,

Seoul, Korea 135-010

T +82 2 518 8347/8341

F +82 2 518 8342

#### Singapore

50 Raffles Place #24-02,  
Singapore Land Tower

Singapore 048623

T +65 6224 7570

F +65 6224 4538

### Europe

#### Austria

**Slovenia, Slovakia, Hungary,  
Czech Republic**

Linzer Bundesstrasse 101

A-5023 Salzburg

T +43 662 88 4910

F +43 662 88 4910 11

#### France

10 Bld. Louise Michel

F-92230 Gennevilliers

T +33 1 46 88 07 70

F +33 1 46 88 07 99

78 Boulevard du 11 Novembre

69003 Villeurbanne

T +33 4 37 48 84 60

F +33 4 72 43 90 11

#### Germany

**Sweden, Denmark,  
Norway, Finland**

Weissenpferd 9

D-58553 Halver

T +49 2353 911 0

F +49 2353 911 230

#### Italy

Via Cadamosto 3

I-20094 Corsico, Milano

T +39 02 4869 21

F +39 02 4860 0692

1, Via Vittime di Piazza Fontana

I-10024 Moncalieri

T +39 011 68 05 401

F +39 011 68 05 411

#### Switzerland

**Poland, Spain, Turkey, Portugal**

Bahnhofstrasse 18

CH-3280 Murten

T +41 26 672 71 11

F +41 26 670 19 83

#### The Netherlands/Belgium

Hanzeweg 12c

NL-2803 MC Gouda

T +31 1825 43 154

F +31 1825 43 151

#### United Kingdom/Ireland

Dukesway

Team Valley Trading Estate

Gateshead

Tyne & Wear NE11 0UB

United Kingdom

T +44 191 401 61 00

F +44 191 401 63 05

### Americas

#### Connecticut

10 Progress Drive, Shelton,  
CT 06484, USA

T +1 203 447 5362

F +1 203 447 5383

#### Illinois

3115 N. Wilke Road - Suite C

Arlington Heights,

IL 60004

T +1 847 368 2146

F +1 847 368 2152

#### Ohio

801 Scholz Drive

Vandalia, OH 45377

T +1 937 454 2345

F +1 937 898 8624

#### Ontario, Canada

70 Ironside Crescent Unit 7

Scarborough, Ontario

M1X 1G4 Canada

T +1 416 299 0852

F +1 416 299 6756

#### Sao Paulo, Brazil

Av. Papa Joao Paulo I - 1256

CEP 07170-350

Guarulhos Sao Paulo, Brazil

T (55) 11-643 156 00

F (55) 11-643 247 11

**Johnson Electric Group**

Johnson Building, 6-22 Dai Shun Street  
Tai Po Industrial Estate, N.T., Hong Kong

Tel: (852) 2663 6688

Fax: (852) 2663 6110

Web Site: [www.johnsonelectric.com](http://www.johnsonelectric.com)